

be in motion be in motion

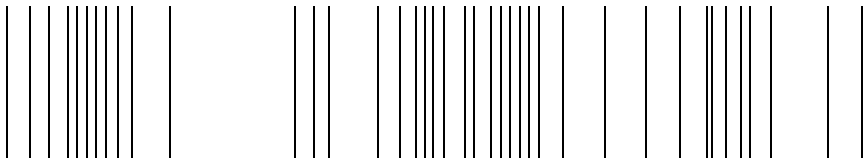

BUC64 S/A/F

**Feed / Feed back unit with
digital controller**

Manual

E	5.03054.01a
----------	-------------



BAUMÜLLER

Title	Manual
Product	Feed / Feed back unit with digital controller BUC64 S/A/F
Version	5.03054.01a
Status	2005-01-11
Copyright	<p>These operating instructions may be copied by the owner in any quantity but only for internal use. For other purposes these operating instructions and extracts thereof must not be copied or reproduced.</p> <p>Use and disclosure of information contained in these operating instructions are not permitted.</p> <p>Designations and company marks contained in these operating instructions may be brand names, the use of which by third parties for their own purposes may violate the rights of the holders.</p>
Obligatory	<p>These operating instructions are part of the equipment/machine. These operating instructions must be available to the operator at all times and must be in a legible condition. If the equipment/machine is sold or moved to a different location these operating instructions must be passed on by the owner together with the equipment/machine.</p> <p>After any sale of the equipment/machine this original and all copies must be handed over to the buyer. After disposal or any other end of use this original and all copies must be destroyed.</p> <p>When the present operating instructions are handed over, corresponding sets of operating instructions of a previous version are automatically invalidated. Please notice that specifications/data/information are current values according to the printing date. These statements are not legally binding according to the measurement, computation and calculations.</p> <p>Baumüller Nürnberg GmbH reserves the right, in developing its products further, to change the technical specifications and the handling of the products concerned without prior notice.</p> <p>No liability can be accepted concerning the correctness of the operating instructions unless otherwise specified in the General Conditions of Sale and Delivery.</p>
Manufacturer	Baumüller Nürnberg GmbH Ostendstr. 80 - 90 D-90482 Nürnberg Germany Tel. +49 9 11 54 32 - 0 Fax: +49 9 11 54 32 - 1 30 www.baumueller.de



Table of contents

1	Introduction	7
1.1	First steps	7
1.2	Terms used	7
1.3	Duties and liabilities	7
1.3.1	Paying attention to and observing the indications of danger and safety instructions	7
1.3.2	Danger while handling this appliance	8
1.3.3	Guarantee and Liability	8
2	Basic Safety Instructions	11
2.1	Hazard information and commands	11
2.1.1	Hazard information structure	12
2.1.2	Form of the hazard sign (triangular or round)	12
2.1.2.1	Hazard information on personal injury	13
2.1.2.2	Hazard information on property damage	18
2.1.2.3	Command signs used	18
2.2	Information sign	19
2.3	Appropriate use	19
2.4	Inappropriate use	19
2.5	Structural changes in the appliance	20
2.6	Disposal of the appliance	20
2.7	Fire fighting	21
3	Packing and Transportation	23
3.1	Transportation	23
3.2	Unpacking	23
3.3	Disposal of the packing	24
3.4	Points to be observed during transportation	24
4	Description of the Appliance	25
4.1	Charging circuit for the DC link circuit	25
4.2	Variants	26
4.3	General overall view with hazard areas	27
4.4	Identification markings on the appliance - type key	28
4.5	Block circuit diagrams	29
4.6	Construction drawing	31
4.7	Suggestion for controlling Power On/Off	33
5	Mounting	35
5.1	Hazard areas during mounting	35
5.2	Sequence of mounting	36
5.2.1	Selection of the control cabinet	36
5.2.1.1	Installation space - dimensioned diagrams	37
5.3	Drilling of holes/cutting threads and the recess	38
5.4	Mounting the appliance	39
5.4.1	Mounting the BUC64S	39
5.4.2	BUC64 mounting the through plugging variant A/F	41
5.4.2.1	Cooling medium	42
5.4.2.2	Connecting the cooling medium - circuit	44



Table of contents

6	Installation	45
6.1	General indications of hazards	45
6.1.1	Voltage test	46
6.2	Hazard from areas during installation	47
6.3	Requirements of the cables	47
6.4	Terminals	48
6.4.1	Power terminals	48
6.4.2	Control terminals	49
6.4.2.1	Control terminal X99A	50
6.4.2.2	Control terminal X98	51
6.4.2.3	Discharge circuit - terminal X1	52
6.5	Requirements for laying the cables (EMC instructions)	53
6.5.1	EMC regulation (EMVG)	53
6.5.2	Measures for compliance with the EMC	53
6.5.2.1	Cables	53
6.5.2.2	Earthing	56
6.5.2.3	Shielding	57
6.5.2.4	Leakage currents	58
6.6	Connection diagram	59
7	Commissioning	63
7.1	Requirements to the executing personnel	63
7.2	Check mounting	64
7.3	Checking the installation	64
7.4	Checking of the safety appliances	65
7.5	Switch on the device	65
7.5.1	Starting sequence	66
8	Operation	67
8.1	Safety instructions	67
8.2	Switching on	67
8.3	Monitoring functions and „ready for operation“	68
8.4	Monitoring functions	69
8.4.1	Monitoring functions, power unit	69
8.4.2	Monitoring functions of the controller	70
8.5	Ready for operation	71
8.6	Discharging of the DC link circuit/ballast control	71
9	Maintenance	73
9.1	Service intervals	73
10	Repair	75
11	Shutdown, Storage	77
11.1	Requirements of the personnel carrying out the shutdown	77
11.2	Safety instructions	77
11.3	Shutdown	78
11.4	Dismantling	78
11.5	Storage conditions	78
11.6	Maintenance during storage	78
11.7	Recommissioning	78
12	Disposal	79
12.1	Safety instructions	79
12.2	Requirements of the personnel entrusted with carrying the disposal	79
12.3	Disposal instructions	80



12.3.1	Subassemblies	80
12.4	Disposal agencies/authorities	81
Appendix A - Abbreviations		83
Appendix B - Accessories		85
B.1	EMC-accessories	85
B.2	Plug	86
B.2.1	Semiconductor fuses (F3, ▶ Figure 4 ◀ on page 29)	86
B.3	Mains-chokes	87
B.4	Water cooling	87
Appendix C - Declaration of Conformity/Manufacturer		89
C.1	What is an EU directive?	89
C.2	What the CE symbol indicates	89
C.3	Definition of the term Declaration of Conformity	90
C.4	Definition of the term Declaration by Manufacturer	90
C.5	Declaration of Conformity	91
C.6	Declaration by Manufacturer	92
Appendix D - Technical Data		93
D.1	Requirements of the power supply	93
D.2	Immunity level of burst	93
D.3	Required ambient conditions	94
D.4	Power unit - electrical data	96
D.5	Electrical data - chopper resistor	98
D.6	BUC64S - nonelectrical data	98
D.7	BUC64A - nonelectrical data	98
D.8	BUC64F - nonelectrical data	98
D.9	Cable : control voltage supply/ signals	99
D.10	Cable : power connection	99
Table of figures		101
Index		103



Table of contents

1

INTRODUCTION

The first steps that the user is required to take on receipt of the appliance are described in this Chapter. The terms used throughout this documentation has also been defined and information about the duties and obligations to be fulfilled while using this device given.

1.1 First steps

- 1 Check the consignment delivered, see [►Packing and Transportation◄](#) from page 23 onwards.
- 2 Pass on all the documents to the concerned sections.
- 3 Keep the suitable personnel for assembly and commissioning ready.
- 4 Hand over this Operation Manual to the personnel and make sure that especially the safety instructions given here are understood correctly and being followed.

1.2 Terms used

The term “appliance” is also used in this document for the Baumüller-Product „Feed / Feedback Unit with Digital Controller“. See [►Appendix A - Abbreviations◄](#) from page 83 - onwards for the abbreviations used.

1.3 Duties and liabilities

The user must know and observe the indications of danger and safety instructions given in this document in order to be able to handle and work with this appliance safely.

1.3.1 Paying attention to and observing the indications of danger and safety instructions

Optically uniform safety instructions (in the form of signs) are used in this Operation Manual, which should be protected to be free from any damage to property and injury to the personnel.



WARNING

The following **may occur**, if you do not observe this warning information:

- serious personal injury
- death

All the persons handling and working with this appliance must know and observe the indications of danger and safety instructions given in this Operation Manual

Furthermore, all the persons working with this appliance must know and observe in addition, all the rules & regulations applicable at the place of its employment.

1.3.2 Danger while handling this appliance

The appliance „Feed / Feedback Unit with Digital Controller“ has been developed and manufactured state of art and in compliance with the Standards and Guidelines applicable. In spite of that, there is still a possibility of some danger while using the same. An Overview of such likely dangers can be found in the Chapter [►Basic Safety Instructions◄](#) from page 11 onwards.

Furthermore, the user will be warned of the acute danger at the appropriate place.

1.3.3 Guarantee and Liability

These are governed basically by the “General terms of sale and supply” of Baumüller Nürnberg GmbH. These shall be available to you at the latest, from the date of conclusion of the contract. Guarantee and Liability claims of any kind cannot be raised against Baumüller Nürnberg GmbH, if, for instance the damage has been caused due to any of the causes listed below :

- you have disregarded the information given in this manual
- you have used this appliance within a non-appropriate application
- this appliance you have
 - unskillfully mounted
 - unskillfully connected
 - unskillfully commissioned
 - unskillfully operated
 - unskillfully or not maintained
 - let be mounted, connected, commissioned, operated and/or maintained by not or not adequate qualified personnel
 - overloaded
- operated it with
 - defective security devices
 - not properly mounted or without security devices
 - not efficient safety- and protection devices
 - environmental conditions being not within the specified values
- you have reconstructed this appliance without written permission of Baumüller Nürnberg GmbH.
- you have disregarded instructions concerning maintenance in the component manuals
- you have failed to monitor parts of wear and tear properly

- you have carried out a repair job unskillfully
- you have unskillfully combined the appliance with products of other manufacturers
- you have combined the drive system with defective and/or incorrectly documented products of other manufacturers

BASIC SAFETY INSTRUCTIONS

Every Baumüller plug-in module we have constructed and made according to strict safety specifications. Nevertheless the work with the plug-in module can be dangerous.

In this chapter we described hazards, that can arise when working with the Baumüller SIE module. Hazards we point up with symbols (icons). All the symbols that are used in this documentation are listed and explained.

How you can protect yourself against the single hazards in the concrete case, we will not explain in this chapter. In this chapter we will only give general safety precautions. We will go into concrete protective measures in subsequent chapters directly after information about the individual risk.

2.1 Hazard information and commands



Hazard information shows you the dangers, which can cause injuries or even your death.

Please always consider the hazard information which is given to you in this documentation.

Each hazard is classified in one of three different hazard classes. Every hazard class has one of the following characteristic signal words:

DANGER

- serious property damage
- serious personal injury
- death - **will** occur

WARNING

- serious property damage
- serious personal injury
- death - **may** occur

CAUTION

- minor to medium personal injury or
- environmental pollution or
- property damage - **may** occur

2.1 Hazard information and commands

2.1.1 Hazard information structure

The following two examples show you how the hazard informations are constructed. The triangle is used when indicating a hazard for human beings. When there is a circle instead of the triangle, the hazard information is only for possible property damage.

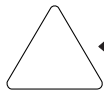

A triangle indicates hazard for human beings.
The shade of grey of the outline reflects the severity of the hazard - darker grey means rising hazard.

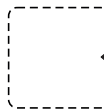

The icon within the square illustrates the hazard.
The outline's shade of grey reflects the severity of the hazard - darker grey means rising hazard. (Not every hazard information has a square representing the hazard, so we have shown it as draft here)



The icon in the circle represents a command.
(Not every hazard information has a circle representing the hazard, so we have shown it as draft here)



The circle indicates hazard for property.



The icon within the square illustrates the hazard.
The outline's shade of grey reflects the severity of the hazard - darker grey means rising hazard. (Not every hazard information has a square representing the hazard, so we have shown it as draft here)

The text beneath the icons is constructed as follows:

HERE STANDS THE SIGNAL WORD WHICH INDICATES THE DEGREE OF THE HAZARD



Here we tell if one or more of the consequences described lower will occur if this hazard information is not observed.

- here we describe the possible consequences. The worst consequence stands on the right side.

Here we describe the hazard.

Here we describe what you can do to avoid this hazard.

2.1.2 Form of the hazard sign (triangular or round)

If there is a triangle like  or  or  in front of the signal word, the hazard information is referring to personal damage.

If there is a round hazard signal like  in front of the signal word, the hazard information is referring to property damage.

2.1.2.1 Hazard information on personal injury

To distinguish each class of hazard information, we use a characteristic outline for both the triangular hazard signs and the square-form icons

For the hazard class **DANGER** we use the  danger sign. The hazard information of this hazard class we use in this documentation is listed below:

DANGER

The following **will occur**, if you do not observe this danger information:

- serious personal injury
- death

*The hazard is: **electricity**. Here the hazard may be described in detail.*

Here we describe what you can do to avoid the hazard.



DANGER

The following **will occur**, if you do not observe this danger information:

- serious personal injury
- death

*The hazard is: **mechanical influence**. Here the hazard may be described in detail.*

Here we describe what you can do to avoid the hazard.



2.1 Hazard information and commands

For the hazard class **WARNING** we use the warning sign . The following hazard information of this hazard class we will use in this documentation.



WARNING

The following **may occur**, if you do not observe this warning information:

- serious personal injury
- death

*The hazard is: **electricity**. Here the hazard may be described in detail.*

Here we describe what you can do to avoid the hazard.



WARNING

The following **may occur**, if you do not observe this warning information:

- serious personal injury
- death

*The hazard is: **mechanical influence**. Here the hazard may be described in detail.*

Here we describe what you can do to avoid the hazard.



WARNING

The following **may occur**, if you do not observe this warning information:

- serious personal injury
- death

*The hazard is: **electro-conductive liquid together with electricity**. Here the hazard may be described in detail.*

Here we describe what you can do to avoid the hazard.



WARNING

The following **may occur**, if you do not observe this warning information:

- serious personal injury
- death

*The hazard is: **electro-magnetic radiation**. Here the hazard may be described in detail.*

Here we describe what you can do to avoid the hazard.





WARNING

The following **may occur**, if you do not observe this warning information:

- serious personal injury
- death



*The hazard is: **liquid coolant**. Here the hazard may be described in detail.*

Here we describe what you can do to avoid the hazard.

2.1 Hazard information and commands

For the hazard class **CAUTION** we use the caution sign  when there is hazard for persons or of environmental pollution. The following hazard information of this hazard class we will use in this documentation.



CAUTION

The following **may occur**, if you do not observe this caution information:

- minor to medium personal injury.

*The hazard is: **hot surface**. Here the hazard may be described in detail.*

Here we describe what you can do to avoid the hazard.



CAUTION

The following **may occur**, if you do not observe this caution information:

- minor to medium personal injury.

*The hazard is: **sharp edges**. Here the hazard may be described in detail.*

Here we describe what you can do to avoid the hazard.



CAUTION

The following **may occur**, if you do not observe this caution information:

- minor to medium personal injury.

*The hazard is: **rotating parts**. Here the hazard may be described in detail.*

Here we describe what you can do to avoid the hazard.



CAUTION

The following **may occur**, if you do not observe this caution information:

- minor to medium personal injury.

*The hazard is: **injury of the eye caused by ricocheting particles**. Here the hazard may be described in detail.*

Here we describe what you can do to avoid the hazard.

**CAUTION**

The following **may occur**, if you do not observe this caution information:

- minor to medium personal injury.

*The hazard is: **noise**. Here the hazard may be described in detail.*

Here we describe what you can do to avoid the hazard.

**CAUTION**

The following **may occur**, if you do not observe this caution information:

- minor to medium personal injury.

*The hazard is: **hazard of sliding caused by liquid**. Here the hazard may be described in detail.*

Here we describe what you can do to avoid the hazard.

**CAUTION**

The following **may occur**, if you do not observe this danger information:

- environmental pollution.

*The hazard is: **unadequate disposal**. Here the hazard may be described in detail.*

Here we describe what you can do to avoid the hazard.



2.1 Hazard information and commands

2.1.2.2 Hazard information on property damage

If there is a round caution sign  in front of the signal word, the safety information refers to property damage.



CAUTION

The following **may occur**, if you do not observe this caution information:

- property damage.

*The hazard is: **electro-static discharge**. Here the hazard may be described in detail.*

Here we describe what you can do to avoid the hazard.



CAUTION

The following **may occur**, if you do not observe this caution information:

- property damage.

*The hazard is: **damage of the coolant hose**. Here the hazard may be described in detail.*

Here we describe what you can do to avoid the hazard.



2.1.2.3 Command signs used



carry safety gloves



carry safety shoes



carry eye protection



carry ear protection



Use this fire extinguishing agent:
ABC powder

2.2 Information sign



NOTE

This note is a very important information.

2.3 Appropriate use

You must always use this appliance properly. Listed below you will find some important information. The information given is intended to give you some impression on how to operate this appliance according to the terms. The information below is not a complete list; you must always observe the information given throughout this documentation.

- project this application in a way, that the appliance is run within its specifications.
- take care that only qualified personnel is working with or at this appliance.
- mount this appliance only at a reasonable steady wall.
- install this appliance according to the way shown in this documentation.
- take care that the power supply always meets the requested specifications.
- operate this appliance only if it is in a correct technical state.
- operate this appliance always in an environment according to the information given in the "Technical specifications".
- operate this appliance always in the regular condition.
For safety reasons you are not allowed to reconstruct this appliance.
- observe all respective information given if you want to store this appliance.

You are using this appliance according to the terms, if you observe all notes and information given in this operating manual.

2.4 Inappropriate use

Listed below you will find some examples of non-appropriate application. The information below is intended to give you some impression of what non-appropriate application is. However we cannot state all possible non-appropriate applications here. All applications, where the notes and information given in this documentation is disregarded, are non-appropriate and therefore forbidden.

Examples:

- you have disregarded the information given in this manual
- you have used this appliance within a non-appropriate application
- this appliance you have
 - unskillfully mounted
 - unskillfully connected
 - unskillfully commissioned
 - unskillfully operated
 - unskillfully or not maintained

2.5 Structural changes in the appliance

- let be mounted, connected, commissioned, operated and/or maintained by not or not adequate qualified personnel
- overloaded
- operated it with
 - defective security devices
 - not properly mounted or without security devices
 - not efficient safety- and protection devices
 - environmental conditions being not within the specified values
- you have reconstructed this appliance without written permission of Baumüller Nürnberg GmbH.
- you have disregarded instructions concerning maintenance in the component manuals
- you have failed to monitor parts of wear and tear properly
- you have carried out a repair job unskillfully
- you have unskillfully combined the appliance with products of other manufacturers
- you have combined the drive system with defective and/or incorrectly documented products of other manufacturers

The “General terms of sale and delivery“ of Baumüller Nürnberg GmbH apply generally. Those you have available at least since the contract has been confirmed.

- Training of personnel



Baumüller Nürnberg GmbH appliances must be assembled, installed, operated and maintained exclusively by the personnel qualified for the same.

Qualified Personnel

Qualified personnel are the persons, who, by virtue of their training, experience, instruction as also knowledge of the appropriate Standards and Regulations, regulations for prevention of accidents and operating conditions, have been authorised by the person responsible for ensuring safety of the plant, for carrying out the activities required in each case and for detecting the likelihood of any danger and for averting the same.

2.5 Structural changes in the appliance

Structural changes of any kind in the appliance without the consent of Baumüller Nürnberg GmbH in writing are prohibited.

2.6 Disposal of the appliance

Disposal of the appliance is described under [►Disposal◀](#) from page 79 onwards.

2.7 Fire fighting



WARNING

The following **may occur**, if you do not observe this warning information:

- serious personal injury
- death



*The hazard is: **Electricity while using a conducting fire extinguishing agent.***



Use this fire extinguishing agent:

ABC powder

3

PACKING AND TRANSPORTATION

Every Baumüller appliance has been packed by us before shipment, such that likelihood of any damage to the contents during transportation is very remote.

3.1 Transportation

The appliances are packed in the manufacturer's works in compliance with the P.O.

- ▶ Avoid heavy vibrations during transportation and powerful impacts, e.g. during unloading

3.2 Unpacking

After receipt of the still packed appliance :

- ▶ check whether any damage to the packing during transportation is noticeable.

if yes :

- ▶ lodge a complaint immediately with the supplier. Get a written confirmation and please get in touch immediately with your concerned agency of Baumüller Nürnberg GmbH.

- ▶

If no damage to the packing during transportation is noticeable:

- ▶ open the packing of the appliance.
- ▶ Check the scope of supply with reference to the delivery note.

The scope of supply is:

Product

- This Operation Manual incl. Declaration of Conformity
- Package containing fasteners

3.3 Disposal of the packing

- Lodge a complaint with the concerned agency of Baumüller Nürnberg GmbH if any damage during transportation is detected or if there is some deficiency in the consignment.



WARNING

The following **may occur**, if you do not observe this warning information:

- serious personal injury
- death

*The hazard is: **electricity**.*



Do not operate the appliance, if you have observed or fear any damage during transportation. In such a case, contact immediately, Baumüller Nürnberg GmbH.

3.3 Disposal of the packing

The packing consists of cardboard, plastic, metallic parts, corrugated paper and/or wood

- Pay attention to and observe the local regulations relating to the disposal, if you want to dispose off the packing .

3.4 Points to be observed during transportation

For the first transportation of the appliance, it is packed in the manufacturer's works. If the appliance is to be transported again at a later date, ensure that the following conditions are satisfied during the entire transportation

Make sure that the following conditions are complied with during the entire transportation :

- Climate class: 2 K 3
- Temperature range: 30 °C to + 70 °C
- max. drop height (packed): 0.25 m

DESCRIPTION OF THE APPLIANCE

This appliance is a feed-/feed back -unit with a B6-IGBT-transistor circuit, which is connected in series with the mains-choke. It converts the power drawn from the mains and supplies it to the DC link circuit of the BUS power-module (axes) connected.



NOTE

Do not use this appliance in residential areas (see Cl. 6.4.2.1 of EN 61800-3), as it may cause HF-disturbance in these areas.

4.1 Charging circuit for the DC link circuit

The charging circuit is the fixed constituent of the appliance which serves to avoid the charging current surges.

The charging circuit is switched off and the mains - contactor is switched on via the contact X1: 6/7 in the appliance after completion of precharging of the DC link circuit. The DC link circuit is charged to the rated voltage (P087 „DC link voltage“) set only after clearance of impulse to X26:14. The potential free relay contact X26:12/13 „ready for operation“/ (=ready for operation) on the V-controller is connected (see Description 5.03047) .

Freely programmable output (end) of the V-controller can for instance be used for passing on the message : ready for operation to the axes connected.

The digital BUC controller ensures maintaining a constant DC link voltage and guarantees a power factor of $\cos \varphi = 1$ at every operating point.

4.2 Variants

The single - power -module BUC64 is available in 3 variants , which differ in the design of the cooling system (S/A/F) :

- **S**: Appliance for the control cabinet (Air cooler inside the control cabinet)
- **A**: Through plugging variant **A** (Air cooler outside the control cabinet)
- **F**: Through plugging variant **F** (Water cooler outside the control cabinet)

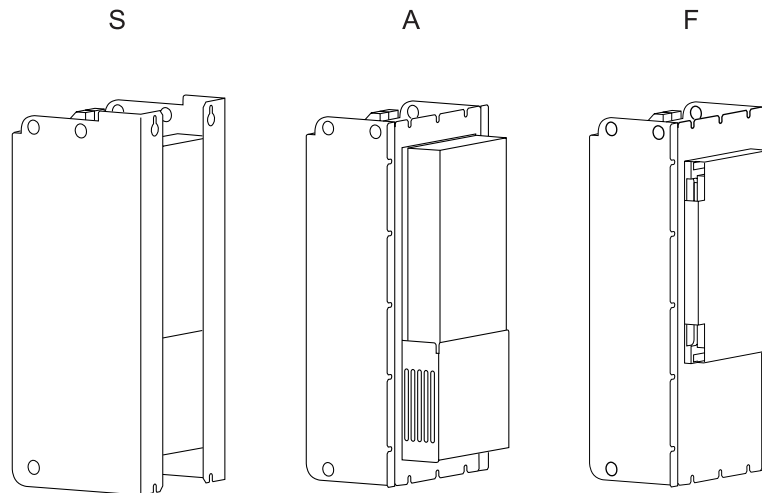

Figure 1: Cooling variants

001_rev01_int.cdr

4.3 General overall view with hazard areas

The general overall view below indicates the hazard areas present in the respective appliances. It offers an overview of the hazard areas that the user may come across while handling this appliance.

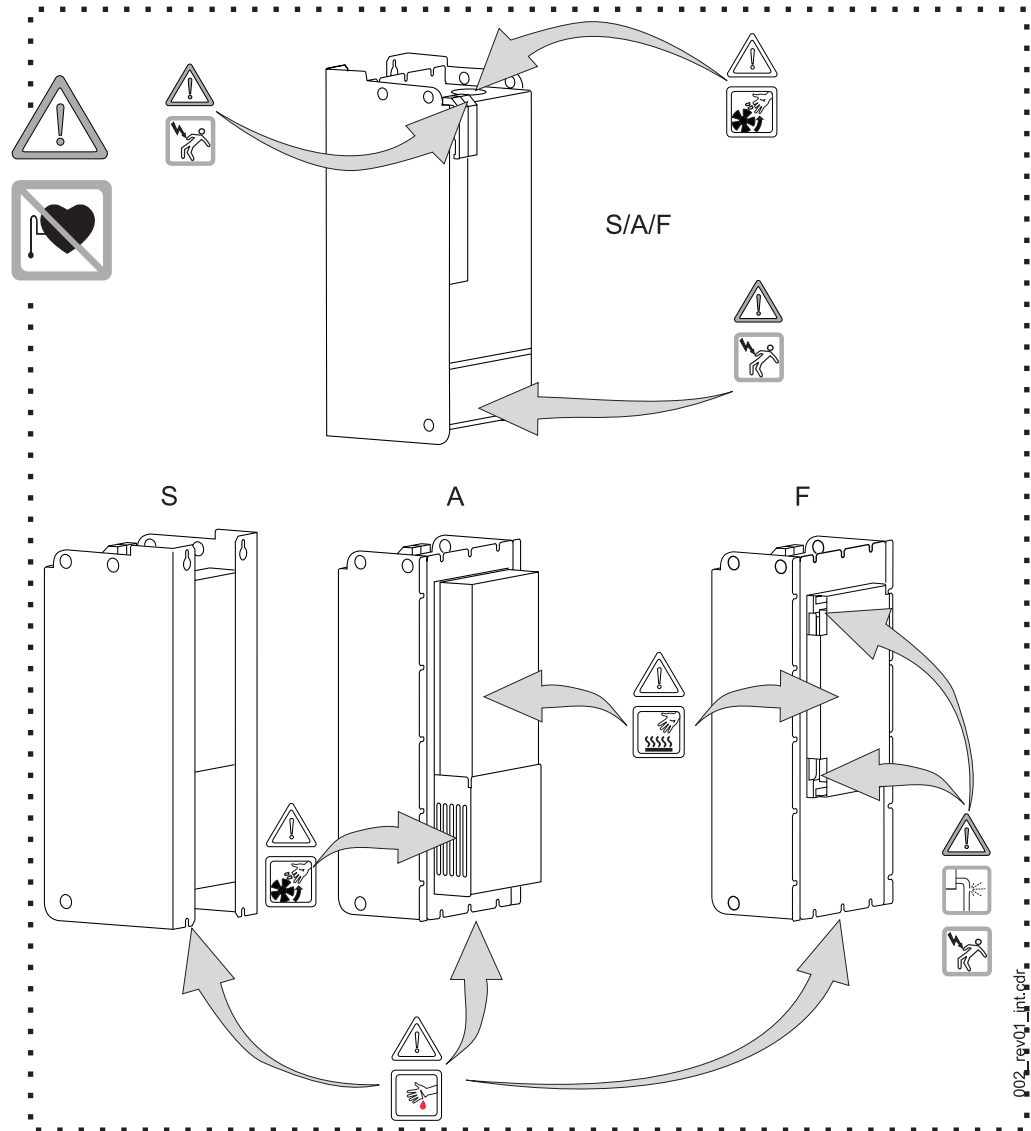

Figure 2: Hazard areas

4.4 Identification markings on the appliance - type key

4.4 Identification markings on the appliance - type key

The type key and the series no. of the appliance are indicated on the identification plate (affixed inside on the side wall of the appliance, see figure below).

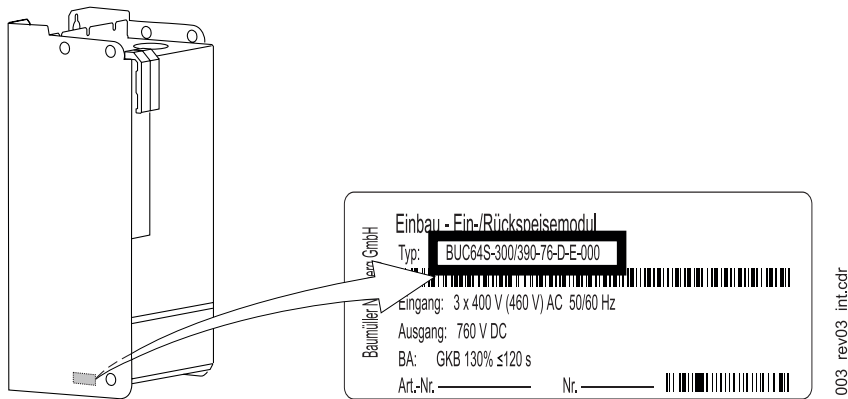

Figure 3: Identification plate with Type key

BUC64X - XXX/XXX - XX - X - X - XXX BAUMÜLLER feed-/feed back Module

BUC64X - XXX/XXX - XX - X - X - XXX Type series

BUC64X - XXX/XXX - XX - X - X - XXX Size

BUC64X - XXX/XXX - XX - X - X - XXX Type of cooling

S: Air cooled with arrangement for supplying air and its removal inside the control cabinet

A: Air cooled with arrangement for supplying air and its removal outside the control cabinet

F: Water cooled with arrangement for supplying air and its removal outside the control cabinet

BUC64X - XXX/XXX - XX - X - X - XXX Nominal input current in ampere at ambient - and cooling medium temperature of 40° C and cycle frequency of 4 kHz

BUC64X - XXX/XXX - XX - X - X - XXX Peak input current in ampere at ambient - and cooling medium temperature of 40° C and cycle frequency of 4 kHz, $t \leq 2$ min

BUC64X - XXX/XXX - XX - X - X - XXX Rated -DC link voltage x 10 [V]

BUC64X - XXX/XXX - XX - X - X - XXX controller rated execution

D: digital (V-controller cassette)

BUC64X - XXX/XXX - XX - X - X - XXX Chopper resistor

O: without chopper resistor circuit

E: with chopper resistor circuit, external resistance

BUC64X - XXX/XXX - XX - X - X - XXX Status of development

Only a part of the Technical Data can be found on the identification plate. Compilation of all the Technical Data can be found [▶Appendix D - Technical Data◀](#) from page 93 onwards.

4.5 Block circuit diagrams

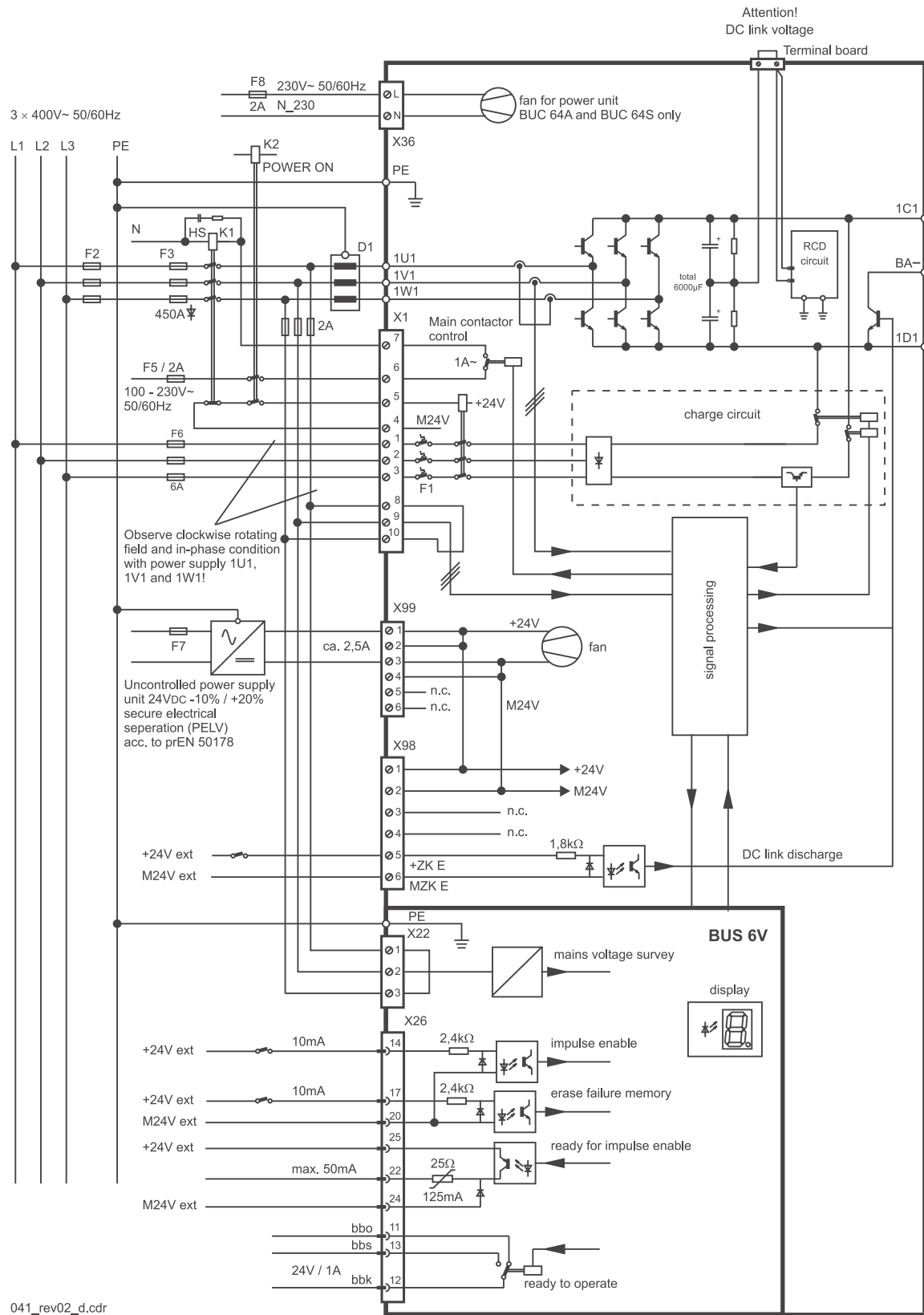

Figure 4: Block circuit diagram BUC64S/A/F

4.5 Block circuit diagrams

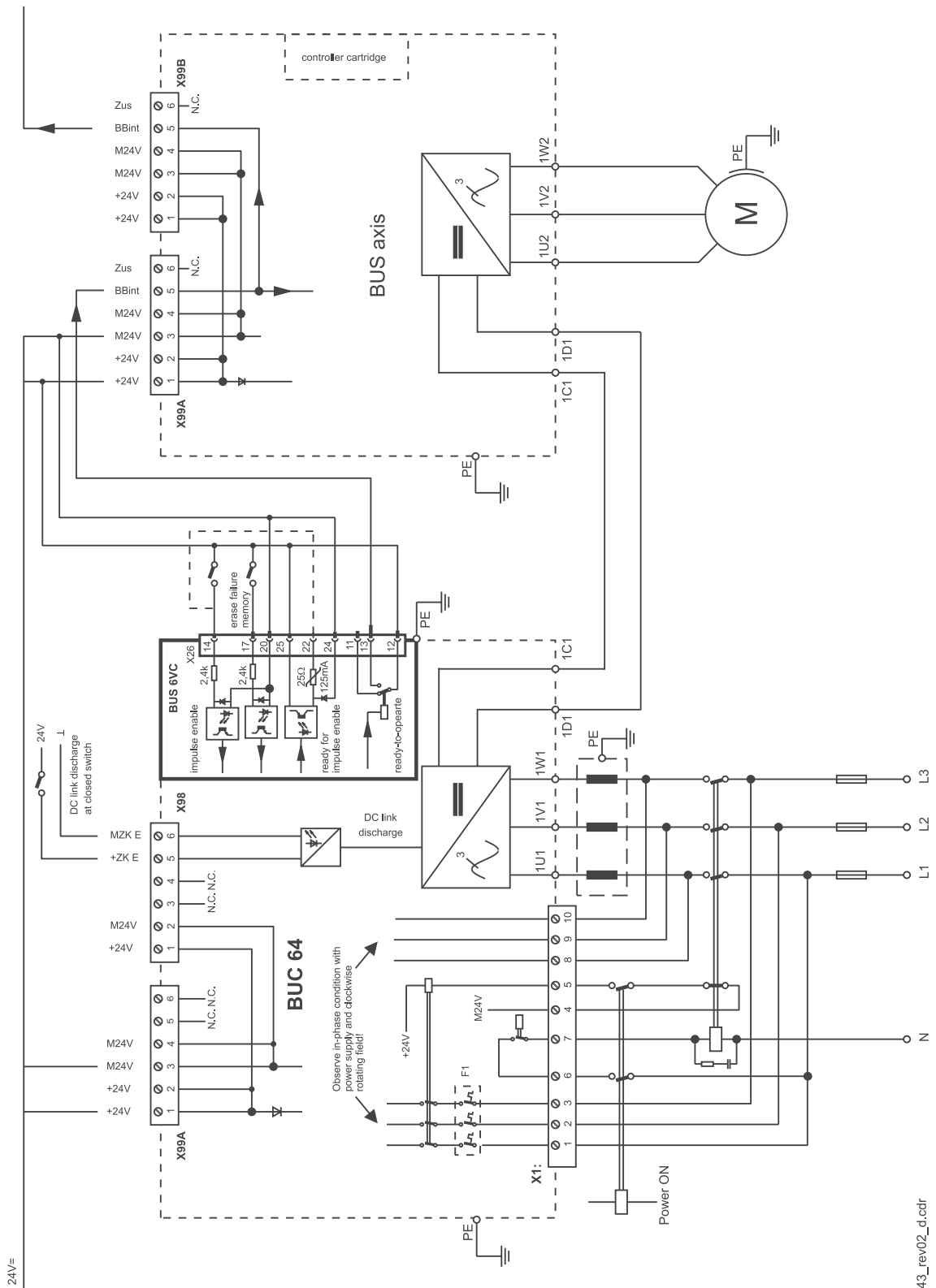
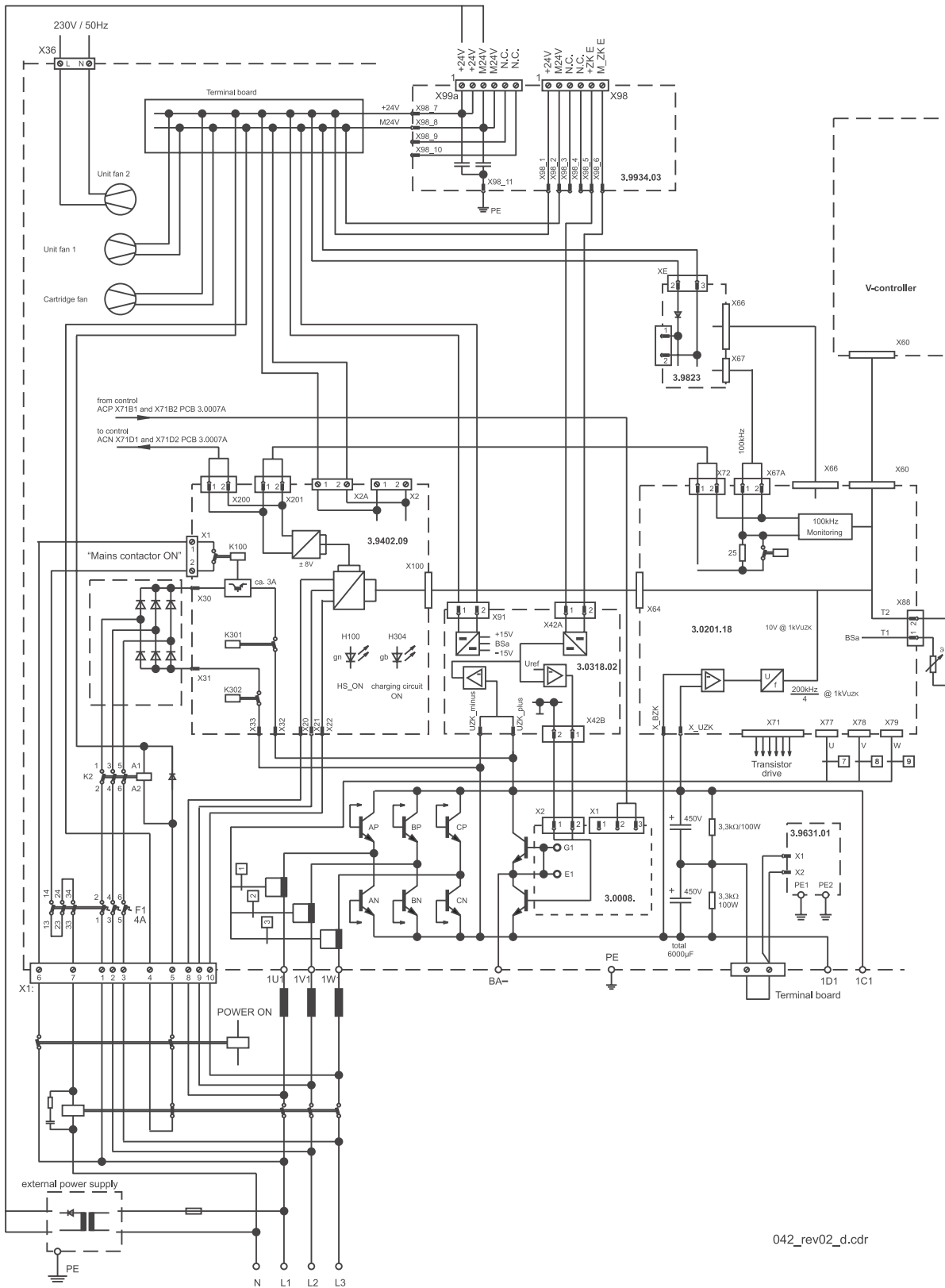

Figure 5: Connection : BUS - BUS

043_rev02_d.cdr

4.6 Construction drawing



042_rev02_d.cdr

Figure 6: Construction drawing BUC64-300A/390A Part 1

4.6 Construction drawing

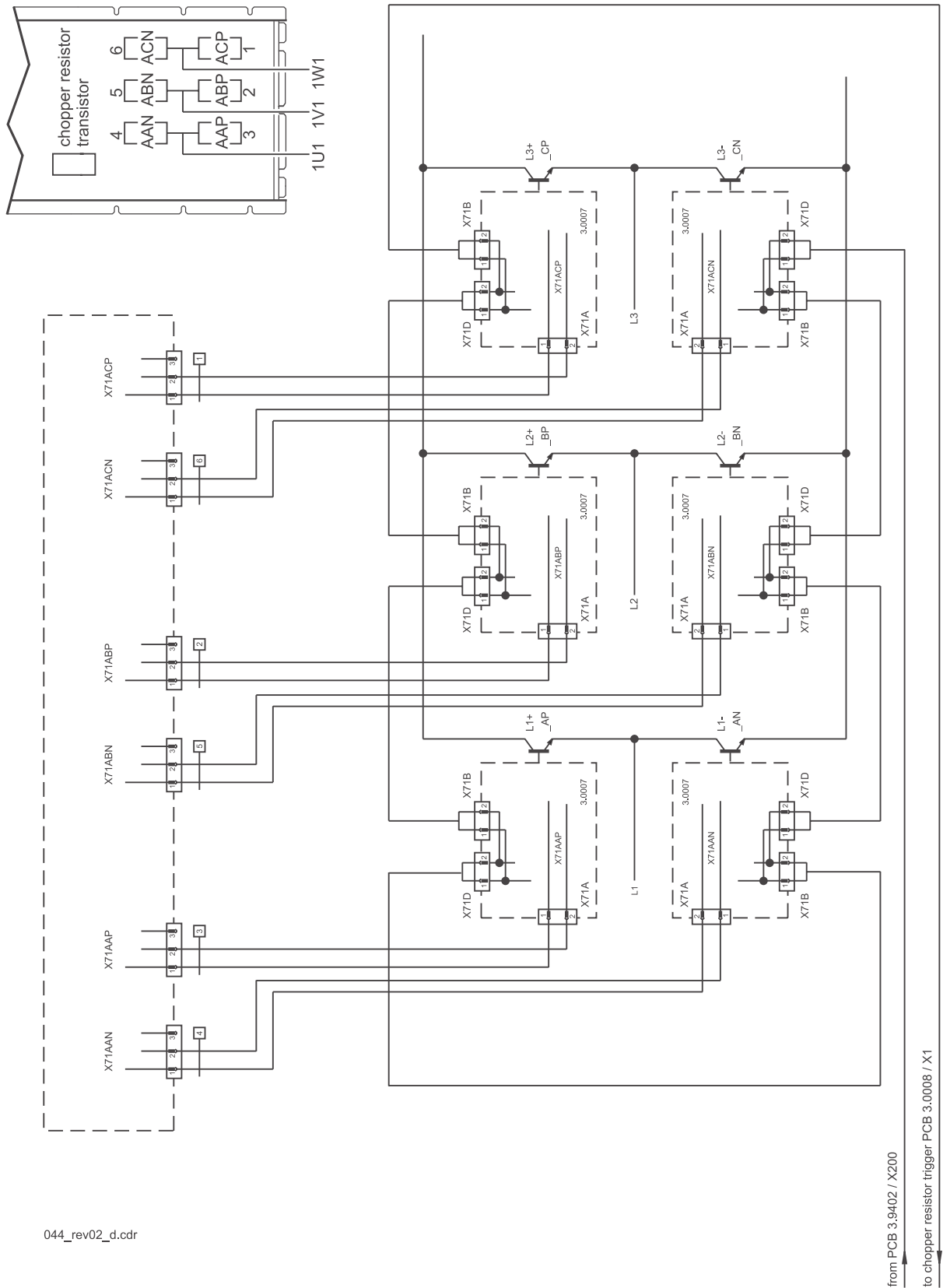
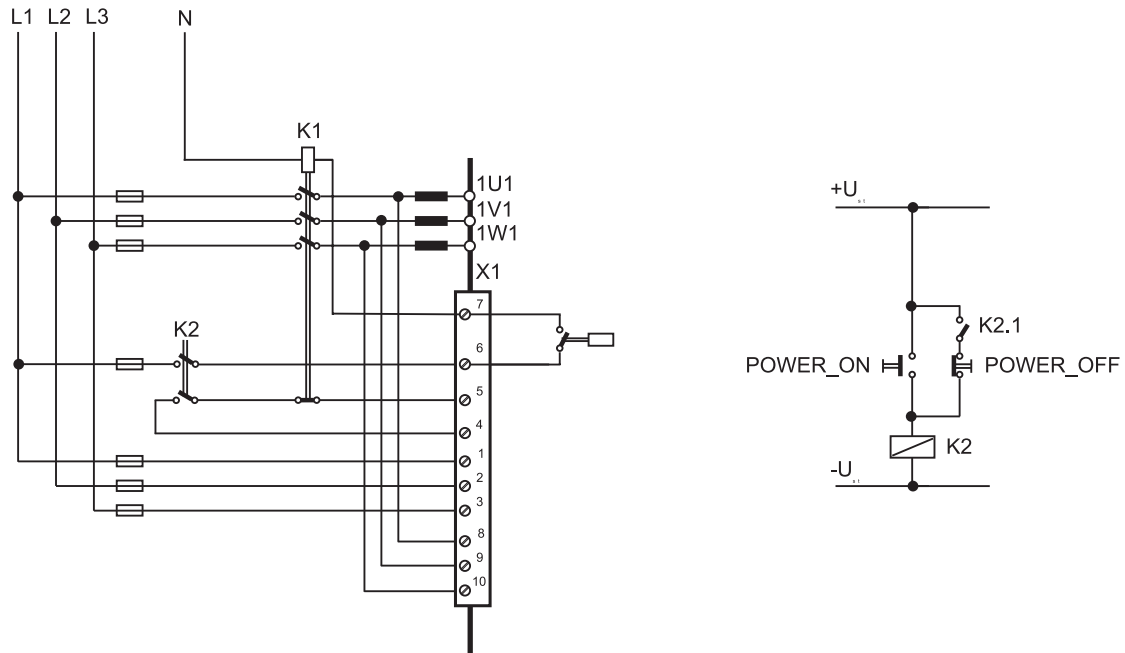

Figure 7: Construction drawing BUC64-300A/390A Part 2

4.7 Suggestion for controlling Power On/Off

3 × 400V~/460V~ 50/60Hz



040_rev02_d.cdr

Figure 8: Suggestion for controlling Power On/Off

4.7 Suggestion for controlling Power On/Off

MOUNTING

It must be ensured by adopting suitable additional measures that the requirements of Cl.5.2.4 of EN 50178/ VDE 0160 and Cl.6.2.2 of EN 60204-1/ VDE 0113, Part 1 are satisfied, if the appliances are to be set up in closed electrical workshops as per Cl 5.2.7 of EN 50178/ VDE 0160.

5.1 Hazard areas during mounting

The general overall view below indicates the hazard areas present on the appliance, which are important for the mechanical mounting



Use this overview exclusively for the mechanical mounting. Hazards resulting from electricity are not shown here. These will be indicated under [▶Hazard areas during mounting◀](#) on page 35 onwards

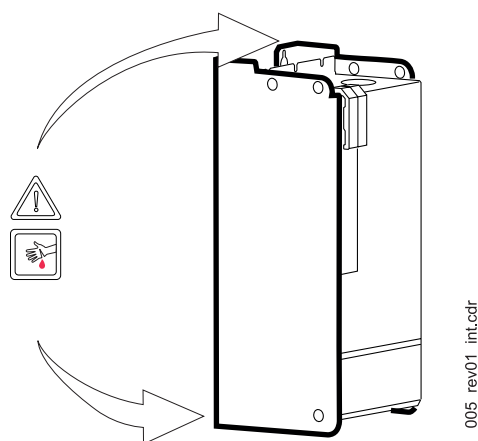

Figure 9: Hazard areas during mounting

5.2 Sequence of mounting

The sequence for mechanical mounting is indicated below :

- selection of the control cabinet.
- drilling of hole/cutting threads and recess (only for variant A/F).
- mounting the module.
- connecting the cooling circuit/system (only for variant F), check for leakage and impressions, if any.

Further additional information on the above mentioned steps is given below in detail .

5.2.1 Selection of the control cabinet

BUC64S/A/F-Modules are appliances that are installed inside within the meaning implied by Cl. 5.2.6 of EN 50178/VDE 0160 . They are meant for installation in commercial control cabinets complying with the minimum requirements for type of protection as specified at Cl. 5.2.4 of EN 50178/VDE 0160, (IP 2X, if required, also IP4X as per EN 60529/5.1).



WARNING

The following **may occur**, if you do not observe this warning information:

- serious personal injury
- death



*The hazard is: **mechanical effect**. Depending on the design execution, the appliances weigh about 65kg to 88kg.*

Select a control cabinet which can bear this weight permanently.



NOTE

- The thickness of the rear panel must not exceed 6 mm, if a through plugging variant (F/A) is to be mounted.

5.2.1.1 Installation space - dimensioned diagrams

Use the dimensioned diagrams below for specifying the space required for installation in the control cabinet.



CAUTION

The following **may occur**, if you do not observe this caution information:

- property damage.

The hazard is: overheating of the appliance.

Make arrangements for taking away the heat generated by the appliance. See to it that there is no obstruction to supply and outlet of the cooling medium.

Pay attention to the required temperature and the quantity of the cooling medium (see [▷D.3 Required ambient conditions](#) on page 94). If required, fit additional fans on the control cabinet.

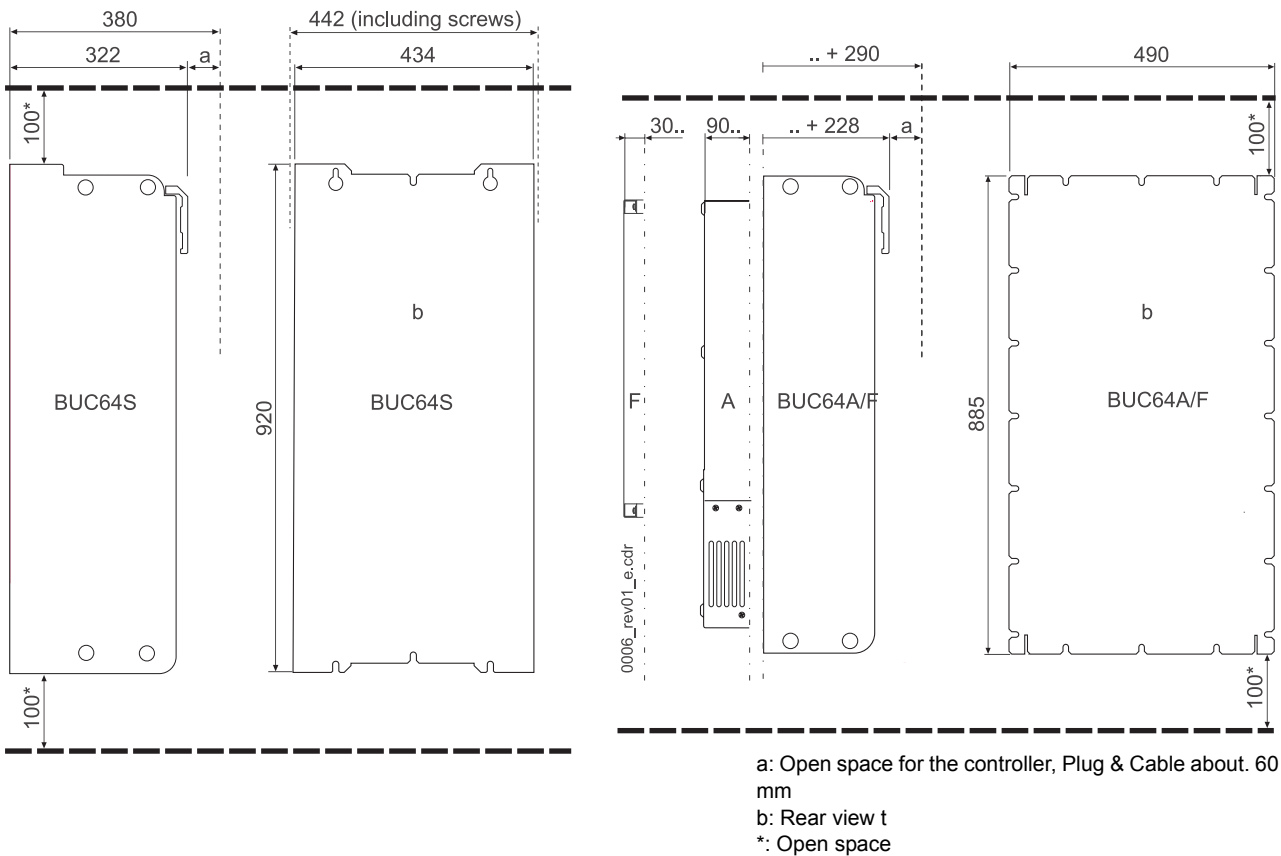
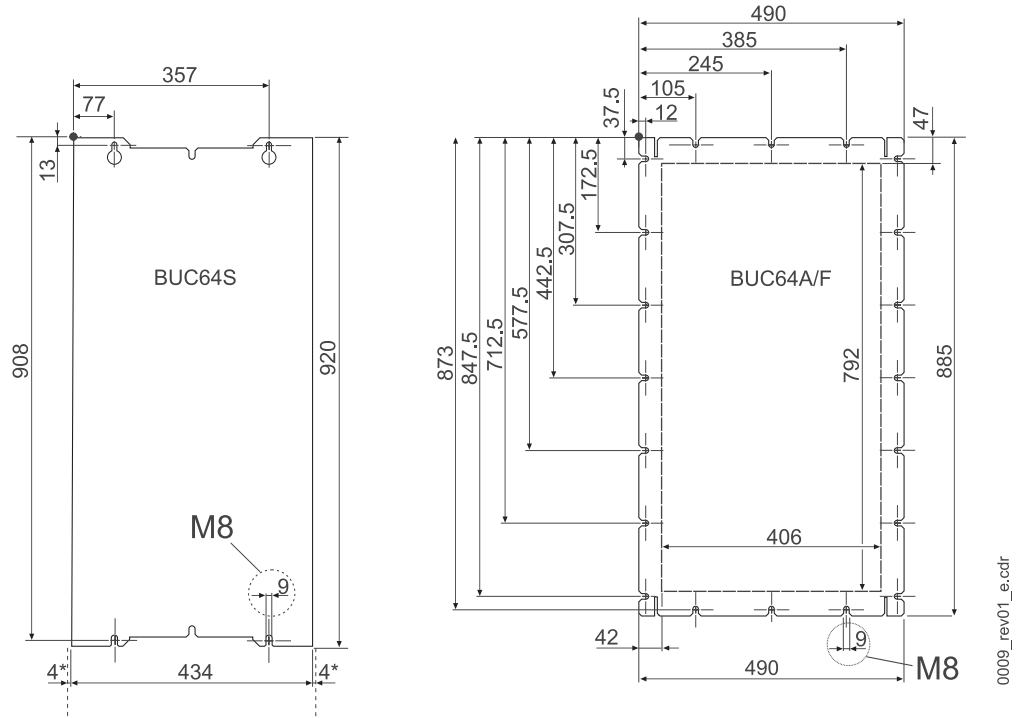

Figure 10: Dimensioned diagram BUC64S/A/F

5.3 Drilling of holes/cutting threads and the recess

- drilling of hole/cutting threads and recess (only for variant A/F) as indicated in the drilling diagrams below



* Screw head

Figure 11: Drilling Diagram/Pattern BUC64S/A/F

0009_rev01_e.cdr

5.4 Mounting the appliance

- 1 screw the rear panel of the appliance to the rear panel of the control cabinet .
- 2 mount all the screws for ensuring the EMV of the appliances.

5.4.1 Mounting the BUC64S



CAUTION

The following **may occur**, if you do not observe this caution information:

- minor to medium personal injury.

*The hazard is: **sharp edges***

Take the weight of the appliance into account - the appliance weighs about 88kg.

Lift the appliance by using a suitable device and / or employing personnel having suitable qualifications.



carry safety gloves

5.4 Mounting the appliance

Screws (A)	4 x M8			
Washers (B)	4 x (8.4 x 17)			
Spacing of mounting (c)	c = 7 mm			

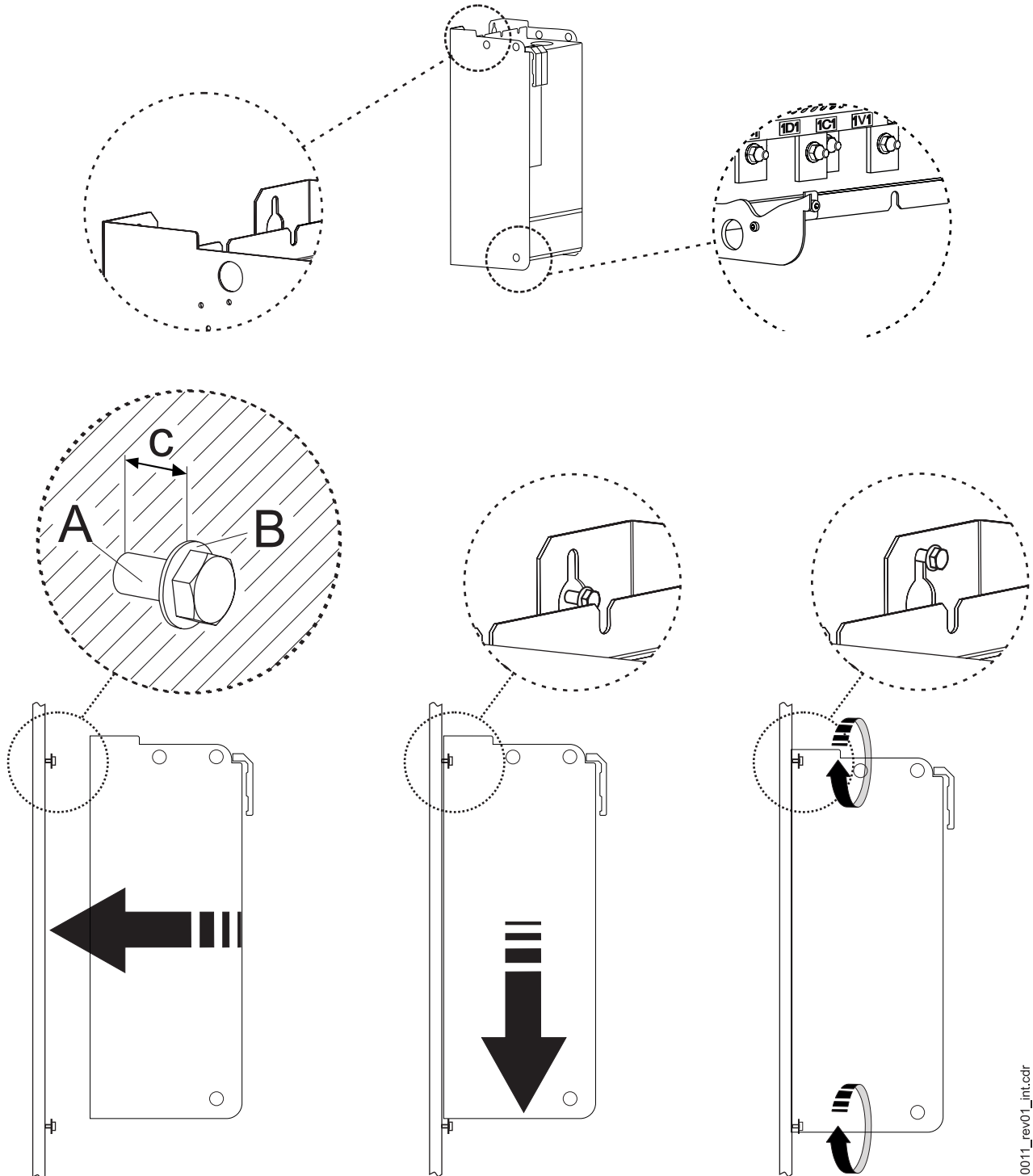

Figure 12: Guidelines for mounting of BUC64S

0011_rev01_int.cdr

5.4.2 BUC64 mounting the through plugging variant A/F

CAUTION



The following **may occur**, if you do not observe this caution information:

- minor to medium personal injury.

*The hazard is: **sharp edges***



Take the weight of the appliance into account -
- the appliance weighs about 65kg (F) or 80kg (A).

Lift the appliance by using a suitable device and / or employing personnel having suitable qualifications.



carry safety gloves

WARNING



The following **may occur**, if you do not observe this warning information:

- serious personal injury
- death



*The hazard is: **electrically conducting fluid in conjunction with electricity**. If water comes out of a water cooled appliance, then it may percolate in the control cabinet if the sealing is not proper and further this water may then come in contact with the parts carrying dangerous magnitudes of voltage.*



Make sure that the seal on the rear side of the appliance has not been damaged. The appliance should be mounted only if this seal is intact.

5.4 Mounting the appliance

Screws (A)	16 x M8				
Washers	16 x (8.4 x 17)				
Seal	see accessories				

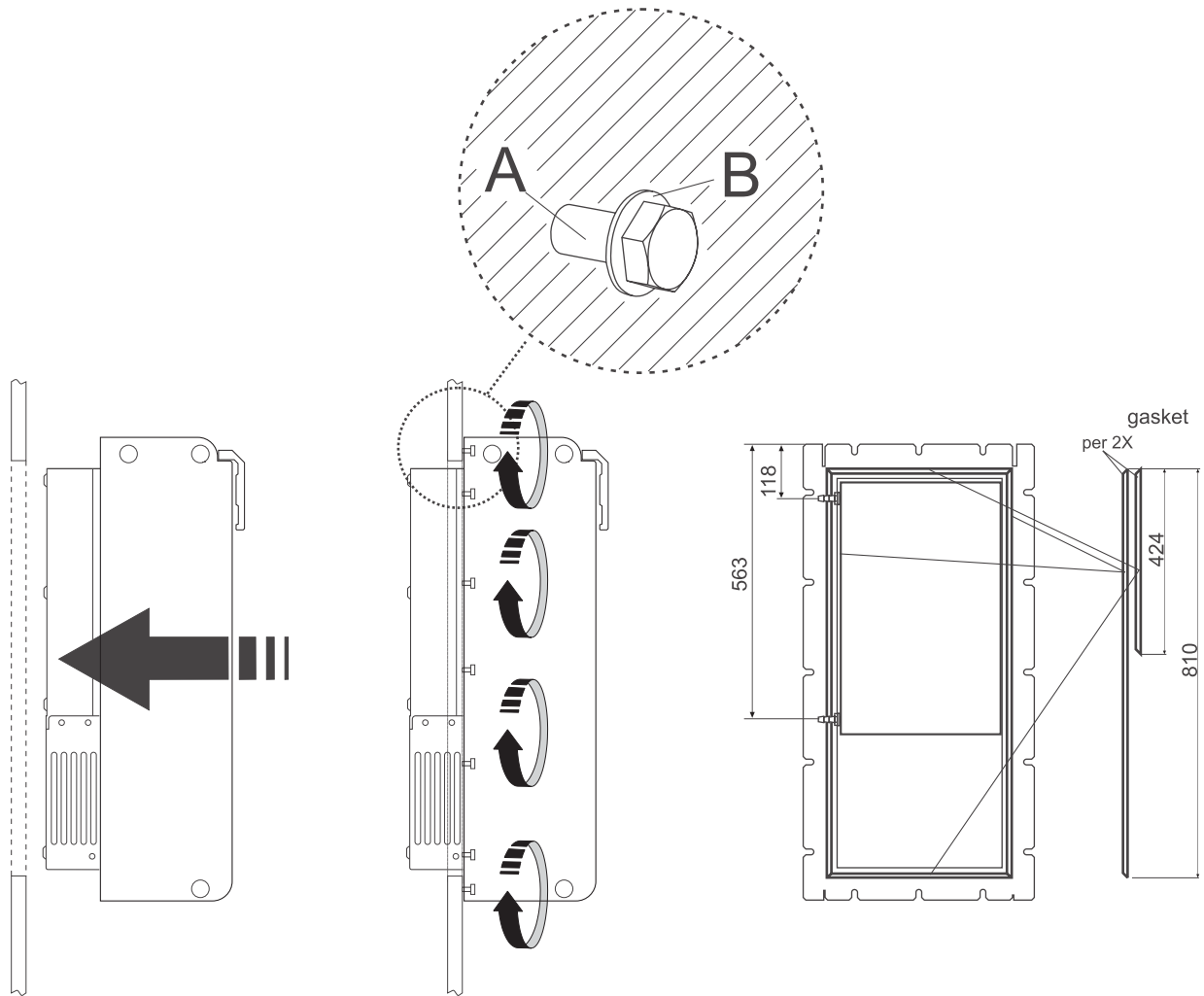

Figure 13: Guidelines for mounting of BUC64 through plugging variant A/F

5.4.2.1 Cooling medium

The cooling medium must satisfy certain requirements, which are stated in [►D.3 Required ambient conditions◀](#) on page 94.

WARNING

The following **may occur**, if you do not observe this warning information:

- serious personal injury
- death



*The hazard is : **electrically conducting fluid in conjunction with electricity**. The heat sink may get corroded and start leaking , if a wrong cooling medium is used . If for instance, the heat sink is leaking, then the cooling water may come out of the cooling circuit/system , percolate in the control cabinet and come in contact with parts carrying dangerous magnitudes of voltage.*



Mix corrosion preventing medium (in the cooling medium); use only one brand !

Maintain the mixing proportion constant without fail and check it at regular (maintenance) intervals specified (see [►Service intervals◄](#) from page 73 onwards).

Pay attention to and observe the safety instructions of the manufacturer of the corrosion preventing medium and the safety data sheets as per the EU- Richtlinie/(=Guideline) 91/155/ EWG and/or the currently relevant national Guidelines to be followed in the country of use.

Water pollution classes (WGK) specified by the manufacturer have to be followed for the disposal of the cooling medium. Since 17. May 1999, the class 0 is not there any more in accordance with VwVwS (Administrative Regulation for substances causing pollution of water). Starting with class 1 (mild pollution, Germany), the degree of water pollution increases with higher class numbers. In any case, the disposal must be carried out in accordance with the Regulations, the local authority responsible for drain water must be approached. Disposal in canals - even in diluted form - is not allowed.

CAUTION

The following **may occur**, if you do not observe this caution information:

- property damage.

*The hazard is : **damage to the cooling circuits***

Prevent use of cooling cum lubricating medium from the (machining) process as a coolant!

cooling circuits must remain in filled condition after filling with a mixture of the cooling medium and water for preventing corrosion at the phase boundary between liquid and air.

Make sure that, after filling, there are no air pockets in the cooling circuit.

Residues of the cooling medium can have an oxidising effect, result in lowering the pH-value and have a corrosive effect in the acidic pH-value - range.

While changing the cooling medium or changing over to another medium, see to it, that the cooling circuit is flushed thoroughly with water.

If, cooling circuit filled with a mixture of cooling medium and water have to be emptied and are not to be refilled within a span of a few days, then also it is necessary to flush these several times with water, followed by complete emptying.

5.4 Mounting the appliance

5.4.2.2 Connecting the cooling medium - circuit

The appliance BUC64F comes with a heat sink already mounted on its back side. The topmost threaded hole (G1/8") in the heat sink and the one of the same size at the extreme bottom are meant for fitting the supply and outlet - unions to the cooling (medium) system. Use unions with male threads G1/8" for connecting to the cooling (medium) system. Supply and outlet hoses are mounted on these unions.

The BUC64F is mounted in the control cabinet. After that, fit the heat sink connections/ (unions) which are accessible on the back side of the appliance.

Mounting of the connections for the heat sink :

- 1 keep suitable connections ready (material: brass, threads: G1/8")
- 2 clean the threaded holes and threaded unions.
- 3 apply silicon sealing material, e.g. Loctite 5331 on at least one (clean!) threaded course of the unions.
The silicon sealing material prevents corrosion between different materials and increases the safety/leakproofness.
- 4 Turn in by hand, the unions in the threading in the heat sink and tighten with maximum permissible torque.



CAUTION

The following **may occur**, if you do not observe this caution information:

- property damage.

The hazard is : damage to the threads of the union

never tighten by applying torque more than the one permissible (6 Nm) .

- 5 connect the supply by one of the two unions.
- 6 connect the outlet by using the other union.



NOTE

Any direction of flow can be used and is permissible.

- 7 Check the cooling circuit for leakage
- 8 press down the cooling circuit by applying the specified test pressure (12 bar or more).

6

INSTALLATION

The electrical installation of the appliance is described in this chapter. The mechanical mounting has been described in the chapter [►Mounting◄](#) from page 35 onwards.

The steps involved in installation are as follows :

- 1 Ascertain the requirements of the mains and check, whether the existing mains is suitable.
- 2 Ascertain the requirements of the electrical cables and keep the required cables ready.
- 3 Ascertain the properties of the terminals and configure the cables accordingly .
- 4 Lay the cables in accordance with the EMC .

6.1 General indications of hazards

The appliances BUC64S/A/F are operating material pertaining to the protection class I Cl 3.2 of HD366 S1, also see Cl.5.2.9 of EN 50178/VDE 0160

Operating material pertaining to the protection class I are the materials, whereby the protection from hazardous body currents is based not only on the basic insulation and as a result, cover additional safety precautions . This additional protection is obtained by connecting the body/case and other parts by a protective conductor, so that in case of failure of the basic insulation, no voltage can be retained. The insulation of these appliances is designed as per Cl. 5.2.9.1 of EN 50178/VDE 0160, the overall characteristics, at least as per the basic insulation. This applies to the insulation between the circuits and the surrounding.

The control terminals of the appliances are isolated safely from the mains and designed for connection of the PELV-/SELV-circuits.

The following criteria were taken into consideration while designing the air and leakage paths :

- Pollution level 2 as per Cl. 5.2.15.2, Table 2, line 3 of EN 50178/VDE 0160 : In the normal case, there takes place just a nonconducting pollution. When the appliances are out of order, then an occasional conductivity for a short duration is possible due to dewing.
- Overvoltage category III as per table 1, IEC 664-1 for the air paths of the mains circuits against their surrounding as per Cl. 5.2.16.1 of EN 50178/VDE 0160.

The appliances BUC64S/A/F are **short circuit proof under certain conditions** as implied in Cl.6.3.4 of EN 50178/VDE 0160.

There always occur current leakages to earth in the rectifier and in the motor during the operation. These leakage currents must be taken away via the protective conductor terminals specified.

Protection against direct contact of the units is obtained by installing the rectifiers in commercial quality control cabinets complying the minimum requirements of type of protection as per Cl. 5.2.4 of EN 50178/VDE 0160 and Cl. 12.4 of EN 60204-1.

Plastic covers fitted to the units, covering the control terminals, offer additional protection against contact during commissioning and "occasional handling" of the operating elements arranged in the vicinity .

Furthermore, there is a metal bridge below the plastic cover on the right, by the side of the control terminals. This bridge lies at the **DC link circuit potential** via the 2 terminals (see >Figure 2< on page 27 above and >Figure 4< on page 29 top right) **and hence, pay attention to the discharge time of the DC link circuit before opening the plastic cover !**

Additional measures must be adopted for the power terminal.

(IEC 60536-2, Cl. 5.1.1, Regulation for prevention of accidents "Electrical equipment and operating materials" VBG4).

Protective measures and safety regulations as per DIN/VDE are important for protection of human beings.



WARNING

The following **may occur**, if you do not observe this warning information:

- serious personal injury
- death

*The hazard is: **electricity***

There are bound to be personal injuries in absence of protective conductor terminals on the unit or on the motor .

Connect the protective conductor. Operate the units only on the supply networks provided with earthing connection !

The discharge time of the parts carrying voltage is > 1 min.

Before working on the parts carrying voltage, check by using suitable measuring instruments, that the parts are not carrying any voltage. Do not touch the parts until you have convinced yourselves about their being free from any voltage and the unit and the motor are secured against getting switched on.

6.1.1 Voltage test

Voltage test as per Cl. 9.4.5 of EN 50178/VDE 0160 is carried out by Baumüller Nürnberg GmbH during item wise testing of these units.

**WARNING**

The following **may occur**, if you do not observe this warning information:

- serious personal injury
- death

The hazard is: electricity

Testing of the unit at high voltage at a later stage has to be carried out, if required, by Baumüller Nürnberg GmbH only.

If the complete installation of the control cabinet without the Baumüller-unit is to be tested for high voltage, then all the cable connections have to be removed from the same before carrying out such testing.

6.2 Hazard from areas during installation

The general overall view below indicates all the areas of the appliance, which may be prone to hazards during the electrical installation.

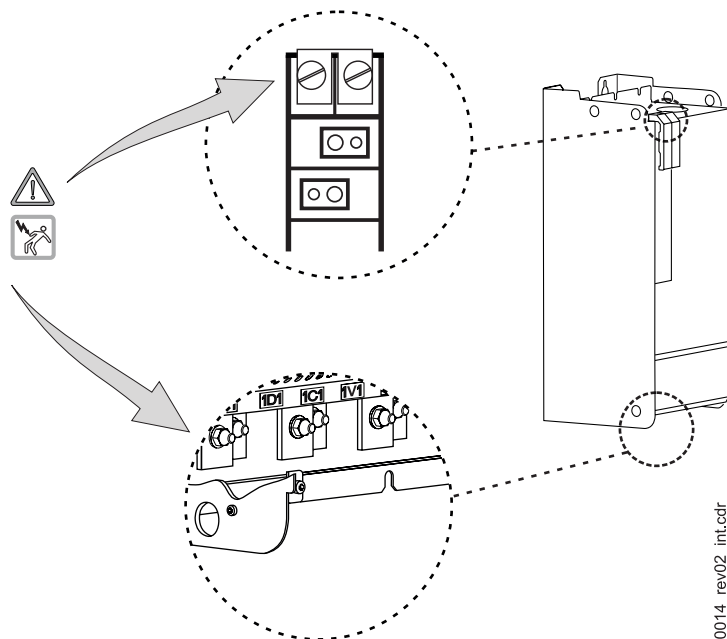

Figure 14: Hazard prone areas

6.3 Requirements of the cables

The data, such as ambient conditions, electrical (connected) power data, etc. which has to be taken into consideration while selecting the cables can be found under the Technical Data ([►Appendix D - Technical Data◀](#) from page 93 onwards) .

Further additional information can be found in the Annexes under [►Cable : control voltage supply/ signals◀](#) on page 99 and [►Cable : power connection◀](#) on page 99.

- Make sure, that all the cables comply with the requirements.

6.4 Terminals

Detailed information on all the terminals can be found here. Summary thereof can be found in the [▶Connection diagram BUC64S/A/F, with ballast◀](#) on page 60.

6.4.1 Power terminals

These are located on the bottom side of the appliance (see [▶Figure 15◀](#) on page 48).

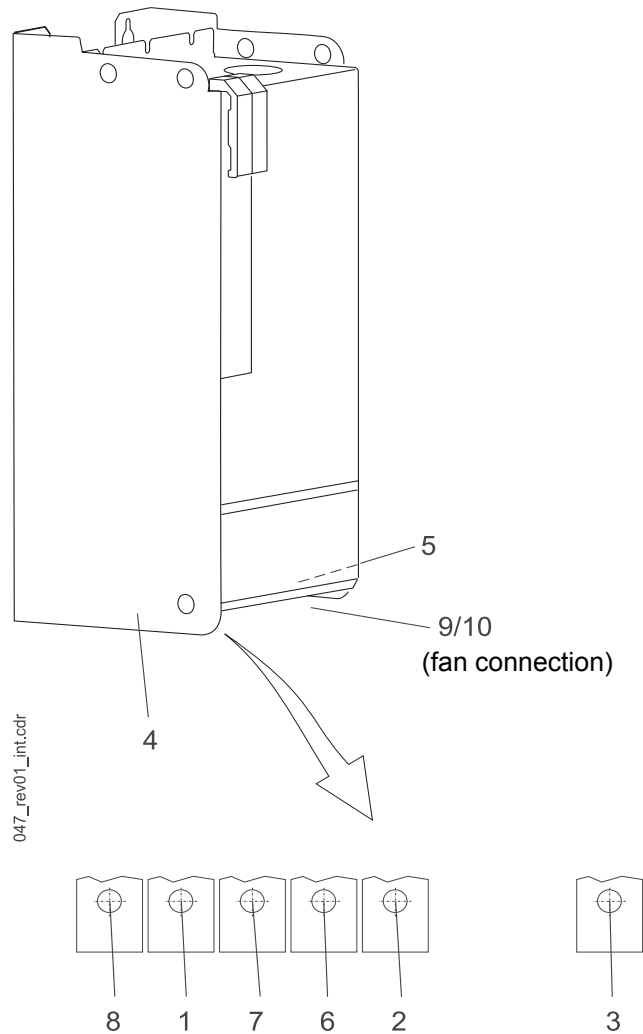

Figure 15: Power terminals

Terminal ¹⁾	Pos. ²⁾	Description	Voltage range (U_{Bereich})	Current range (I_{Bereich})
1U1	1	Mains Terminal Phase L1	400 - 460 V _{AC} ±10 %	300/390 A _{AC}
1V1	2	Mains Terminal Phase L2		
1W1	3	Mains Terminal Phase L3		
⊕	4	Earthing Connection		
⊕	5	Earthing Connection		
1C1	6	+ Terminal, DC link	640 V _{DC} to 760 V _{DC} ³⁾	320 / 485 A _{DC} to 270 / 410 A _{DC}
1D1	7	- Terminal, DC link		
Ba-	8	Terminal for ballast resistance, Terminal of the resistance between 1C1 and Ba-		max. 130A _{DC}
X36:L	9	Fan Terminal ⁴⁾	230 V _{AC} +5 % -10 % 50 / 60 Hz	1 A _{AC}
X36:N	10			

¹⁾ Select the terminal - cross section as depending on the (case of) application in accordance with the relevant standards (e.g. DIN VDE 0100-430) .

see [▶ Cable : power connection◀](#) on page 99

²⁾ Position, see [▶ Figure 15◀](#) on page 48.

³⁾ DC link voltage depends upon setting of the Parameter P087 „DC link voltage“ at the V-regulator.

⁴⁾ Is applicable only for the cooling variants S and A. The 2-pole terminal x36/ N and L for the fan terminal on 230 V is on the right, at the bottom of the appliance in the area where the power terminals are located, see [▶ Figure 26◀](#) on page 60.

6.4.2 Control terminals



WARNING

The following **may occur**, if you do not observe this warning information:

- serious personal injury
- death



*The hazard is: **Electricity***

Prevent overloading of the control terminals. The max. permissible current of 10 A per terminal point must not be exceeded.

Assure, that current is supplied several times, where higher currents are required .

Also make sure that all the control voltage applied externally meet the regulations for PELV or SELV .

6.4 Terminals

6.4.2.1 Control terminal X99A

Use the plug-in terminals supplied along with for connecting X99A. Additional plug-in terminals required, if any, can be obtained from Baumüller Nürnberg GmbH or directly from the manufacturer (see [B.2 Plug](#) on page 86).

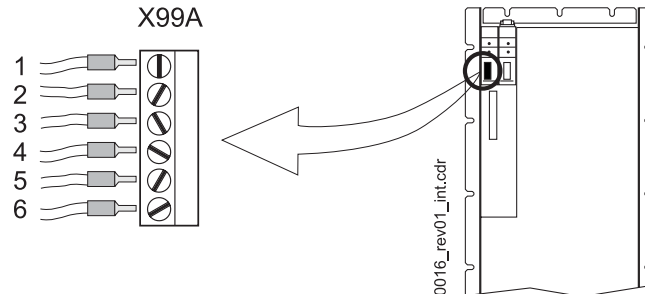

Figure 16: Control Terminal X99A

Terminal ¹⁾	Pos. ²⁾	Description	Volt. range U_{Bereich}	Current range I_{Bereich}
+24 V	1	+ 24 V (PELV) ³⁾ Terminals 1 and 2 are bridged internally	24V DC -10% / +20%	2,5 A _{DC}
+24 V	2			
M 24 V	3	Ground 24 V (PELV) ³⁾ Terminals 3 and 4 are bridged internally		
M 24 V	4			
	5	not occupied		
	6	not occupied		

¹⁾ permissible cross section of the conductor - terminal , see [Cable : control voltage supply/ signals](#) on page 99.
Pay attention to the EMC instructions while doing the connections: see [Requirements for laying the cables \(EMC instructions\)](#) on page 53.

²⁾ Position, see [Figure 16](#) on page 50

³⁾

NOTE



Max. permissible current for each terminal : 10 A . Use 2 terminals, where higher currents are required , total 20 A current is then possible.

6.4.2.2 Control terminal X98

Use the plug-in terminals supplied along with for connecting X99A. Additional plug-in terminals required, if any, can be obtained from Baumüller Nürnberg GmbH or directly from the manufacturer (see [►B.2 Plug◄](#) on page 86).

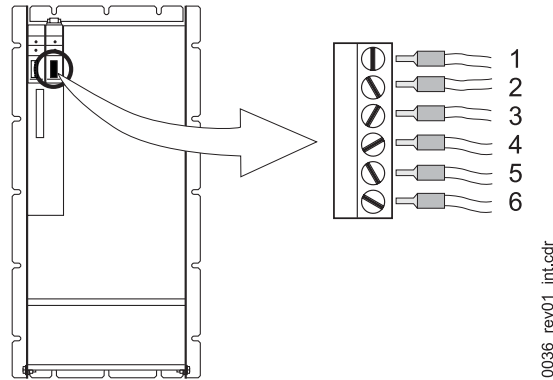
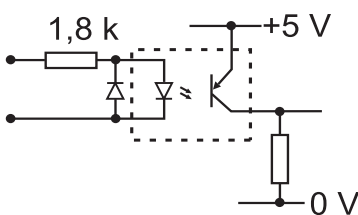

Figure 17: Control Terminal X98

Terminal ¹⁾	Pos. ²⁾	Description	Volt. range U_{Bereich}	Current range I_{Bereich}
+24 V	1	+ 24 V (PELV)	24V DC -10% / +20%	max. 10A _{DC}
M 24 V	2	Ground 24 V		
	3	not occupied		
	4	not occupied		
+ ZK E	5	isolated optocoupler input for discharge of the DC link circuit. 	24 V _{DC}	about. 15mA _{DC}
M_ZK E	6	Ref. point for input + ZK E (terminal 5)		-

1) permissible cross section of the conductor - terminal , see [►Cable : control voltage supply/ signals◄](#) on page 99.
Pay attention to the EMC instructions while doing the connections: see [►Requirements for laying the cables \(EMC instructions\)◄](#) from page 53.

2) Position, see [►Figure 17◄](#) on page 51.

6.4 Terminals

6.4.2.3 Discharge circuit - terminal X1

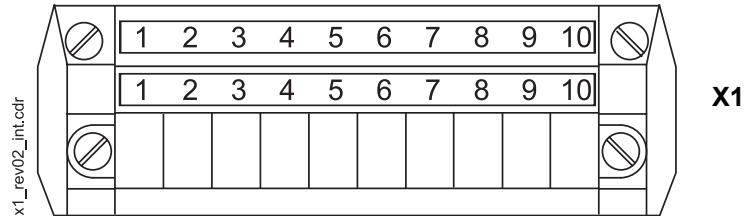

Terminal No.:	Occupation/(connection to)
	Supply to the loading circuit
1	Phase L1 Mains voltage, 4A _{AC}
2	Phase L2 Mains voltage, 4A _{AC}
3	Phase L3 Mains voltage, 4A _{AC}
	Charging Contactor off
4	Aux. contact, main contactor (opener), max. 0,5A _{DC}
5	Aux. contact, main contactor (opener),
	Main Contactor on
6	Release contact, main contactor
7	For connecting the coil of the main contactor, max. 230V _{AC} /1A _{AC}
	Mains terminal monitor (Power pack)
8	Phase L1 Mains voltage after the main contactor, max. 5mA
9	Phase L2 Mains voltage after the main contactor, max. 5mA
10	Phase L3 Mains voltage after the main contactor, max. 5mA

6.5 Requirements for laying the cables (EMC instructions)

Semiconductors which minimize the power leakage by fast switching and thus enable reducing the size of the gadget are used in these appliances. These semiconductors produce electromagnetic waves due to faster switching. Accordingly, certain prerequisites have to be met for avoiding electromagnetic effects produced during switching .

Disturbances can occur in all the areas of the drive system and can get developed by :

- capacitive discharge currents. The reason is, high voltage gradients on connecting the semiconductors.
- high currents and high current gradients in the motor cables. The disturbance energy held in the magnetic fields attains frequencies of a few Hertz up to about 30 MHz. Additional electromagnetic fields with frequencies up to about 600 MHz are produced by the high voltage units.
- high cycle rates and fast logic circuits (electromagnetic field/16 MHz to 1GHz).

6.5.1 EMC regulation (EMVG)

This appliance complies with the § Sec. 6, Cl. 9 of the EMC act dated 18.09.1998:

"Within the meaning of Para 3, the apparatuses, systems and structural parts, which are manufactured and meant exclusively as parts or spare parts for further processing by industries or persons having expertise in the field of electromagnetic compatibility , do not have to comply with the requirements relating to protection as also those stated in §Sec.4, Para 1 No. 1 to 3 and 5 ."

The EMC depends largely upon the assembly of the respective structural groups and components in the control cabinet. The directions given in the pages that follow are meant to enable the user to design the system based on the latest EMC-know -how, thus complying with the statutory regulations in this regard.

6.5.2 Measures for compliance with the EMC

The design directions given below should be taken into consideration without fail for compliance with the EMC .

6.5.2.1 Cables

- shield **all** the connected cables so that they are free from disturbing radiations (see [►Shielding◄](#) from page 57). The control cables may be fitted without shielding, if the control cabinet has a sufficiently high shield damping (see limiting values for radio disturbance emission in accordance with the EMC Act for your system) and furthermore, when the EMC -compatibility inside the control cabinet is guaranteed (this can be assumed to be so when you have adhered to all the design directions given in this documentation).

6.5 Requirements for laying the cables (EMC instructions)

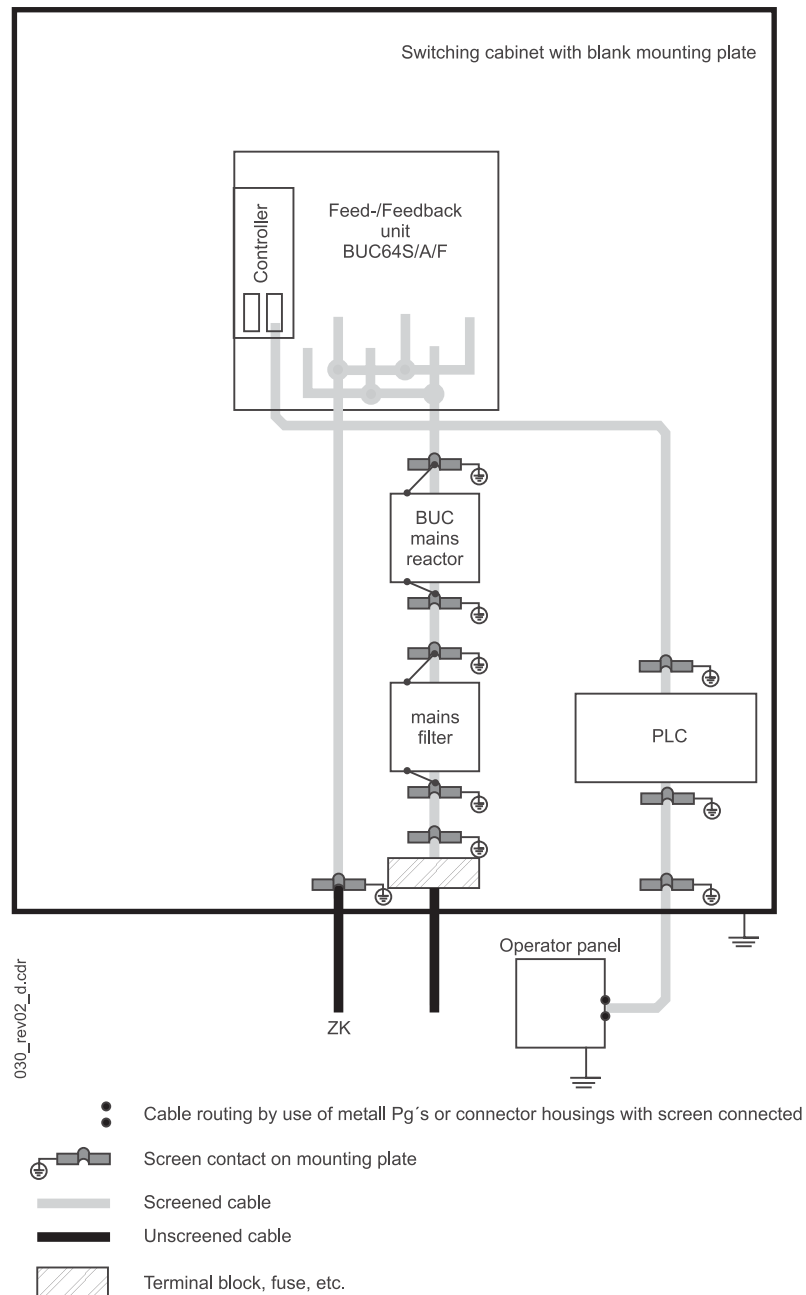

Figure 19: Suggested cable connections for BUC64S/A/F

- The cable (DC link circuit connection) between the BUC and the appliances connected on the BUS must consist of one single piece. Do not interrupt the cable by, say terminals, contactors, fuses, etc.
- The cable (DC link circuit connection) between the BUC and the appliances connected on the BUS should be as short as possible.

- lay the cables directly on the earth provided by the metallic appliance carrier for obtaining the smallest possible effective height of the antenna .

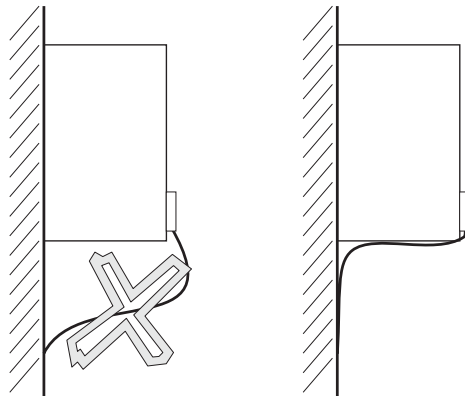

Figure 20: Reducing effective height of the antenna

- in principle, lay all the cables as near as possible to the conductors of the earthing system for reducing the effective loop area for magnetic coupling .

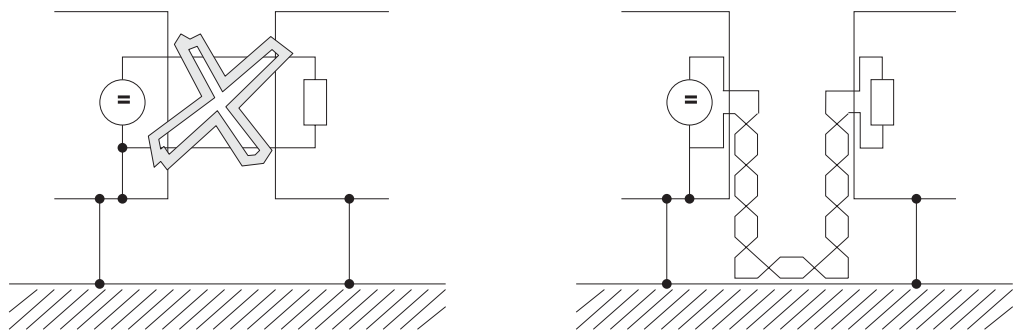

Figure 21: Reducing the loop areas

- a minimum spacing of 20 cm must be maintained between the conductors, where signal-/control cables and power cables are laid parallel to each other.
- cross the cables belonging to different EMC -categories only at an angle of 90 °.
- twist the conductors of every pair of the cores with each other, and the pair of the cores amongst each other in case of symmetrical signal - transmission (e.g. difference amplifier inputs for the specified RPM).
- establish the shortest possible joint/connection between the earthing connection : rectifier and the earthing plate (< 30 cm). Use large cross sections (>10 mm²).
- maintain a spacing of not less than 20 cm between the rectifier, its wiring and
 - disturbances like contactors, transformers, chokes, etc. and
 - structural groups sensitive to disturbances.
- avoid reserve loops.
- always earth the reserve cores in the cables at both the ends (for providing additional shielding effect, avoiding hazardous static charge voltages which are coupled with a capacitance).
- use a separate mains filter for every appliance. If disturbance in all the drives is to be eliminated together - do not interrupt any of the shields between the rectifier and the motor.

6.5 Requirements for laying the cables (EMC instructions)

6.5.2.2 Earthing

Classical earthing in star - form is not adequate any more from EMC -considerations for avoiding the effect of HF - disturbances. Large sized reference surface giving better results has to be connected with the earth of the appliances (e.g. bright metallic mounting plate and body parts).

- ▶ run all the earthing conductors and the shields close across the earthing for avoiding earth loopings.
- ▶ connect the regulator reference potential and the earth by using a cable having largest possible cross sectional area and shortest possible length (< 30 cm), where it is possible to earth the regulator reference potential of the unit.
- ▶ remove the insulation coatings like paint, lacquer, adhesive, etc. from the earthing connections.
- ▶ if required, use washers (DIN 6798) or adopt similar measures for ensuring a permanent contact having good conducting property.
- ▶ select suitable metal pairings (electrochemical voltage series) for preventing the possibility of corrosion of earthing connections.
- ▶ keep the conducting electrolyte away from the connection by provision of a protective coat (e.g. grease).
- ▶ connect the shields at both the ends with a good large conducting surface with the earth.
This is the only way for suppressing the effect of magnetic or HF disturbing fields.
- ▶ lay the receiver side as galvanic, and the transmitter as capacitive, if there are any problems with the earthing loops (e.g. double earthing of the -shield with conductor of set value) .
- ▶ connect the exterior cable shields with the wall, when the cable has to pass through the walls separating different EMC -areas from each other..

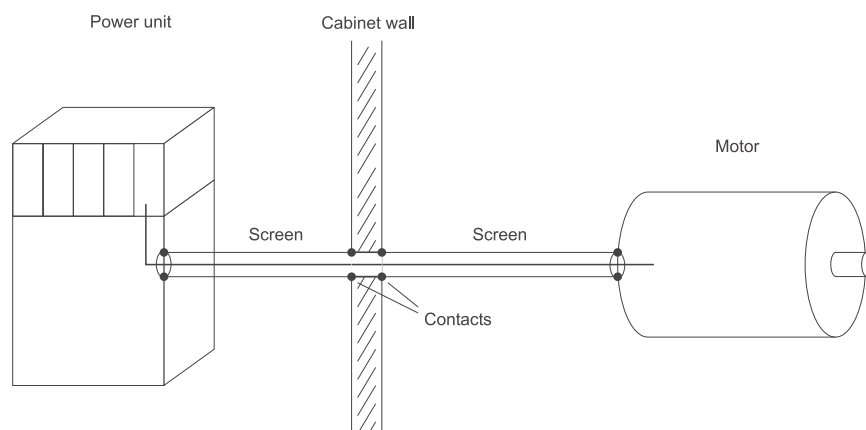

Figure 22: cable connection where they pass through the cabinet wall

cables passing through the walls of the shielding bodies without taking special precautions (e.g. filtering), may impair/reduce the shielding effect of these bodies.

- ▶ accordingly, connect the cable shields with good conducting properties even at the point where they come out of the shield wall.

- ▶ see to it that the distance between the last shield contact point and the exit point from the cabinet is as short as possible..

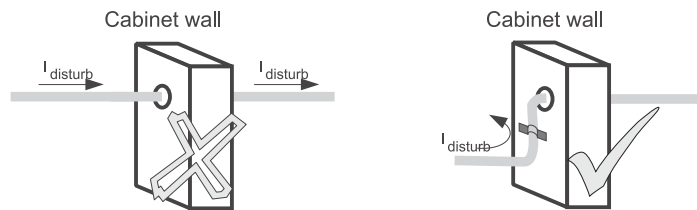

Figure 23: cable shielding at the point of exit from the cabinet

6.5.2.3 Shielding

The shield is effective against magnetic and electrical fields, if both its ends are earthed. Shielding effect against electrical fields is obtained even when the shield is earth only on one side.

- ▶ if there exist HF fields, then lay the shield always at both the ends (regardless of the length of the cable), be it an electrical or a magnetic field..

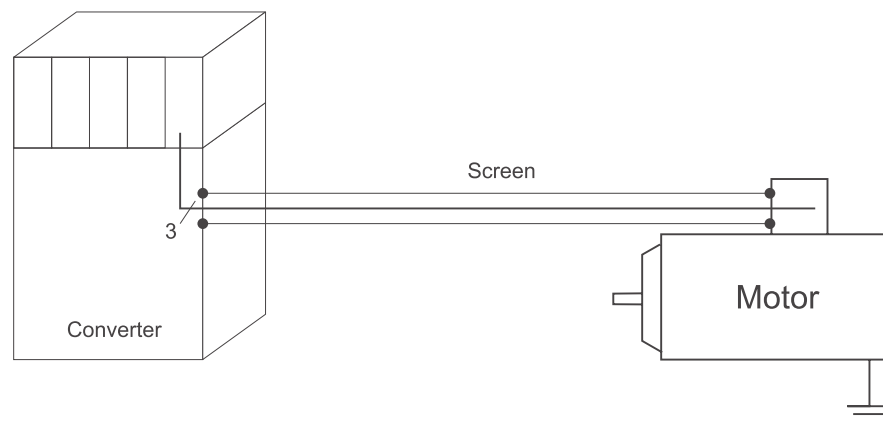

Figure 24: Shielding on both the sides

Shielding of the system (motor/rectifier) is not broken if the shield is earthed on both the sides.

Earthing the cable shields on both the sides still does not fully eliminate the effect of earthing loops. These effects are however extremely rare, if the directions given in the paras ([▶Cables](#) from page 53) and ([▶Earthing](#) from page 56) are followed.

HF-connection of a shield to earth can as well be made by using a capacitance . This prevents LF - disturbances caused by the earthing loops.

- ▶ do not separate the shielded cables crossing different EMC-areas at the terminals, since otherwise this reduces the shielding effect sharply.
- ▶ if possible, take the cables to the next structural group/subassy. without break.
- ▶ design all the shield connections with large surface area and low impedance .

cable ends having a length of just 3 cm (1 cm wire = 10 nH) reduce the shielding effect in the event of any disturbance in the MHz-range by about 30 dB.

6.5 Requirements for laying the cables (EMC instructions)



NOTE

The shield braiding must have a covering of not less than 85%.

The cables mentioned below have a special disturbing potential:

- Motor cables
- cables for external ballast resistances
- cables laid between the mains filter and the rectifier

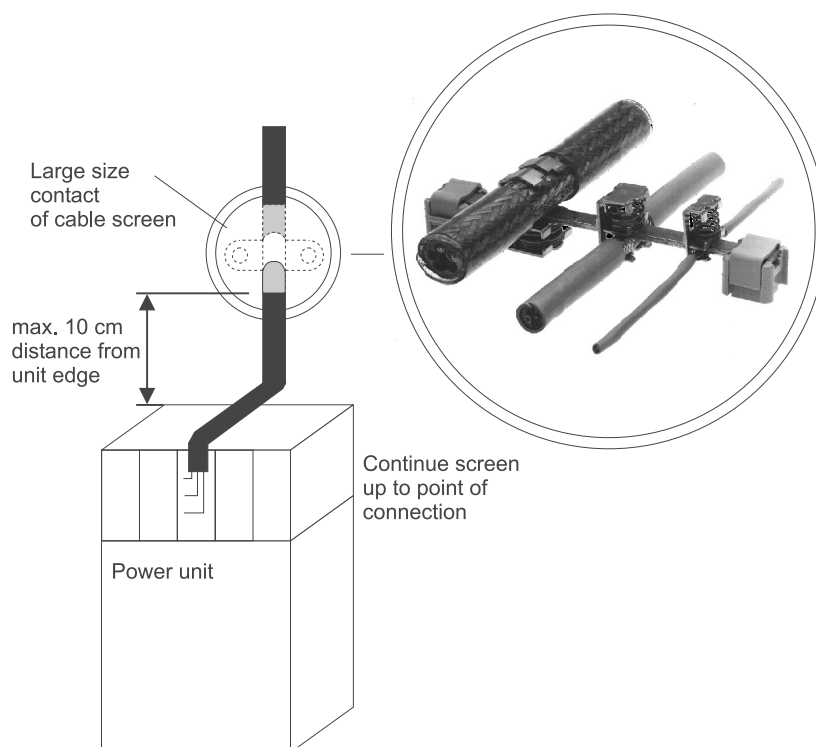

Figure 25: Suggestion for tying the shield

Shield terminals available from Baumüller Nürnberg GmbH can be found in ([▶B.1 EMC-accessories◀](#) on page 85).

6.5.2.4 Leakage currents

Parasite capacitance in the power unit, motor cable and motor winding give rise to leakage currents of the order of 100 mA and higher, depending upon the governing principle.

It follows from this, that rectifier could be incompatible with FI-protective switches !

- pay attention to and observe the safety instruction in this regard, given in Cl. 5.2.11.2 of EN 50178/VDE 0160.

6.6 Connection diagram

- lay the cables, taking the EMC into consideration and then connect them as indicated in the connection diagram.



WARNING

The following **may occur**, if you do not observe this warning information:

- serious personal injury
- death



*The hazard is: **electricity**.*

See to it that the permissible connected power-value is never exceeded (see [▶Power unit - electrical data](#)◀ from page 96 onwards) !

Mount the covers supplied along with once again and tighten the covers by the fixing screws after having connected the cables to the power terminals.

Further additional information can be found in [▶Block circuit diagrams](#)◀ from page 29 onwards and [▶Connection diagram BUC64S/A/F, with ballast](#)◀ on page 60.

6.6 Connection diagram

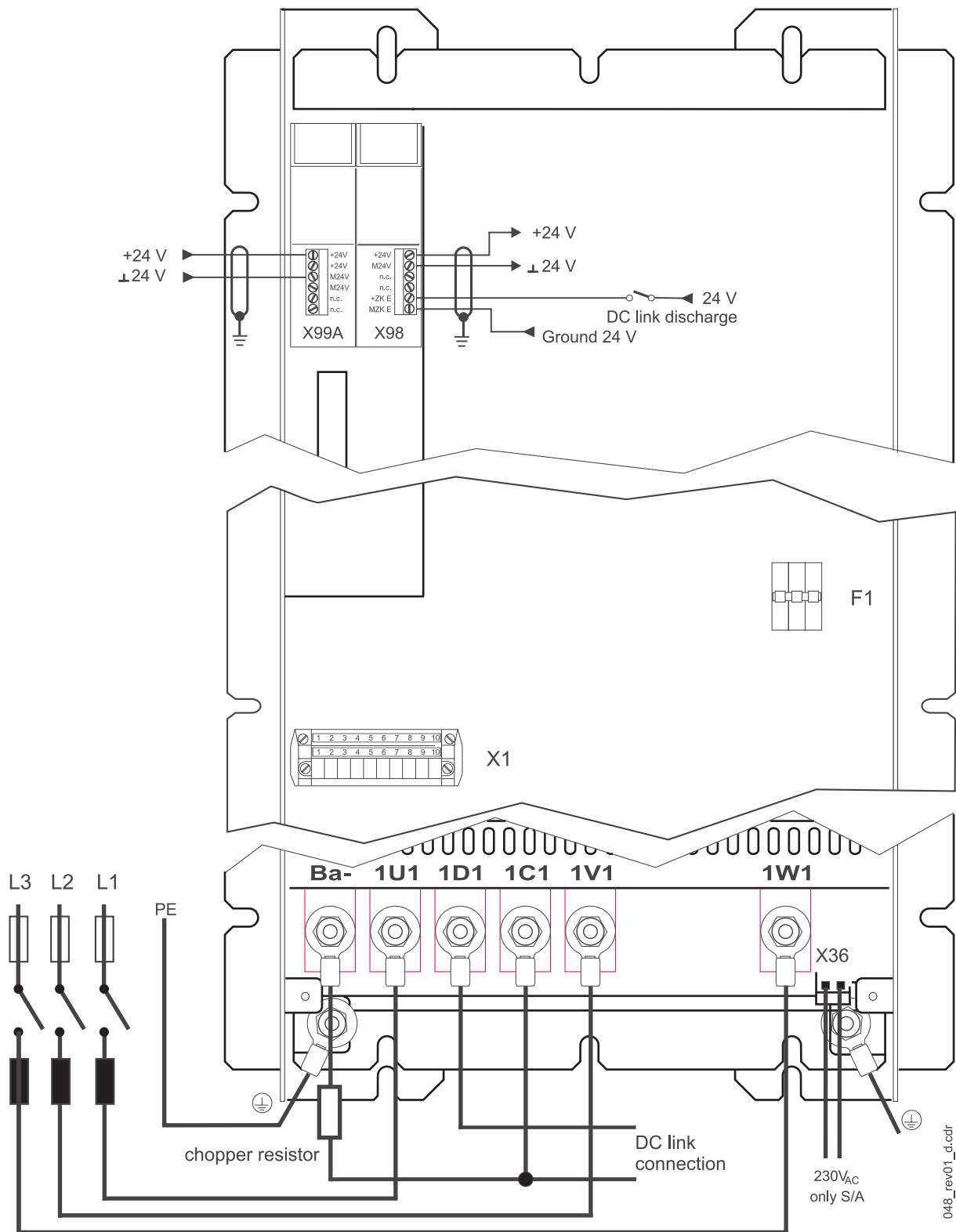

Figure 26: Connection diagram BUC64S/A/F, with ballast

Information on the respective terminals can be found in the section [▶Power terminals◀](#) from page 48 onwards.

Further additional directions for connections are given below .

+ 24 V ⊥ 24V	24 V voltage supply with safe isolation/(cutoff) (PELV) as per Table7, IEC 61131-2, for supplying to the Electronic Part
-----------------	--

7

COMMISSIONING

The commissioning exists of the following steps:

- 1 Check mounting
- 2 Check installation
- 3 Check safety appliances
- 4 Switch on device

Further information concerning the single steps are to be found in the following sections.

7.1 Requirements to the executing personnel



WARNING

The following **may occur**, if you do not observe this warning information:

- serious personal injury
- death



The hazard is: electricity. At the operation of this device inevitably certain parts of this device are under perilous voltage.

Assure that exclusively qualified personnel who is familiar with the safety instructions as well as with the mounting-, operating and maintenance instructions works at this device.

Qualified personnel are persons, who were given the permission by the responsible person for this system to execute the required actions and thereby are able to recognize and avoid possible hazards due to their education, experience, introduction as well as knowledge about standards and regulations, accident prevention regulations and operating environments. Qualifications for the work at this device are for example:

- Education or introduction or the permission to set in operation, to earth and to label current circuits and devices according to the standards of the safety techniques.
- Education or introduction according to the standards of safety technique in maintaining and using of an appropriate safety equipment.

7.2 Check mounting

- ▶ assure that the device is correctly screwed to the switching cabinet.
- ▶ assure that the seal is not damaged
(only valid for through-hole variant A/F).
- ▶ assure that the cooling circuit is dense (only valid for the variant F).

7.3 Checking the installation



WARNING

The following **may occur**, if you do not observe this warning information:

- serious personal injury
- death

The hazard is: electricity. The components under voltage must be protected against direct touching.

This is achieved by insulation, type of construction, position, arrangement or firmly mounted installations.

The power connections of the power module is non-isolated!

Essential for the protection for personal protection are the protective measures and the safety instruction according to DIN/VDE. At missing protective earth connections at the device or at the motor personal injury must be expected, because on the surface perilous voltages can appear.

The protective earth connection is to be executed according to DIN EN 60204/VDE 0113 part 1; para. 8.2.2 under consideration of EN 50178/VDE 0160, para. 5.3.2.1 and 8.3.4.4.

In the power module as well as in the motor always leakage currents appear during operation., that are withdrawn over the specified protective earth connections and can lead to a premature access to a connected ELCB.

In case of a fault to frame or of an earth fault a DC component can arise in the error current, which complicates or avoids the tripping of a higher-level ELCB.

Also at a dropping of the main contactor of the supplying device the parts of the power module are under perilous voltage.

- ▶ check, if the cables to the power connection are laid correctly and are correctly connected.
- ▶ check if the cables to the signal connections are correctly laid and are correctly connected.

7.4 Checking of the safety appliances



WARNING

The following **may occur**, if you do not observe this warning information:

- serious personal injury
- death

This device is under perilous voltage and contains dangerous rotating machine parts (a fan at device type A/S).

Switching cabinets must have an emergency button, with which all voltages, which can result in dangers, can be switched off. Not included are operating means, where due to its switching off, a new danger can arise. The trigger for the emergency device has to be applied in such a way, that it can be reached quickly in case of danger. At workings, which are associated with a considerably higher danger, the presence of a further person is necessary.

- ▶ check, before switching on the drive, all higher level safety appliances according to their function, in order to exclude a risk of personnel injury.
- ▶ assure, before commissioning, that the covers have been applied over the components under voltage and that the fan is covered by appropriate lattices.
- ▶ assure, that the protection against accidental contact has been executed according to §4 Abs. 4 VBG 4.

7.5 Switch on the device



WARNING

The following **may occur**, if you do not observe this warning information:

- serious personal injury
- death

During first commissioning an incorrect or uncontrolled movement of the driven machine elements can not be excluded. Therefore during the first commissioning place considerable significance on being carefully.

Special caution is advisable at the direct or indirect touching of the driving shaft (manually). This is only permitted at standstill of shaft and with a disconnected power module. Freely placed machine parts (shafts, fans, or similar) must be covered during operation.

If an error occurs the drive is switched current-free, subsequently the motor coasts to standstill. This circumstance is especially to be considered with travel drives and with lift drives.

- ▶ assure, that there are no persons in the danger area of the driven machine.
- ▶ assure, that the installation can be switched off over an emergency stop device.
- ▶ switch on the device in the specified starting sequence (see ▶ [Starting sequence](#) ◀ from page 66) and refer to incorrect or uncontrolled statuses of the installation.

7.5.1 Starting sequence

Take care that the automatic circuit breaker F1 in the BUC 64 is switched on. If the automatic circuit breaker F1 is not switched on, the DC link cannot be pre-charged.

- 1 Switch on automatic circuit breaker
- 2 Switch-in electronic supply (+24 V an X99A:1/3)
- 3 Internal loading contactor starts up as soon as the terminals X1:4/5 - power ON/OFF - have been connected
- 4 Loading procedure begins with the switch-in of the supply feed of the the installation

After precharging of DC link has taken place the loading switch is turned off and the mains contactor over the device-internal contact at X1: 6/7 is switched on. Not until impulse release has taken place at X26:14, the DC link then is uploaded to the nominal voltage, which was set (P087 „Uzk-nom“). The isolated relay contact X26:12/13 „Ready for operation“ at the V-controller (see description 5.03047) is closed.

The setting of the nominal values and the parametrization of the DC link voltage control is to be executed at the V-controller (see description 5.03047).

8

OPERATION

Rather than the operation proper, the important aspects to be monitored and the indicating elements on the appliance are described in this chapter.

8.1 Safety instructions



WARNING

The following **may occur**, if you do not observe this warning information:

- serious personal injury
- death

Report immediately the changes that have occurred, which could have an adverse effect on safety.

Stop the system exactly as per the procedure laid down for the same, before dismantling the safety devices for commissioning or repairs.

Mount the safety devices again and make sure that they are functioning properly, immediately after completing the commissioning or repairs jobs.

At ambient temperatures in the range of 40 °C to 55 °C, the peak output power (peak power, DC link circuit) is bound to be reduced by 3% / °C . This can be achieved only by suitable parametrization of the connected axes.

The axes connected must be set such that the peak output power (peak power, DC link circuit) is attained in not take more than 120 Sec.

See V-controller, Operation Manual 5.95036.

8.2 Switching on

Switch on the appliance in the sequence specified (see [▶Starting sequence◀](#) on page 66).

8.3 Monitoring functions and „ready for operation“

These functions monitor the condition/status of the appliance. They govern the superposed message : „ready for operation“ (see ▶Figure 27◀ on page 68).

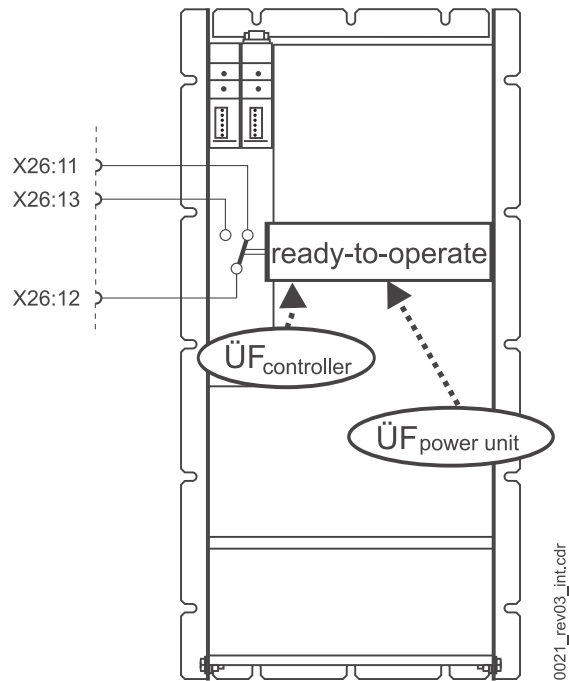

Figure 27: Monitoring functions and „ready for operation“



NOTE

The monitoring functions are active, only when a supply voltage of +24V is present at X99A .

8.4 Monitoring functions

The table below gives a list of the monitoring functions.

Monitoring function		V-controller	Reset
Power pack	Overcurrent	F 0202 ¹⁾	controller 2)
	Earthing current (short circuit)	F 0203 ¹⁾	controller 2)
	Overvoltage, DC link	F 0201 ¹⁾	controller 2)
	Overtemperature, heat sink	F 0205 ¹⁾	controller 2)
	internal auxiliary voltage	F 0204 ¹⁾	controller 2)
controller	see <i>V-controller Manual 5.03047</i>	F xxxx ¹⁾	controller 2)

¹⁾ This and other messages are displayed on the V-controller display and in the Parameter P124 „M error code“ - see V-controller Manual 5.03047).

²⁾ The messages can be erased only by pressing reset on the controller.
The display and deletion of the messages are described in the documentation of the controller.

8.4.1 Monitoring functions, power unit

The „Monitoring functions, power unit“ govern the message: „Ready for operation“.

The following aspects can be monitored in the power unit:

Overcurrent

Each one of the 3 mains phase currents is monitored.
If the phase current exceeds the peak value of the peak current by 30 %, then the BUC generates this message. It is stored in the power unit and passed on to the controller.



NOTE

Overcurrent monitoring does not protect the appliance from damage/destruction. **Except in the event of a short circuit in the DC link circuit**, the peak current of the mains phase currents is restricted by regulating it to the permissible value for avoiding getting the message „Overcurrent“. Securing the mains connection by semiconductor fuses is thus imperative ([▶Figure 4◀](#) on page 29, fuse F3)

8.4 Monitoring functions

Earthing current (short circuit) Monitoring the mains connection for proper earthing.
The message is generated, when the fault current exceeds 20 % of the permissible peak current of the power unit. This message is passed on to the controller.

Overvoltage, DC link circuit The magnitude of the voltage of the DC link circuit is monitored.
This message is generated, when the DC link circuit voltage attains a value of 840 V, and passed on to the controller.



NOTE

This message can occur, when, on braking, a drive unit supplies a power higher than the maximum feedback power permissible for the appliance (BUC). This fault can also occur due to the parameters of the controller not being optimum.

Overtemperature heat sink Monitoring the temperature of the heat sink.
There is a temperature sensor on the heat sink, the value measured by which is passed on further to the controller.



CAUTION

The following **may occur**, if you do not observe this caution information:

- property damage.

*The hazard is: **temperature of the appliance too high**. The maximum permissible temperature of the heat sink is of the order of 90 °C - the appliance can get destroyed at temperatures higher than this.*

internal aux. voltage Monitoring the supply voltage for the control circuits of the power transistors.
This message is generated in the event of failure of the internal auxiliary voltage and passed on to the controller.

8.4.2 Monitoring functions of the controller

Besides the monitoring functions specific to the power unit, additional monitoring functions concerning only the controller are available; see V-controller, Operation Manual 5.03047.

8.5 Ready for operation



NOTE

The appliance gets ready for operation after about 5 seconds after applying the supply voltage of +24V and switching on the mains .

The message: ready for operation in respect of the voltage controller contains both the monitoring functions:

1. Monitoring function of the power unit
2. Monitoring function of the controller

Relay

The relay „Ready for operation“ in the V-controller closes the potential free message contact X26:12/13, if **no** monitor has responded (see V-controller, Operation Manual 5.03047.)

8.6 Discharging of the DC link circuit/ballast control

Discharging of the DC link circuit The ballast transistor is switched on regardless of the magnitude of the DC link voltage and without getting interlocked by the V-controller, when a control voltage of 24V is applied at the terminals X98:5/6 . Care must be taken to see that the switching on is controlled only with the V-controller blocked and the mains - contactor switched off.

Ballast control Independent of the contact „Discharging of the DC link circuit“ X98:5/6, the ballast is switched on automatically above an DC link voltage higher than 815V. As soon as the DC link voltage drops below 795V, the ballast is switched off.

MAINTENANCE

9.1 Service intervals

The required flow rate of the cooling air cannot be achieved any more, if the surrounding air is polluted, whereby the dust depositions clog the ventilation holes (applicable in respect of the design execution

A/S of the appliance).

However, even before that, such dust depositions prevent taking away the heat from the appliance at the required rate. Dust depositions on the ventilation holes are a warning signal and attention must be paid to this.

- ▶ Check the instruments fitted on the control cabinet which ensure that the required ambient conditions are satisfied (e. g. air filter) and maintain these, where required, as per the details provided by the manufacturer.
- ▶ Check every week, the specified ambient conditions.

The specified ambient conditions can be found [▶ Appendix D - Technical Data◀](#) from page 93 onwards.

- ▶ Check every month, the mixing proportion of the corrosion protective agent (applicable only for the through plugging variant F)

REPAIR



DANGER

The following **will occur**, if you do not observe this danger information:

- serious personal injury
- death

Only the Baumüller personnel entrusted with the safety instructions as also those relating to mounting, operation and maintenance are authorized to repair this appliance.

This appliance carries hazardous amount of voltage - accordingly, all the repairs activities must be carried out only when the voltage from the appliance has been cut off.

Work on the DC link circuit must not be started before ensuring that neither any potential nor any voltage (residual charge) are present.

The machine must be stopped exactly as per the specifications therefore before dismantling the safety devices for commissioning or for repairs. These must be mounted again and checked for proper function after completion of commissioning or repairs jobs.



NOTE

The user of the machine must carry out an acceptance check on the entire drive unit and record the same in chronological order in the form of a report (maintenance ledger) after every stoppage (and repairs/changes) of the drive, be it of the motor, measuring instrument/gauge or the power module.

The user shall be liable for the legal consequences if this procedure is not followed.



SHUTDOWN, STORAGE

Shutdown of BUC64S/A/F and its subsequent storage are described in this chapter.

11.1 Requirements of the personnel carrying out the shutdown

The personnel entrusted with the job of shutdown must be in possession of the knowledge and instruction necessary for carrying out the activities related to this in a proper manner. The personnel have to be selected such that they are in a position to understand and apply the appropriate safety instructions relating to the appliance and its parts as also the connections.

11.2 Safety instructions

The safety instructions applicable for commissioning must also be applied to shutdown with the relevant changes, where required.



DANGER

The following **will occur**, if you do not observe this danger information:

- serious personal injury
- death

*The danger is : **electricity***

Make sure that power from all the electrical terminals is disconnected and they are secured against getting switched on inadvertently.

*The structural elements in the appliance (e. g. condensers) may be containing hazardous amount of charge ! The condensers used in the appliance will get discharge automatically, earliest **10 min.** after switching off the supply voltage.*

By using suitable measuring instruments, check before working at the electrical terminals that they are not carrying any voltage, and do not dismantle them until having convinced yourselves about their being free from any voltage.

11.3 Shutdown

This consists of the following steps :

- 1 connect free from voltage and secure against getting switched on inadvertently.
- 2 check all the terminals for their being free from voltage (about 10 min. after switching off).
- 3 dismantle the terminals and keep them secure as per the safety instructions.
- 4 (eventually: dismantle and close the cooling circuit lines).
- 5 document the shutdown.

11.4 Dismantling

The prerequisite for dismantling is completion of shutdown with documentation of the procedure followed.

Regulations and the safety instructions, the same as those for “ Mounting ” have to be followed for dismantling. Please note here that BUC64S/A/F weighs about 65kg and about 88kg; accordingly make provision for suitable equipment for transportation (lifting gear, crane, transportation personnel, etc.) after dismantling.

Loosen all the mechanical connections with the control cabinet only after having secured the appliance against its falling down or falling out.

Keep suitable packing material ready if you want to store the appliances; in case of doubt, ask Baumüller Nürnberg GmbH During transportation, see to it that the appliance will not get damaged due to faulty storage or heavy impacts/bumps. Also see [►Packing and Transportation◄](#) from page 23 onwards.

11.5 Storage conditions

The shelf life is without any limit, if the following storage conditions are maintained :

- Climatic Class: 1 K 4
- Temperature range: - 30 °C bis + 70 °C

11.6 Maintenance during storage

No maintenance whatsoever is required during storage.

11.7 Recommissioning

- 1 Sealing strips have to be replaced for the through plugging variant A/F. see [►Guidelines for mounting of BUC64 through plugging variant A/F◄](#) on page 42
- 2 Carry out commissioning as in case of a new appliance (see chapters 5 to 8).

12

DISPOSAL

The correct and safe way of disposal of BUC64 S/A/F-appliances is described in this chapter. The disposal mainly produces scrap in the form of (ferrous and nonferrous) metals, plastics and electronic scrap.

12.1 Safety instructions

The disposal must be carried out with due regards and by paying attention to the safety instructions. Where required, also observe and pay attention to the local regulations, if any. If you are not able to carry out disposal by yourself, entrust it to a suitable disposal agency.

CAUTION



The following **may occur**, if you do not observe this danger information:

- environmental pollution.



*The danger is: **improper disposal***

In the event of fire, hazardous materials may eventually be evolved or liberated.

Do not expose the electronic structural elements not to high temperatures.

Beryllium oxide is used as internal insulation, for instance for different power - semiconductors. The beryllium dust evolved on opening is hazardous to health.

Do not open the electronic structural elements .

12.2 Requirements of the personnel entrusted with carrying the disposal

The personnel entrusted with the job of disposal/dismantling must be in possession of the knowledge and instruction necessary for carrying out the activities related to this in a proper manner. The personnel have to be selected such that they are in a position to understand and apply the appropriate safety instructions relating to the appliance and its parts.

12.3 Disposal instructions

- Prerequisites**
- The appliance has been dismantled properly as per the laid down procedure.
 - All the tools and accessories required for dismantling are kept ready and are in technically sound working condition.

12.3.1 Subassemblies

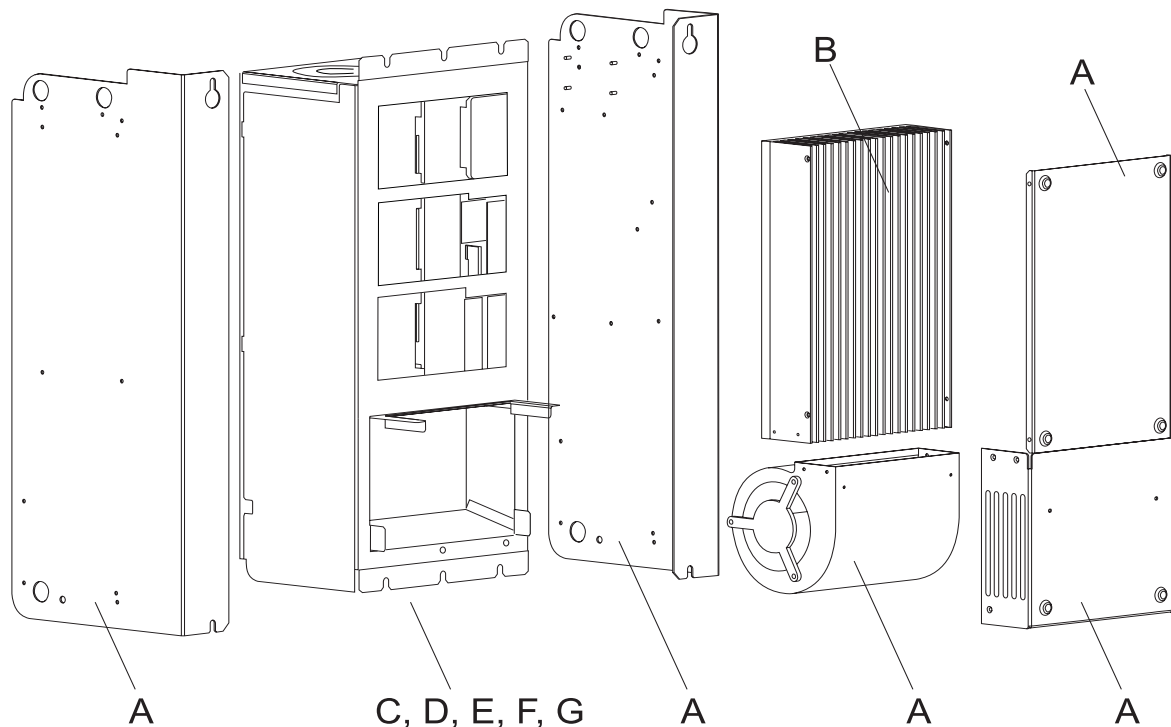

Figure 28: Diagram showing dismantling

The structural parts/groups indicated in round brackets can be found in the drawing.

- Steel plate** (A) Steel plate(s) must be supplied to the material circulation channel for ferrous metals.
- Aluminium** (B) Aluminium must be supplied to the material circulation channel for nonferrous metals.
- Aluminium/copper-compound** (C) Aluminium/copper-compound must be supplied to the material circulation channel for nonferrous metals.
- Plastics** (D) The plastic parts of the body as well as the covers/panels and other such small parts made of plastic must be supplied to the material circulation channel for plastic materials.

**CAUTION**

The following **may occur**, if you do not observe this danger information:

- environmental pollution.

*The hazard is: **improper disposal***

Dispose off the following structural parts/groups as special garbage.

Condensors	(E) Dispose off the condensors as special garbage. Pay attention to and observe the appropriate Regulations hereby.
Semiconductor modules	(F) Dispose off the semiconductor modules as special garbage. Pay attention to and observe the appropriate Regulations hereby.
Electronic scrap	(G) The electronic scrap consisting of conductor plates which cannot be dismantled must be sent for recycling, as special scrap. Pay attention to and observe the appropriate Regulations hereby.

12.4 Disposal agencies/authorities

See to it that the disposal jobs are carried out in conformity with the guidelines laid down by your company for the same, as also by the disposal agencies and authorities. In case of doubt, the industrial supervisor competent for your company or the pollution control authority.



APPENDIX A - ABBREVIATIONS

Abs.	Par.	SL	Protective Conductor
AC	Alternating Current	TBA	Overtemperature, chopper resistor
BB	Ready for Operation	U_{ZK}	DC link voltage
BBext	Readiness for Operation (external)	VBG	Association of Administrative Professionals
BBint	Readiness for Operation (internal)	VDE	Association of German Electro-technical Professionals
BSA	Reference potential, analog	X	Terminal Strip
BSD	Reference potential, digital	ZK	DC link circuit
BSE	Reference external for 24 V-control input (parameters)		
BUC	Baumüller Feed-/Feedback-Unit		
BUS	Baumüller Power -Module		
DC	Direct Current		
DIN	German Institute for Standardization		
EMC	Electromagnetic Compatibility		
EN	European Norm		
EXT, ext	External		
FI	Fault/(Leakage) Current		
HE	Main Contactor, ON		
HS	Main Contactor		
HSE	Main Contactor, On		
HSF	Main Contactor, Realize		
LED	Light Emitting Diode		
M24	Reference potential, 24 V		
mtr.	Medium inertia		
PELV	Protective small voltage with safe isolation, earthed		
R	Reserved		
SE	Shield Earth		
SELV	Protective small voltage with safe isolation		



APPENDIX B - ACCESSORIES

B.1 EMC-accessories

Shield terminals for earthing			
<p>Cable-Ø 2 x 2 - 6 mm</p> <p>Article-No. 226 752</p>		<p>Cable-Ø 3 - 8 mm</p> <p>Article-No. 226 741</p>	
<p>Cable-Ø 4 - 13,5 mm</p> <p>Article-No. 226 745</p>		<p>Cable-Ø 10 - 20 mm</p> <p>Article-No. 226 749</p>	

B.2 Plug

Article	Article-no.	Manufacturer - ordering no. / Type
Plug for X99A	00309455	Phoenix Contact - MVSTBW 2,5/6-ST
Plug for X98	00309454	Phoenix Contact - MVSTBR 2,5/6-ST
Plug for X1	00362559	Phoenix Contact - PC 4/7-STF-7,62

B.2.1 Semiconductor fuses (F3, ▶Figure 4◀ on page 29)

SITOR	1	450A/1000V: 3NE3 233	aR	Size1	110 mm
SITOR	2	450A/1000V: 3NE3 333	aR	Size 2	110 mm

Size _____▲



NOTE

The fuses are not suitable for separating the load.

B.3 Mains-chokes

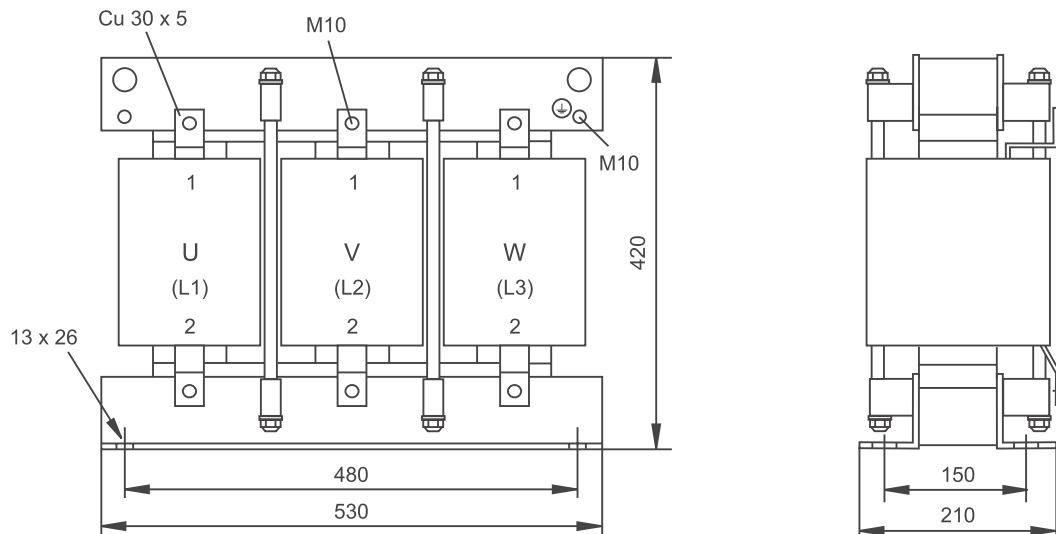

Rated current: 300 Aeff
Rated voltage: 3 x 400 Veff - 460 Veff ± 10%
Frequency: 50/60 Hz
Inductance: 3 x 0,4 mH
Total loss: 1 kW

Degree of protection: IP 00

Weight: 120 kg

Article no.: 00363544

B.4 Water cooling

Sealing strip : Article-No. 00350790

Connecting sockets : Contact Baumüller Nürnberg GmbH.



APPENDIX C - DECLARATION OF CONFORMITY/MANUFACTURER

In this section we provide general information about EU directives, the CE symbol and the Declaration of Conformity/by Manufacturer.

C.1 What is an EU directive?

EU directives specify requirements. The directives are written by the relevant bodies within the EU and are implemented by all the member countries of the EU in national law. In this way the EU directives guarantee free trade within the EU.

An EU directive only contains essential minimum requirements. You will find detailed requirements in standards, to which references are made in the directive.

C.2 What the CE symbol indicates

a) The CE marking symbolizes conformity to all the obligations incumbent on manufacturers for the product by virtue of the Community directives providing for its affixing.

...

b) The CE marking affixed to industrial products symbolizes the fact that the natural or legal person having affixed or been responsible for the affixing of the said marking has verified that the product conforms to all the Community total harmonization provisions which apply to it and has been the subject of the appropriate conformity evaluation procedures.

...

Council Decision 93/465/EEC, Annex I B. a) + c)

We affix the CE mark to the equipment and to the documentation as soon as we have established that we have satisfied the requirements of the relevant directives.

All converters and control systems supplied by the Baumüller Nürnberg GmbH satisfy the requirements of 73/23/EEC (Low Voltage Directive).

As all converters and control systems comply with the requirements of the harmonized standards EN50178, EN 60204-1, EN 60529 and HD625.1 S1, the protection targets of 73/23/EWG are reached.

With specified application of this Baumüller equipment in your machinery, you can act on the assumption that the equipment satisfies the requirements of 98/37/EG (machinery directive). Therefore the equipment is developed and constructed in such a way, that the requirements of the harmonized standard EN 60204-1 can be met by the electrical installation.

Compliance with 89/336/EEC (EMC Directive) depends on how the equipment is installed. Since you are performing installation yourself, it is you who are responsible for complying with 89/336/EEC.

A declaration of conformity on the EMC directive therefore cannot be issued.

We will provide you with support in the form of EMC information. You will find this information in the operating manual and in “filters for main applications”. When you have complied with all the requirements we impose in this documentation, you can assume that the drive satisfies the requirements of the EMC Directive.

The limit values and requirements for variable-speed electrical drives are determined in the harmonized product standard EN61800-3. If you are erecting an installation, for which a declaration of conformity on the EMC directive must be generated, it may be necessary to specify several harmonized standards, which you have used for the compliance of the protection targets of the directive. The harmonized product standard EN 61800-3 has to be used with electrical drives.

To enable you to market your machine within the EU, you must be in possession of the following:

- Conformity mark (CE mark)
- Declaration(s) of Conformity regarding the directive(s) relevant to the machine

C.3 Definition of the term Declaration of Conformity

A Declaration of Conformity as defined by this documentation is a declaration that the electrical equipment brought into circulation conforms to all the relevant fundamental safety and health requirements.

By issuing the Declaration of Conformity in this section the Baumüller Nürnberg GmbH declares that the equipment conforms to the relevant fundamental safety and health requirements resulting from the directives and standards which are listed in the Declaration of Conformity.

C.4 Definition of the term Declaration by Manufacturer

A Declaration by Manufacturer as defined by this documentation is a declaration that the machine/safety component brought into circulation conforms to all the relevant fundamental safety and health requirements.

By issuing the Declaration of Conformity in this section the Baumüller Nürnberg GmbH declares that the equipment conforms to the relevant fundamental safety and health requirements resulting from the directives and standards which are listed in the Declaration of Conformity .

The Baumüller equipment is integrated into a machine. For health and safety, of the users for example, it is important for the entire machine to conform to all the relevant fundamental safety and health requirements. For this reason the Baumüller Nürnberg GmbH draws attention in the Declaration by Manufacturer to the fact that it is prohibited to put the machine as a whole into operation before it has been declared that the machine conforms to the provisions of the Machinery Directive.

C.5 Declaration of Conformity

EU-Konformitätserklärung

Declaration of Conformity

gemäß EU-Richtlinie 73/23/EG (Niederspannung) vom 19.02.1973

geändert durch: 93/68/EWG vom 22.07.1993

in accordance with EC directive 73/23/EG (low voltage) dated 19.02.1973

changed by: 93/68/EWG dated 22.07.1993

BUC64S/A/F BUC64X - XXX/XXX - XX - X - X - XXX

Das obige Gerät wurde entwickelt und konstruiert sowie anschließend gefertigt in Übereinstimmung mit o.g. EU-Richtlinie und u.g. Normen in alleiniger Verantwortung von:

the unit specified above was developed and constructed as well as manufactured in accordance with the above mentioned directive and the standards mentioned below under liability of:

Baumüller Nürnberg GmbH, Ostendstr. 80 - 90, D-90482 Nürnberg

Berücksichtigte Normen - standards complied with:

Norm / standard

EN 50178	Ausrüstung von Starkstromanlagen mit elektrischen Betriebsmitteln Electronic equipment for use in power installations
EN 60204-1	Sicherheit von Maschinen - Elektrische Ausrüstung von Maschinen Safety of machinery - Electrical equipment of machines
EN 60529	Schutzarten durch Gehäuse (IP Code) Degrees of protection provided by enclosures (IP Code)
HD 625.1 51	Isulationskoordination für elektrische Betriebsmittel in Niederspannungsanlagen Insulation coordination for equipment within low-voltage systems

Nürnberg, 15.03.2005

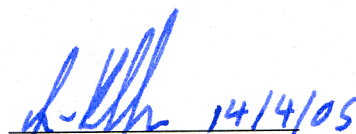

Andreas Baumüller
Geschäftsführer
Head Division



ppa. Dr. Peter Heidrich
Entwicklungsleiter
Head of development

C.6 Declaration by Manufacturer

EU-Herstellererklärung

Declaration by Manufacturer

gemäß EU-Richtlinie 98/37/EG (Maschinen) vom 22.06.1998

geändert durch: 98/79/EG vom 27.10.1998

in accordance with EC directive 98/37/EG (machinery) dated 22.06.1998

changed by: 98/79/EC dated 27.10.1998

BUC64S/A/F BUC64X - XXX/XXX - XX - X - X - XXX

Die Inbetriebnahme der Maschine, in die dieses Gerät eingebaut wird, ist untersagt bis die Konformität der Maschine mit der genannten Richtlinie erklärt ist.

The machinery into which this unit is to be incorporated must not be put into service until the machinery has been declared in conformity with the provisions of the directive mentioned.

Bei der Entwicklung und Konstruktion des Gerätes wurden folgende Normen beachtet:

The development and construction of the unit is complied with following standards:

Norm / standard

EN 60204-1	Sicherheit von Maschinen - Elektrische Ausrüstung von Maschinen Safety of machinery - Electrical equipment of machines
------------	---

Baumüller Nürnberg GmbH, Ostendstr. 80 - 90, D- 90482 Nürnberg

Nürnberg, 15.03.2005

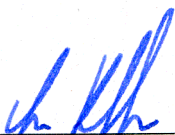
14/4/05
Andreas Baumüller
Geschäftsführer
Head Division

12.4.2005
ppa. Dr. Peter Heidrich
Entwicklungsleiter
Head of development



APPENDIX D - TECHNICAL DATA

This appendix gives an overview of the technical data. Some of these data has been used in the earlier chapters at appropriate places.

D.1 Requirements of the power supply

Control voltage ¹⁾ (U_{DC})	+ 24 V -10 % / +20 % ²⁾
--	------------------------------------

¹⁾ The supply voltage must conform to PELV (EN 50178, chapt. 3.49) or SELV (EN 50178, Cl. 3.70).

²⁾ EN6 1131-2:1994, table 7

D.2 Immunity level of burst

Signal interfaces	1 kV
Power interfaces	2 kV

D.3 Required ambient conditions

D.3 Required ambient conditions

Temperature range for transportation	- 30 °C bis + 70 °C
Climatic class for transportation	2 K 3 ¹⁾
Temperature range for storage	- 30 °C bis + 70 °C
Climatic class for storage	1 K 4 ¹⁾
Operation surrounding	outside residential areas ²⁾
Temperature range for operation	min. 0 °C bis max. 55 °C ³⁾
Climatic class for operation	3 K 3 ¹⁾
Height of installation ⁴⁾	up to 1000 m above MSL (rated operation)
Relative humidity (operation)	5 % to 85 % without dewing ¹⁾
Ionizing and nonionizing radiation	no restrictions
Vibration, shock and repetitive shock	max. 1 g ⁵⁾
Degree of pollution	2 ⁶⁾
Temperature of the cooling air ⁸⁾	min. 0 °C up to max. 55 °C ³⁾
Temperature of the cooling water ⁷⁾	min. „temp.of the cooling air ⁹⁾ “ up to max. 60 °C
Cooling air through the appliance (without heat sink)	300 m ³ / h
Cooling air through the heat sink	800 m ³ / h
Rate of flow of the cooling water ⁷⁾	min. 4 l/min. up to max. 10 l/min.
Pressure of the cooling water ⁷⁾	max. 6 bar
Temperature difference (cooling water inlet to its outlet)	4K at 4 l/min for normal operation
Pressure drop at the water cooler ^{7) 10)}	1,15 bar at 4 l/min

¹⁾ EN 50178, tab. 7

²⁾ HF-disturbances have to be reckoned with when used in residential areas (EN 61800-3, 6.4.2.1)

³⁾ 40° is the rated temperature; at higher ambient temperatures, the starting/initial power has to be reduced by 3% / °C. This can be achieved only by parametrizing the connected axes correspondingly.

⁴⁾ Characteristic curve: starting capacity of the appliance at the place of installation at normal air pressure

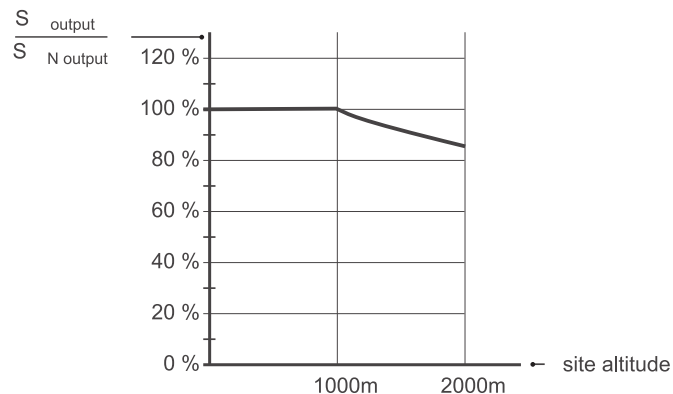

⁵⁾ EN 50178, Cl.. 9.4.3.2

⁶⁾ EN 50178, Tab. 2

- 7) Use clear, unpolluted desalinated and demineralized water free from suspended matter as the cooling medium. The water must not contain more than 100 ppm (0,01%) Sodium chloride (Salt content). Add a corrosion preventing agent thereto. The overall hardness of the water must be of the order of 8° to 14° dH (1° dH = 0,179 mmol Ca²⁺/l). The pH-value must be maintained between 6,5 and 7,5 Use a closed cooling system !
- 8) Air inside and outside the control cabinet.
- 9) Air inside the control cabinet.
- 10)

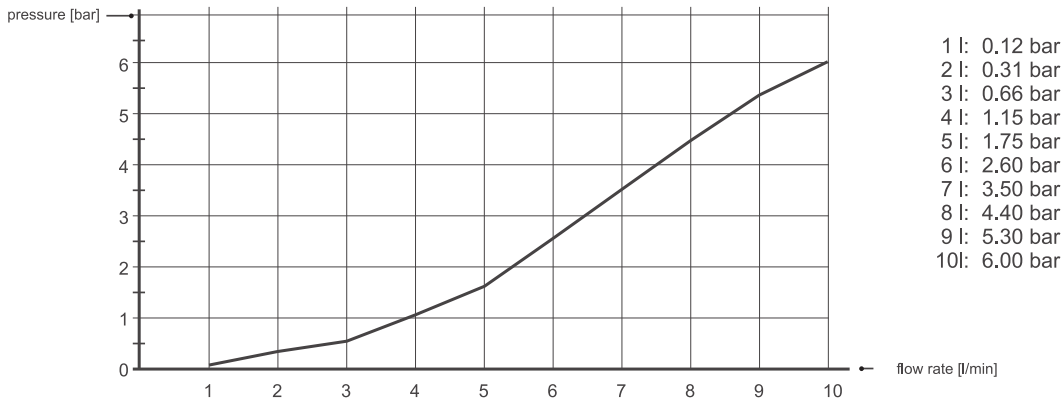

D.4 Power unit - electrical data

	BUC64S/A/F
Supply network	Industrial network with hard or low impedance earthed star point (TN-network or TT-network)
Mains voltage	3 x 400 V _{AC} - 460 V _{AC} ±10 %
Mains frequency	47Hz ... 63Hz
Mains voltage -unsymmetry	max. 3% ⁸⁾
Voltage breaks, depth of break	< 40 %, area < 250 % x degree ⁹⁾
Harmonic vibrations	THD < 10% ⁷⁾
Input - rated current ¹⁾³⁾⁴⁾ (I _{AC_N})	300A _{AC} at 4 kHz ²⁾
Input-peak current ¹⁾³⁾⁵⁾ (I _{AC_max})	390A _{AC} at 4 kHz ²⁾
Connected power, DC link circuit P _{zk_{out}_N} (1C1 / 1D1) ¹⁰⁾	205kW at 4 kHz ²⁾
Peak power, DC link circuit P _{zk_{out}_max} (1C1 / 1D1) ¹¹⁾	267kW at 4 kHz ²⁾
Input - rated current ¹⁾³⁾⁴⁾ (I _{AC_N})	230A _{AC} at 8 kHz ²⁾
Input-peak current ¹⁾³⁾⁵⁾ (I _{AC_max})	300A _{AC} at 8 kHz ²⁾
Connected power, DC link circuit P _{zk_{out}_N} (1C1 / 1D1) ¹⁰⁾	155kW at 8 kHz ²⁾
Peak power, DC link circuit P _{zk_{out}_max} (1C1 / 1D1) ¹¹⁾	205kW at 8 kHz ²⁾
DC link voltage ¹⁾	640V _{DC} ... 760 V _{DC}
DC link circuit capacitance (internal)	6000 μF/900 V
Max. DC link circuit capacitance (external)	12000 μF/900 V
Power losses, power unit ¹⁾	3000 W
Power losses, inside the appliance (with controller, without fan)	250 W
Input - rated current 24 V	2,5A
Control voltage of the charging contactor	24 V _{DC} (supplied internally)
Control voltage of the main contactor	230 V _{AC} , max. 1 A _{AC}
Connected voltage, fan ⁶⁾	230 V _{AC} +5 % -10 % 50/60 Hz
Fan power ⁶⁾	max. 200 W

¹⁾ All the rated values are based on the mains voltage of 400 V_{AC} and a switching (on/off) frequency of 4 kHz.

²⁾ Switching (on/off) frequency of the inverter. In this context, see the Operation Manual of the controller.

³⁾ Effective/(RMS) - value at an ambient temperature of 40 °C.

⁴⁾ The starting power (peak power, DC link circuit) has to be reduced by 3% / °C between 40° C and 55°C. See description of the BUS-axes.

⁵⁾ The connected axes must be set such that the starting power (peak power, DC link circuit) is not required for longer than 120 sec. See description of the BUS-axes.

⁶⁾ applicable only for the cooling variants S and A.

⁷⁾ EN 61800-3, Cl. 5.2.1, Class 3

⁸⁾ IEC 1000-2-4, tab. 1, class 3

⁹⁾ EN 61800-3, Cl. 5.2.2

10) $P_{zk_{out_N}} = P_{1N} - \Delta P_{Network\ choke} - \Delta P_{Switching\ losses}$, with $P_{1N} = \sqrt{3} \times U_{1N} \times I_{AC_N}$ and $U_{1N} = 400V_{AC}$.

With the DC link circuit connected power $P_{zk_{out_N}}$ permitted continuously, the mains current I_{AC_N} at a mains voltage of for instance, $460V_{AC}$ becomes smaller by the ratio $400/460 = 0,87$ (instead of $300A_{AC}$, the mains current is then of the order of $260A_{AC}$). While selecting the axes (BUS-appliances) care must be taken to see that $P_{zk_{out_N}}$ is not exceeded.

11) $P_{zk_{out_max}} = P_{1max} - \Delta P_{Network\ choke} - \Delta P_{Switching\ losses}$, with $P_{1max} = \sqrt{3} \times U_{1N} \times I_{AC_max}$ and $U_{1N} = 400V_{AC}$.

This drawing of power is allowed only for a short duration (max. 120 sec.). This must be ensured by parametrizing the connected axes (BUS-appliances) correspondingly (see Operation Manual for the BUS-appliances).

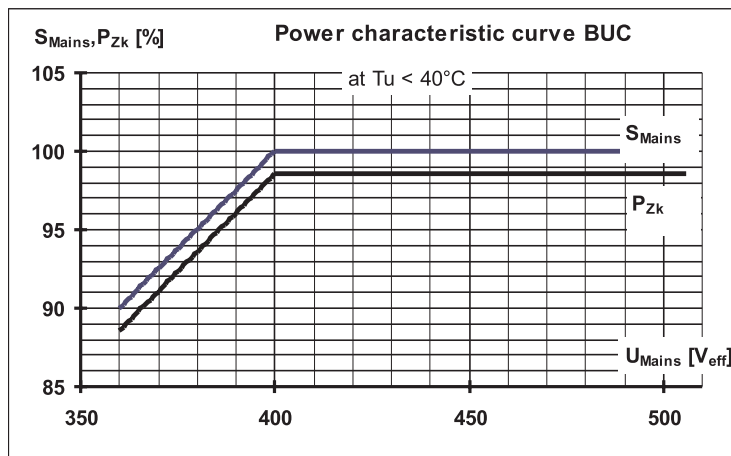

045_rev01_d.cdr

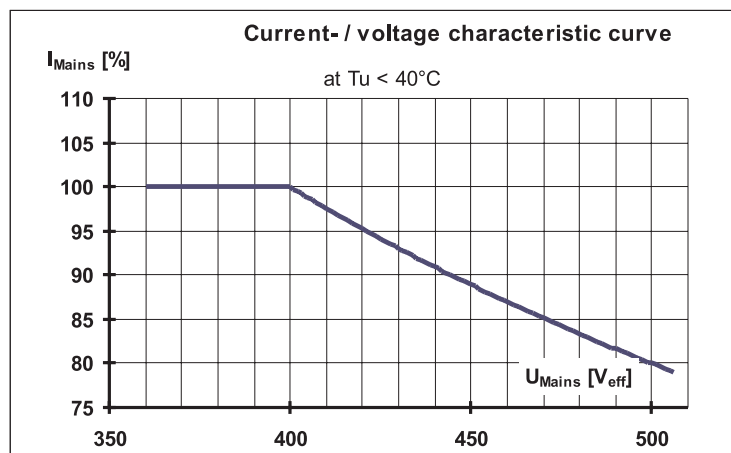

046_rev01_d.cdr

D.5 Electrical data - chopper resistor

D.5 Electrical data - chopper resistor

max. chopper resistor current ¹⁾	130A _{DC}
Chopper resistor, internal	absent
min. chopper resistor, external	8 Ω
Voltage threshold, chopper resistor ON	815V _{DC}
Voltage threshold, chopper resistor OFFS	795V _{DC}

¹⁾ The chopper resistor connection is not short circuit - proof ! Take the min. chopper resistor into consideration !

D.6 BUC64S - nonelectrical data

Dimensions (B x H x T)	448 x 920 x 304 mm
Weight without controller	about 88 kg
Type of protection	IP 00
Fire extinguishant	ABC-powder

D.7 BUC64A - nonelectrical data

Dimensions (B x H x T)	490 x 885 x (244+90) mm ¹⁾
Weight without controller	about 80 kg
Type of protection	IP 00/outside IP 44
Fire extinguishant	ABC-powder

¹⁾ The first value is the breadth inside the control cabinet while the second one is the breadth outside the control cabinet.

D.8 BUC64F - nonelectrical data

Dimensions (B x H x T)	490 x 885 x (244+30) ¹⁾ mm
Weight without controller	about 65 kg
Type of protection	IP 00/outside IP 54
Fire extinguishant	ABC-powder

¹⁾ The first value is the breadth inside the control cabinet while the second one is the breadth outside the control cabinet.

D.9 Cable : control voltage supply/ signals

Cross section	0.2 to 2.5 mm ² (without core end sheath) 0.25 to 2.5 mm ² (with core end sheath) (AWG 24 to 12)
max. length	any
Ferrule, connected to the appliance	flexible, with or without ferrule

D.10 Cable : power connection

Cross section ¹⁾	depends upon the connection
Type of cable	shielded, shield covering > 85 % after the mains filter
Cable shoe/ferrule, connected to the appliance ²⁾	Cable shoe

1) EN 60204-1, tab. 5, mode of laying C.

2)

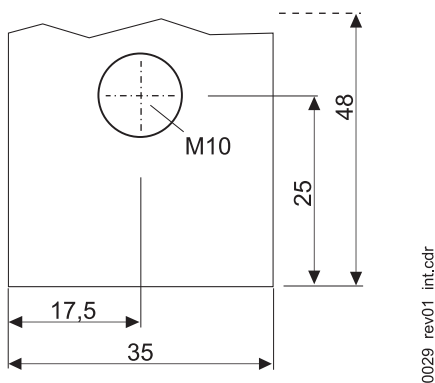

A maximum of 2 cable shoes can be connected on one plate. Do not fit the cable shoes above each other, mount only one cable shoe per side.
Use cable shoes having a maximum breadth of 35 mm.



Table of figures

Cooling variants	26
Hazard areas.....	27
Identification plate with Type key	28
Block circuit diagram BUC64S/A/F	29
Connection : BUC - BUS.....	30
Construction drawing BUC64-300A/390A Part 1	31
Construction drawing BUC64-300A/390A Part 2	32
Suggestion for controlling Power On/Off.....	33
Hazard areas during mounting.....	35
Dimensioned diagram BUC64S/A/F.....	37
Drilling Diagram/Pattern BUC64S/A/F	38
Guidelines for mounting of BUC64S	40
Guidelines for mounting of BUC64 through plugging variant A/F	42
Hazard prone areas	47
Power terminals	48
Control Terminal X99A.....	50
Control Terminal X98	51
isolated optocoupler input	51
Suggested cable connections for BUC64S/A/F	54
Reducing effective height of the antenna.....	55
Reducing the loop areas	55
cable connection where they pass through the cabinet wall	56
cable shielding at the point of exit from the cabinet	57
Shielding on both the sides	57
Suggestion for tying the shield	58
Connection diagram BUC64S/A/F, with ballast.....	60
Monitoring functions and „ready for operation“	68
Diagram showing dismantling	80



Table of figures



Index

Numbers

73/23/EWG 89

A

Abbreviations 83

Ambient temperature 94

B

Baumüller 23

C

Cable

EMC instructions 53

laying 53

Cabling 53

Connection

DC-link 96

Control Cabinet

thickness of the rear panel 36

Control voltage 93

D

DC link voltage

maximum 49

E

Earthing 56

EMC instructions 53

F

First steps 7

H

Harmonic vibrations 96

Height of installation 94

L

Leakage currents 58

Low Voltage Directive 89

M

max. DC link voltage 49

Maximum temperature 70

O

Overtemperature 70

P

Personnel

qualified 20

Power loss 96

Q

Qualified Personnel 20

R

reconstruction 8, 20

S

Shield Terminals 85

Shielding 57

Skilled labour 20

T

Terms used 7

Thickness of the rear panel

maximum 36

U

Unsymmetry 96

V

Voltage breaks 96

Voltage threshold 98



Index

be in motion

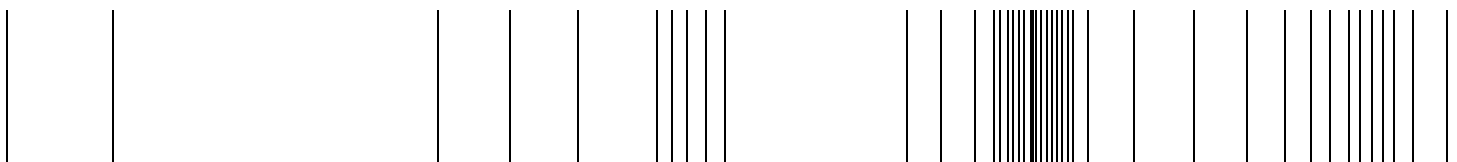

Baumüller Nürnberg GmbH Ostendstraße 80-90 90482 Nürnberg T: +49(0)911-5432-0 F: +49(0)911-5432-130 www.baumueller.de

All information given in this manual is customer information, subject to change without notice. We reserve the right to further develop and actualize our products continuously using our permanent revision service. Please notice, that specifications/data/information are current values according to the printing date. These statements are not legally binding according to the measurement, computation and calculations. Before you make any information given in this manual to the basis of your own calculations and/or applications, please make sure that you have the latest edition of the information in hand. No liability can be accepted concerning the correctness of the information.