

be in motion be in motion

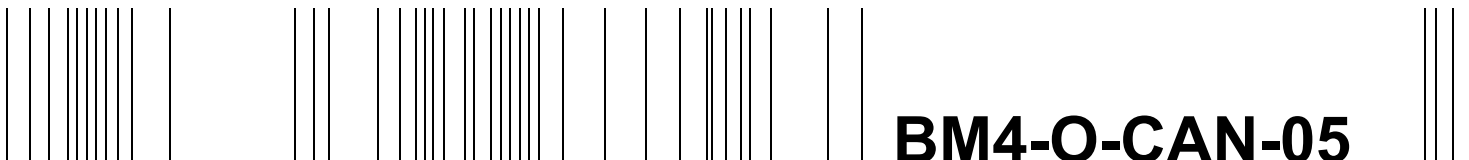

BM4-O-CAN-05

**Option Module CANsync-
Slave for b maXX
Operating Instructions**

E

5.02064.02



Title	Operating Instructions
Product	Option Module CANsync-Slave for b maXX BM4-O-CAN-05
Last Revision	April 15, 2003
Copyright	<p>Owners may make as many copies as they like of these Operating Instructions exclusively for their own internal use. You are not allowed to copy or duplicate even extracts from these Operating Instructions for any other purposes. You are not permitted to exploit or communicate the contents of these Operating Instructions.</p> <p>Any other designations or company logos used in these Operating Instructions may be trademarks whose use by third parties for their own purposes may affect the rights of the owner of the trademark.</p>
Binding nature	<p>These Operating Instructions are a part of the unit/machine. These Operating Instructions must always be available to operators and be legible. If the unit/machine is sold, the owner must pass on these Operating Instructions together with the unit/machine.</p> <p>After selling the unit/machine you must pass on this original and all the copies that you made to the purchaser. After disposing of the machine in any way, you must destroy this original and all the copies that you made.</p> <p>When you pass on these Operating Instructions, all earlier revisions of the corresponding Operating Instructions are invalidated.</p> <p>Note that all the data/numbers/information that are quoted are current values at the time of printing. This information is not legally binding for dimensioning, calculation and costing.</p> <p>Within the scope of further-development of our products, Baumüller Nürnberg Electronic GmbH & Co. KG reserve the right to change their technical data and handling.</p> <p>We cannot guarantee these Operating Instructions are completely error-free unless this is expressly indicated in our General Conditions of Business and Delivery.</p>
Manufacturer	Baumüller Nürnberg Electronic GmbH & Co. KG Ostendstr. 80 - 90 90482 Nuremberg Germany Tel. +49 9 11 54 32 - 0 Fax: +49 9 11 54 32 - 1 30 www.baumueller.de



Hiermit zeigen wir an, dass die Baumüller Nürnberg Electronic GmbH & Co. KG im Wege der Verschmelzung mit Wirkung zum 01.12.2004 in der Baumüller Nürnberg GmbH aufgegangen ist. Ihr zukünftiger Ansprechpartner ist damit die

Baumüller Nürnberg GmbH, Ostendstrasse 80-90, 90482 Nürnberg.

Please notify that with effect from 01-12-2004 Baumüller Nürnberg Electronic GmbH & Co. KG merged with Baumüller Nürnberg GmbH. Your future business partner will be

Baumüller Nürnberg GmbH, Ostendstrasse 80-90, 90482 Nürnberg.

Par la présente, nous vous signalons qu'en voie de la fusion, la Baumüller Nürnberg Electronic GmbH & Co. KG a été intégrée à la Baumüller Nürnberg GmbH avec effet au 1 décembre 2004. Votre interlocuteur sera par conséquent la

Baumüller Nürnberg GmbH, Ostendstrasse 80 – 90, 90482 Nürnberg.





1	Introduction	5
1.1	First Steps	5
1.2	Terms Used	5
2	Basic Safety Instructions	7
2.1	Hazard information and instructions	7
2.1.1	Structure of hazard information	8
2.1.2	Hazard advisories that are used	9
2.2	Information signs	11
2.3	Legal information	11
2.4	Appropriate Use	11
2.5	Inappropriate Use	12
2.6	Protective equipment	12
2.7	Personnel training	13
2.8	Safety measures in normal operation	13
2.9	Responsibility and liability	13
2.9.1	Observing the hazard information and safety instructions	13
2.9.2	Danger arising from using this module	14
2.9.3	Warranty and Liability	14
3	Packaging and transportation	15
3.1	Transportation	15
3.2	Unpacking	15
3.3	Disposing of the packaging	16
3.4	Observe during transportation	16
4	Description of the CANsync-Slave option module	17
4.1	Structure	17
4.1.1	DIP switches	17
4.1.2	Slot for CANsync-Slave option module BM4-O-CAN-05	20
4.2	Danger zones	20
4.3	Marking of the CANsync-Slave option module type code	21
5	Assembly and installation	23
5.1	General safety regulations	23
5.2	Requirements of the personnel carrying out work	24
5.3	Preparation	24
5.4	Assembly	25
5.5	Installation	29
5.5.1	Connection diagram	29
5.5.2	Requirements of electrical connection	29
5.5.3	Requirements of the connection cable	30
5.5.4	Sequence of installation	30
6	Commissioning	31
6.1	General safety regulations	31
6.2	Requirements of the personnel carrying out work	31
6.3	Description/inspection of the safety and monitoring systems	32
6.4	Description and inspection of the controls and displays	32
6.4.1	Sample Configuration	32
6.4.2	LEDs	32
6.5	Commissioning sequence	35
6.5.1	Detecting the CANsync-Slave option module for b maXX PLC	35
6.5.2	Testing the function of the CANsync-Slave option module for b maXX PLC	36
6.5.3	Detecting the CANsync-Slave option module for b maXX controller	36



TABLE OF CONTENTS

6.5.4	Testing the function of the CANsync-Slave option module for b maXX controller . . .	36
7	Operation	37
7.1	Operating the CANsync-Slave option module for b maXX PLC	37
7.2	Operating the CANsync-Slave option module for b maXX controller	37
7.2.1	Settings on the CANsync-Slave option module	39
7.2.2	Settings on WinBASS II page "synchronization"	40
7.2.3	Settings on WinBASS II page "BACI":	41
7.2.4	Settings on WinBASS II page "option modules G, H – configuration":	42
7.2.5	Settings on WinBASS II page "drive management":	47
7.2.6	Settings on WinBASS II page "data record management":	48
8	Finding and eliminating disturbances	51
8.1	Safety regulations.	51
8.2	Requirements of the personnel carrying out work	51
8.3	Error messages responses to errors	52
8.3.1	CANsync-Slave option module for b maXX PLC	52
8.3.2	CANsync-Slave option module for b maXX controller	52
9	Maintenance	55
10	Overhaul	57
11	Dismantling, storage	59
11.1	Safety regulations.	59
11.2	Requirements of the personnel carrying out work	59
11.3	Dismantling.	60
11.4	Storage conditions	60
11.5	Recommissioning.	60
12	Disposal.	61
12.1	Safety regulations.	61
12.2	Requirements of the personnel carrying out work	62
12.3	Disposal guide	62
12.4	Disposal locations/official bodies	62
Anhang A - Abbreviations		63
Anhang B - Accessories		65
B.1	List of all accessories	65
Anhang C - Declaration of Conformity/Manufacturer Declaration		67
C.1	What is an EC directive?	67
C.2	What the CE symbol indicates	67
C.3	Definition of the term Declaration of Conformity	68
C.4	Definition of the term Declaration by Manufacturer	68
C.5	Declaration of Conformity	69
C.6	Manufacturer Declaration	70
Anhang D - Technical Data		71
D.1	Connection values.	71
D.2	Pin assignment of RJ45 female connectors X1 and X2	72

1

INTRODUCTION

These operating instructions are an important component of your b maXX 4400; this means that you must thoroughly read this document, not least to ensure your own safety.

In this chapter, we will describe the first steps that you should carry out after getting this module. We will define terms that are used in this documentation on a consistent basis and will inform you about the topics that you must consider when using this option module.

For more detailed information on operating and using the modules, refer to the documentation entitled "Operating Instructions b maXX 4400", "Application Manual b maXX 4400" and "Application Manual CANsync for b maXX".

1.1 First Steps

- 1 Check the shipment see [►Packaging and transportation ◀](#) from page 15 onward.
- 2 Pass on all the documentation that was supplied with the plug-in module to the appropriate departments in your company.
- 3 Deploy suitable personnel for assembly and commissioning.
- 4 Pass on these operating instructions to this personnel and ensure that they have read and understood the safety instructions and that they are following them.

1.2 Terms Used

In this documentation, we will also refer to Baumüller's "BM4-O-CAN-05" product as "option module", "plug-in module" or "CANsync-Slave module".

We will also refer to the "BM4-O-PLC-01" Baumüller product as "b maXX PLC" or "BM4-O-PLC" and we will also use the term "b maXX" for the "b maXX 4400 basic unit".

The controller in the basic unit is also referred to as the "b maXX controller".

For a list of the abbreviations that are used, refer to [►Abbreviations ◀](#) from page 63 onward.

BASIC SAFETY INSTRUCTIONS

We have designed and manufactured each Baumüller plug-in module in accordance with the strictest safety regulations. Despite this, working with the plug-in module can be dangerous for you.

In this chapter, we will describe the risks that can occur when working with a Baumüller plug-in module. Risks are illustrated by icons. All the symbols that are used in this documentation are listed and explained.

In this chapter, we cannot explain how you can protect yourself from specific risks in individual cases. This chapter contains only general protective measures. We will go into concrete protective measures in subsequent chapters directly after information about the individual risk.

2.1 Hazard information and instructions



WARNING

The following **may occur**, if you do not observe this warning information:

- serious personal injury
- death

The hazard information is showing you the hazards which can lead to injury or even to death.

Always observe the hazard information given in this documentation.

Hazards are always divided into three danger classifications. Each danger classification is identified by one of the following words:

DANGER

- Considerable damage to property
- Serious personal injury
- Death **will** occur

WARNING

- Considerable damage to property
- Serious personal injury
- Death **can** occur

2.1 Hazard information and instructions

CAUTION

- Damage to property
- Slight to medium personal injury **can** occur

2.1.1 Structure of hazard information

The following two examples show how hazard information is structured in principle. A triangle is used to warn you about danger to living things. If there is no triangle, the hazard information refers exclusively to damage to property.



A triangle indicates that there is danger to living things. The color of the border shows how severe the hazard is: the darker the color, the more severe the hazard is.



The icon in the rectangle represents the hazard. The color of the border shows how severe the hazard is: the darker the color, the more severe the hazard is.



The icon in the circle represents an instruction. Users must follow this instruction. (The circle is shown dashed, since an instruction is not available as an icon for each hazard advisory).



The circle shows that there is a risk of damage to property.



The icon in the rectangle represents the hazard. The color of the border shows how severe the hazard is: the darker the color, the more severe the hazard is. (The rectangle is shown dashed, since the danger is not represented as an icon with every hazard advisory)

The text next to the icons is structured as follows:

THE SIGNAL WORD IS HERE THAT SHOWS THE DEGREE OF RISK



Here we indicate whether one or more of the results below occurs if you do not observe this warning.

- Here, we describe the possible results. The worst result is always at the extreme right.

Here, we describe the hazard.

Here, we describe what you can do to avoid the hazard.

2.1.2 Hazard advisories that are used

If a signal word is preceded by one of the following danger signs:  or  or , the safety information refers to injury to people.

If a signal word is preceded by a round danger sign: , the safety information refers to damage to property.

2.1.2.1 Hazard advisories about injuries to people

To be able to differentiate visually, we use a separate border for each class of hazard information with the triangular and rectangular pictograms.

For danger classification **DANGER**, we use the  danger sign. The following hazard information of this danger classification is used in this documentation.

DANGER



The following **will occur**, if you do not observe this danger information:

- serious personal injury
- death

*Danger from: **electricity**. The hazard may be described in more detail here.*

Here, we describe what you can do to avoid the hazard.

DANGER



The following **will occur**, if you do not observe this danger information:

- serious personal injury
- death

*Danger from: **mechanical effects**. The hazard may be described in more detail here.*

Here, we describe what you can do to avoid the hazard.

For danger classification **WARNING**, we use the  danger sign. The following hazard information of this danger classification is used in this documentation.

WARNING



The following **may occur**, if you do not observe this warning information:

- serious personal injury
- death

*Danger from: **electricity**. The hazard may be described in more detail here.*

Here, we describe what you can do to avoid the hazard.

For danger classification **CAUTION**, we use the  danger sign. The following hazard information of this danger classification is used in this documentation.

2.1 Hazard information and instructions



CAUTION

The following **may occur**, if you do not observe this caution information:

- minor to medium personal injury.

*Danger from: **sharp edges**. The hazard may be described in more detail here.*

Here, we describe what you can do to avoid the hazard.



CAUTION

The following **may occur**, if you do not observe this danger information:

- environmental pollution.

*Danger from: **incorrect disposal**. The hazard may be described in more detail here.*

Here, we describe what you can do to avoid the hazard.



2.1.2.2 Hazard advisories about damage to property

If a signal word is preceded by a round danger sign: ⓘ, the safety information refers to damage to property.



CAUTION

The following **may occur**, if you do not observe this caution information:

- property damage.

*Danger from: **electrostatic discharge**. The hazard may be described in more detail here.*

Here, we describe what you can do to avoid the hazard.



2.1.2.3 Instruction signs that are used



carry safety gloves



carry safety shoes

2.2 Information signs



NOTE

This indicates particularly important information.

2.3 Legal information

This documentation is intended for technically qualified personnel that has been specially trained and is completely familiar with all warnings and maintenance measures.

The equipment is manufactured to the state of the art and is safe in operation. It can be put into operation and function without problems if you ensure that the information in the documentation is complied with.

Operators are responsible for carrying out servicing and commissioning in accordance with the safety regulations, applicable standards and any and all other relevant national or local regulations with regard to cable rating and protection, grounding, isolators, over-current protection, etc.

Operators are legally responsible for any damage that occurs during assembly or connection.

2.4 Appropriate Use

You must always use the plug-in module appropriately. Some important information is listed below. The information below should give you an idea of what is meant by appropriate use of the plug-in module. The information below has no claim to being complete; always observe all the information that is given in these operating instructions.

- You must only install the plug-in module in series b maXX 4400 units.
- Configure the application such that the plug-in module is always operating within its specifications.
- Ensure that only qualified personnel works with this plug-in module.
- Mount the plug-in module only in the specified slot/slots.
- Install the plug-in module as specified in this documentation.
- Ensure that connections always comply with the stipulated specifications.
- Operate the plug-in module only when it is in technically perfect condition.
- Always operate the plug-in module in an environment that is specified in the technical data.
- Always operate the plug-in module in a standard condition.
For safety reasons, you must not make any changes to the plug-in module.
- Observe all the information on this topic if you intend to store the plug-in module.

You will be using the plug-in module in an appropriate way if you observe all the comments and information in these operating instructions.

2.5 Inappropriate Use

Below, we will list some examples of inappropriate use. The information below should give you an idea of what is meant by inappropriate use of the plug-in module. We cannot, however, list all possible cases of inappropriate use here. Any and all applications in which you ignore the information in this documentation are inappropriate; particularly, in the following cases:

- You installed the plug-in module in units that are not Series b maXX 4400.
- You ignored information in these operating instructions.
- You did not use the plug-in module as intended.
- You handled the plug-in module as follows
 - you mounted it incorrectly,
 - you connected it incorrectly,
 - you commissioned it incorrectly,
 - you operated it incorrectly,
 - you allowed non-qualified or insufficiently qualified personnel to mount the module, commission it and operate it,
 - you overloaded it,
- You operated the module
 - with defective safety devices,
 - with incorrectly mounted guards or without guards at all,
 - with non-functional safety devices and guards
 - outside the specified environmental operating conditions
- You modified the plug-in module without written permission from Baumüller Nürnberg Electronic GmbH & Co. KG.
- You ignored the maintenance instructions in the component descriptions.
- You incorrectly combined the plug-in module with third-party products.
- You combined the drive system with faulty and/or incorrectly documented third-party products.
- Your self-written PLC software contains programming errors that lead to a malfunction.

Version 1.1 of Baumüller Nürnberg Electronic GmbH & Co. KG's General Conditions of Sale and Conditions of Delivery dated 2/15/02 or the respective latest version applies in all cases. These will have been available to you since the conclusion of the contract at the latest.

2.6 Protective equipment

In transit, the plug-in modules are protected by their packaging. Do not remove the plug-in module from its packaging until just before you intend to mount it.

The cover on the b maXX units' controller sections provides IP20 protection to the plug-in modules from dirt and damage due to static discharges from contact. This means that you must replace the cover after successfully mounting the plug-in module.

2.7 Personnel training



WARNING

The following **may occur**, if you do not observe this warning information:

- serious personal injury
- death

Only qualified personnel are allowed to mount, install, operate and maintain equipment made by Baumüller Nürnberg Electronic GmbH & Co. KG.

Qualified personnel (specialists) are defined as follows:

Qualified Personnel Electrical engineers and electricians of the customer or of third parties who are authorized by Baumüller Nürnberg Electronic GmbH & Co. KG and who have been trained in installing and commissioning Baumüller drive systems and who are authorized to commission, ground and mark circuits and equipment in accordance with recognized safety standards.

Qualified personnel has been trained or instructed in accordance with recognized safety standards in the care and use of appropriate safety equipment.

Requirements of the operating staff The drive system may only be operated by persons who have been trained and are authorized.

Only trained personnel are allowed to eliminate disturbances, carry out preventive maintenance, cleaning, maintenance and to replace parts. These persons must be familiar with the Operating Instructions and act in accordance with them.

Commissioning and instruction must only be carried out by qualified personnel.

2.8 Safety measures in normal operation

- ▶ At the unit's place of installation, observe the applicable safety regulations for the plant in which this unit is installed.
- ▶ Provide the unit with additional monitoring and protective equipment if the safety regulations demand this.
- ▶ Observe the safety measures for the unit in which the plug-in module is installed.

2.9 Responsibility and liability

To be able to work with this CANsync-Slave option module in accordance with the safety requirements, you must be familiar with and observe the hazard information and safety instructions in this documentation.

2.9.1 Observing the hazard information and safety instructions

In these operating instructions, we use visually consistent safety instructions that are intended to prevent injury to people or damage to property.



WARNING

The following **may occur**, if you do not observe this warning information:

- serious personal injury
- death

Any and all persons who work on and with Series b maXX units must always have available these Operating Instructions and must observe the instructions and information they contain – this applies in particular to the safety instructions.

Apart from this, any and all persons who work on this unit must be familiar with and observe all the rules and regulations that apply at the place of use.

2.9.2 Danger arising from using this module

The CANsync-Slave option module has been developed and manufactured to the state of the art and complies with applicable guidelines and standards. It is still possible that hazards can arise during use. For an overview of possible hazards, refer to the chapter entitled [▶Basic Safety Instructions](#) ◀ from page 7 onward and to [▶Figure3](#) on page 21. We will also warn you of acute hazards at the appropriate locations in this documentation.

2.9.3 Warranty and Liability

All the information in this documentation is non-binding customer information; it is subject to ongoing further development and is updated on a continuous basis by our permanent change management system.

Warranty and liability claims against Baumüller Nürnberg Electronic GmbH & Co. KG are excluded; this applies in particular if one or more of the causes listed in [▶Inappropriate Use](#) ◀ from page 12 onward or below caused the fault:

- Disaster due to the influence of foreign bodies or force majeure.

PACKAGING AND TRANSPORTATION

We package every Baumüller plug-in module before shipping such that it is highly unlikely that it will be damaged in transit.

3.1 Transportation

The plug-in modules are packed at the factory in accordance with the order.

- ▶ Avoid vibrations during transportation and hard jolts.(Max. 1 g).
- ▶ Avoid static discharges to the plug-in modules' electronic components.
- ▶ Do not remove the plug-in module from its protective packaging until just before you intend to mount it.

3.2 Unpacking

After receiving the plug-in module while it is still packaged:

- ▶ Check whether there is visible damage to the packaging!

If there is:

- ▶ Complain to the delivery company. Have your complaint confirmed in writing and immediately contact your nearest Baumüller Nürnberg Electronic GmbH & Co. KG subsidiary.

CAUTION



The following **may occur**, if you do not observe this caution information:

- property damage.



*Danger from: **electrostatic discharge**. If you touch the plug-in module, and especially its electronic components, and subject them to electrostatic discharges, the module can be damaged or even totally destroyed.*

When handling the plug-in module, always observe the regulations and information on handling electrostatically sensitive components.

3.3 Disposing of the packaging

If no damage is visible:

- Open the module's packaging.
- Check the scope of supply against the delivery note.

The scope of supply is:

- **BM4-O-CAN-05 (CANsync-Slave option module for b maXX)**
- these Operating Instructions including the declaration of conformity/manufacturer declaration
- return the module to its packaging for transportation.
- complain to your local Baumüller subsidiary if you find damage or if the delivery is not complete.

3.3 Disposing of the packaging

The packaging consists of cardboard and plastic.

- Observe local disposal regulations if you intend to dispose of the packaging.

3.4 Observe during transportation

The module was packaged at the manufacturer's plant for initial transportation. If you have to transport the module at a later date, please note the following points:

- Use the original packaging material
- or
- Use packaging that is suitable for electrostatic sensitive devices.

Ensure that the following conditions always apply during transportation:

- 2 K 3 (Climatic category)
- - 30 °C to + 70 °C (temperature range)
- Max. 1 g (Vibration, shock, repetitive shock)

DESCRIPTION OF THE CANSYNC-SLAVE OPTION MODULE

In this chapter, we will describe the Option Module CANSync-Slave for b maXX option module and explain the type code on the plug-in module.

4.1 Structure

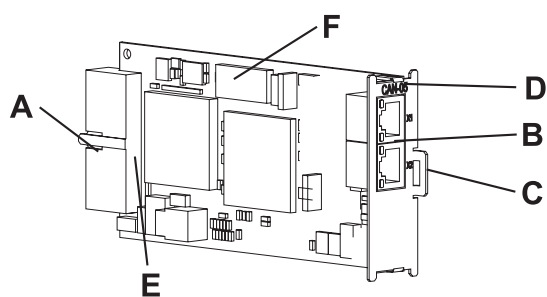

- A = Plug connector (back-mounted)
- B = Socket RJ45 (front)
- C = Grip
- D = Type code
- E = Serial number
- F = DIP switch

4000_sl22_rev01_int.cdr

4000_sl23_rev01_int.cdr

Figure 1: BM4-O-CAN-05 plug-in module

4.1.1 DIP switches

You configure the CANSync-Slave option module for b maXX PLC using DIP switches. When doing this, you make the following settings:

- CANSync slave number (DIP switches 4 to 8)
- Switching between CANSync-Slave for b maXX **PLC** and CANSync-Slave for b maXX **basic unit** (DIP switch 9)

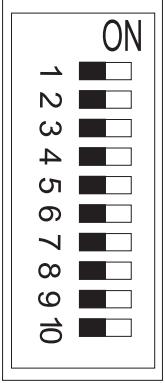
	DIP switches 3 2 1 reserved or baud rate if DIP switch 9 = OFF
	DIP switches 8 7 6 5 4 0 0 0 0 0 CANSync slave number 0 0 0 0 0 1 CANSync slave number 1 0 0 0 1 0 CANSync slave number 2 1 1 1 1 1 CANSync slave number 32
	DIP switch 9 OFF CANSync-Slave for b maXX controller ON CANSync-Slave for b maXX PLC
	DIP switch 10 Reserved, must be set to OFF

Example 1: CANSync-Slave for b maXX PLC

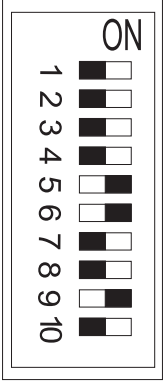
	DIP switches 3 2 1 Reserved
	DIP switches 8 7 6 5 4 0 0 1 1 0 CANSync slave number 6
	DIP switch 9 ON CANSync-Slave for b maXX PLC
	DIP switch 10 Reserved, must be set to OFF

Example 2: CANsync-Slave for b maXX controller

	DIP switches 3 2 1 1 0 1 Baud rate 500 kbps
	DIP switch 8 7 6 5 4 0 0 1 0 0 CANsync slave number 4
	DIP switch 9 OFF CANsync-Slave for b maXX controller
	DIP switch 10 Reserved, must be set to OFF

NOTE

DIP switch 9 = ON:

This plug-in card is a CANsync-Slave option module for **b maXX PLC**
see also the "CANsync Application Manual".

DIP switch 9 = OFF:

This plug-in card is a CANsync-Slave option module for b maXX **controller**
see also [▶Operating the CANsync-Slave option module for b maXX controller ◀](#) from page 37 onward; for information on setting the baud rate, see Assembly, point 7 on [▶Page27](#).



4.2 Danger zones

4.1.2 Slot for CANsync-Slave option module BM4-O-CAN-05

Slot **G** is provided for the CANsync-Slave option module.

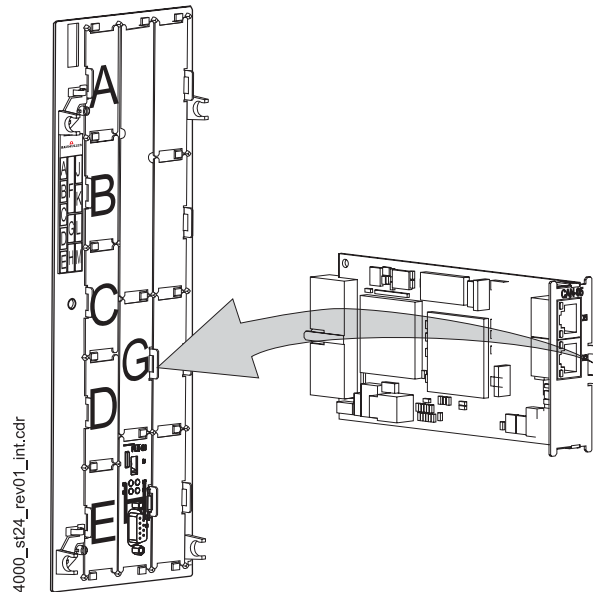

Figure 2: CANsync-Slave module in slot G and b maXX PLC in slot H

NOTE



if you plug a plug-in module into an unsuitable slot, it does not function. We have taken measures to ensure that the plug-in module is not damaged if you do this.

4.2 Danger zones

The b maXX 4400 basic unit that is plugged into this module represents the greatest hazard. Observe all the safety instructions of the b maXX 4400 basic unit. The illustration below gives you an overview of the danger zones in the plug-in module.

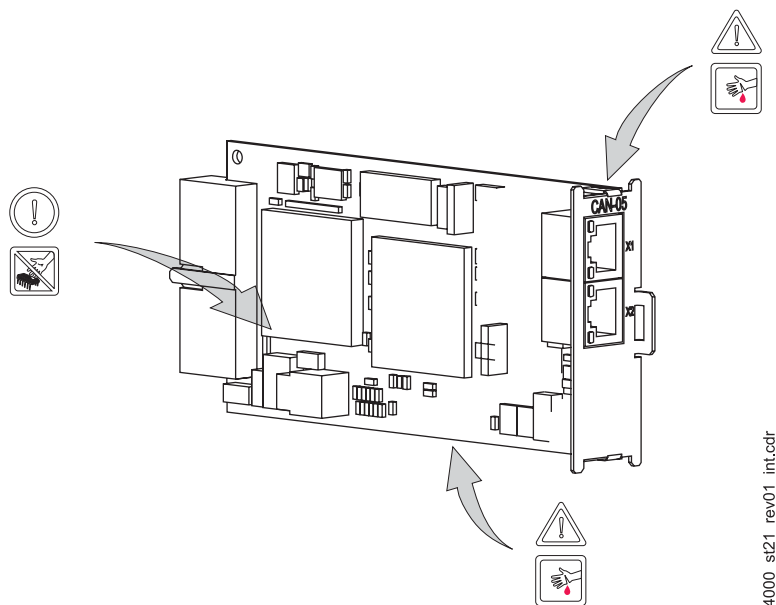

Figure 3: Danger zones

4.3 Marking of the CANsync-Slave option module type code

On the front panel, you will find the type code ("D" in [▶Figure 1](#) on page 17) of the plug-in module.

NOTE

This type code applies only to the CANsync-Slave option modules of series b maXX 4400. Other plug-in modules have their own type codes.

<u>BM4</u> - O - CAN - XX	Device generation in which you can install the plug-in module
BM4 - <u>O</u> - CAN - XX	Option module
BM4 - O - <u>CAN</u> - XX	Plug-in module type (b maXX CAN)
BM4 - O - CAN - <u>XX</u>	Version
	05: CANsync-Slave
	06: CANsync-Master for b maXX PLC

You will find this type code on the front of the front panel and on the bus connector (see A in [▶Figure 1](#) on page 17). The type code contains the plug-in module's basic data. On the basis of the type code, you will be able to find more data in the chapter entitled "Technical Data". For a list of all the technical data, refer to [▶Appendix D Technical Data](#) from page 71 onward.

4.3 Marking of the CANsync-Slave option module type code

ASSEMBLY AND INSTALLATION

In this chapter, we will describe mechanical assembly and electrical installation of a CANsync-Slave option module.

Assembly/installation consists of the following steps:

- 1 Mount the plug-in module.
- 2 Connect the plug-in module to the communication cables.

5.1 General safety regulations

- Observe the information in chapters [►Basic Safety Instructions ◀](#) from page 7 onward.
- Observe all areas on the b maXX 4400 unit that could be dangerous when you are carrying out assembly.

The figure below gives you an overview of the danger zones on the plug-in module.

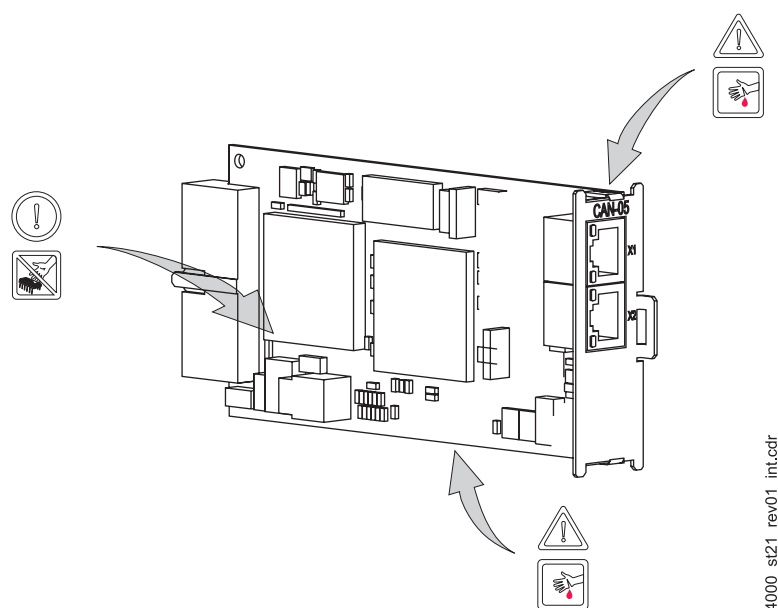

Figure 4: Danger zones

5.2 Requirements of the personnel carrying out work



DANGER

The following **will occur**, if you do not observe this danger information:

- serious personal injury
- death

*Danger from: **electricity**. The unit and the vicinity of the control cabinet may carry dangerous voltages.*

Before starting any work, ensure that the unit and its vicinity are free of voltage.

Observe the relevant safety regulations when handling current-carrying units.

Ensure that only qualified personnel assembles and installs this plug-in module.

Qualified personnel is considered to be people whose training, experience and knowledge of relevant standards and regulations, accident prevention regulations and conditions in the plant has led to their being authorized by the plant safety manager to carry out activities that are needed in each case while recognizing and avoiding any possible hazards that might arise. The qualifications that are necessary for working with the unit include, for example:

- Trained or instructed in accordance with recognized safety standards in the care and use of appropriate safety equipment

5.3 Preparation

- Consult the type code (see "D" in [▶Figure5](#) on page 24) to ensure that you have the correct plug-in module.

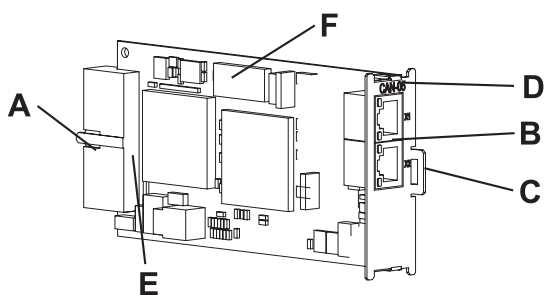

4000_sf22_rev01_int.cdr

- A = Plug connector (back-mounted)
- B = Socket RJ45 (front)
- C = Grip
- D = Type code
- E = Serial number
- F = DIP switch

Figure 5: CANsync-Slave option module for b maXX PLC

- Determine the correct slot (see [▶Figure6](#) on page 25).

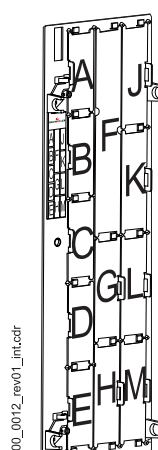

	Function modules						Option modules											
		BM4-F-ENC-XX (encoder 1 for motor management)	BM4-F-ENC-XX (encoder 2)	BM4-F-AIO-XX (analog I/O)	BM4-F-DIO-XX (digital I/O)	BM4-F-IEE-XX (incremental encoder emulation)	BM4-F-CAN-01 (CANsync-Slave)	BM4-O-SER-XX (Sercos-Slave) in preparation	BM4-O-ETH-XX* (Ethernet-Slave)	BM4-O-CAN-05 (CANsync-Slave)	BM4-O-PRO-01 (Profibus-Slave) in preparation	BM4-O-CAN-03 (CANopen-Slave)	BM4-O-PLC-XX (PLC)	BM4-O-CAN-06* (CANsync-Master)	BM4-O-PRO-02* (Profibus-Master) in preparation	BM4-O-CAN-04* (CANopen-Master)	BM4-O-IEI-XX* (incremental counter module)	BM4-O-MFM-XX* (digital and analog I/O module) in preparation
A	X	-	-	o	-	-	-	-	-	-	-	-	-	-	-	-	-	
B	-	X	-	o	-	-	-	-	-	-	-	-	-	-	-	-	-	
C	-	-	-	o	X	X	-	-	-	-	-	-	-	-	-	-	-	
D	-	-	-	X	-	-	-	-	-	-	-	-	-	-	-	-	-	
E	-	-	X	o	-	-	-	-	-	-	-	-	-	-	-	-	-	
F	Controller section permanently installed																	
G	-	-	-	-	-	-	o	X	X	o	o	-	X	X	X	X	X	
H	-	-	-	-	-	-	X	-	o	X	X	X	-	-	-	-	-	
J	-	-	-	-	-	-	o	o	o	o	o	o	o	o	o	o	o	
K	-	-	-	-	-	-	o	o	o	o	o	-	o	o	o	o	o	
L	-	-	-	-	-	-	o	o	o	o	o	-	o	o	o	o	o	
M	-	-	-	-	-	-	o	o	o	o	o	-	o	o	o	o	o	

- X:** Preferred slot
Baumüller Nürnberg Electronic GmbH & Co. recommends fitting plug-in modules in this slot.
- o:** Possible slot
Baumüller recommends fitting the plug-in modules in this slot only if the preferred slot is already assigned
- :** Not possible – the board does not function in this slot.
- *** The condition for these boards is that a PLC module is fitted.

Figure 6: Combinations of slots

5.4 Assembly

- 1 Switch off the b maXX 4400 basic unit and secure it from being unintentionally restarted during assembly.

DANGER



The following **will occur**, if you do not observe this danger information:

- serious personal injury
- death



Danger from: electricity. The unit and the vicinity of the control cabinet may carry dangerous voltages.

Before starting any work, ensure that the unit and its vicinity are free of voltage. Observe the relevant safety regulations when handling current-carrying units.

- 2 Pull the cover forward from the controller section: you can now see the slots.
- 3 Look for the intended slot (**G**) on the controller section.

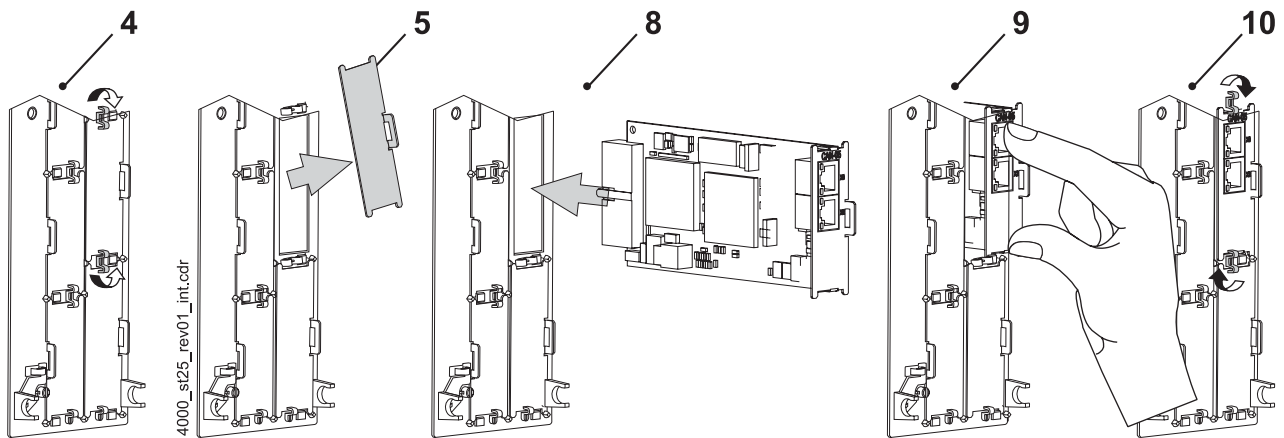

Figure 7: Assembly

- 4 Turn the spagnolet locks above and below this slot by 90°. The spagnolet locks are now horizontal.
- 5 Take out the front panel cover forward. Keep this cover. If you remove plug-in cards, you must close the unit again using the cover.

CAUTION



The following **may occur**, if you do not observe this caution information:

- property damage.



Danger from: electrostatic discharge. The *CANsync-Slave option module* contains ESD components.

Observe the described ESD measures when handling the plug-in module.

Only hold the plug-in module by the gripping piece (see "C" in [►Figure5](#) on page 24).

- 6 Observe the described ESD measures when handling the modules.

7 Remove the CANsync-Slave option module for b maXX option module from the transportation packaging: Avoid contact with the plug-in module's electronic components. Set the DIP switches:

- The following setting makes the option module a CANsync-Slave for the b maXX **PLC**: (slave number 6 is just an example)

	DIP switches 3 2 1 Reserved 0 0 0
	DIP switches 8 7 6 5 4 0 0 1 1 0 CANsync slave number 6
	DIP switch 9 ON CANsync-Slave for b maXX PLC
	DIP switch 10 Reserved, must be set to OFF

- The following setting makes the option module a CANsync-Slave for the b maXX **controller**: (slave number 4 is just an example). In this option module application, you must use DIP switches 1 to 3 to set the baud rate (in the illustration, this is 500 kbps):

	DIP switch 3 2 1 Baud rate 0 0 0 Reserved 0 0 1 Reserved 0 1 0 Reserved 0 1 1 125 kbps 1 0 0 250 kbps 1 0 1 500 kbps 1 1 0 1 Mbps 1 1 1 Reserved
	DIP switches 8 7 6 5 4 0 0 1 0 0 CANsync slave number 4
	DIP switch 9 OFF CANsync-Slave for b maXX controller
	DIP switch 10 Reserved, must be set to OFF

8 Plug the CANsync-Slave option module into the slot's guide rails. The gripping piece must face the same way as the other gripping pieces in this slot rail slot rail (in the case: the right-hand side).

- 9 Keep pressing two fingers on the front panel until you feel the card engage in the end position inside the unit.
- 10 Turn the spagnolet locks above and below this slot by 90° to the vertical position (locked position).
- 11 Remount the cover on the unit.



NOTE

If you only want to replace the CANsync-Slave option module for b maXX within the scope of repairs with a card of the same type, the rest of the procedure is considerably shorter. In this case, you only need to restore the connections to the module, put the front cover back on and switch the unit on again.

This completes assembly of the CANsync-Slave option module. Connecting lines and commissioning is shown in the following sections.

5.5 Installation

At installation, you wire the CANsync-Slave option module for b maXX PLC.

5.5.1 Connection diagram

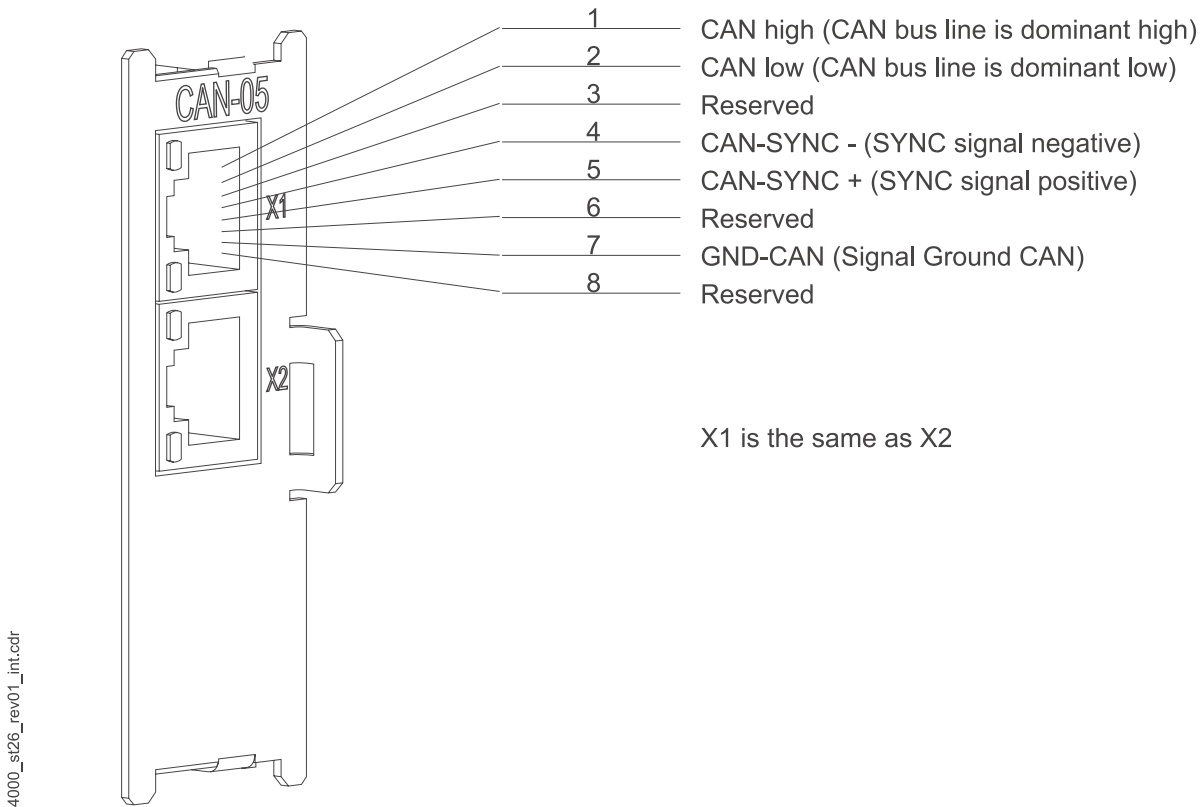

Figure 8: Connection diagram of CANsync-Slave option module for b maXX PLC

5.5.2 Requirements of electrical connection



CAUTION

The following **may occur**, if you do not observe this caution information:

- property damage.

Danger from: **electrical voltage**. *If you are not able to ensure the plug-in module's requirements of the electrical connection, the plug-in module can be damaged or destroyed.*

Ensure that you comply with the connection values that are specified in the technical data and that the connections were made in accordance with the stipulations.

Prevent short-circuits between inputs/outputs. In the case of a short-circuit between inputs/outputs, the plug-in module can be destroyed.

To be able to comply with Standard EN 60 204-1 (Electrical Equipment of Machines), you must use the cables that are suggested in the standard. The connectors must not drop; otherwise, there is a risk of short-circuits or external voltages, etc.

- Ensure EMC-appropriate laying of the connection cables.

5.5.3 Requirements of the connection cable

Baumüller has released the following cables for use:

- For CANsync communication cable BM4-CAN-K-33-xx (other cables and order designations, see [►B.1 List of all accessories◄](#) from page 65 onward)

5.5.4 Sequence of installation

- Ensure that the b maXX unit is deenergized
- Remove the front cover from the unit.
- The CANsync-Slave option module is in slot G, see [►Figure6](#) on page 25.
- Connect the 8-pin RJ45 female connector on the CANsync-Slave option module's front panel to the CANsync communication cable, for the connection assignment, see [►D.2 Pin assignment of RJ45 female connectors X1 and X2◄](#) from page 72 onward.
- Connect the second 8-pin RJ45 female connector on the CANsync-Slave option module's front panel to the CANsync communication cable to the next CANsync-Slave or plug in a terminating resistor connector (see [►B.1 List of all accessories◄](#) from page 65 onward).
- Remount the cover on the unit.
- Lay the connecting lines as stipulated in the control cabinet

This completes installation.

COMMISSIONING

In this chapter, we will describe how you commission the CANsync-Slave option module that you just assembled and installed (see [▶Assembly and installation ◀](#) from page 23 onward). Commissioning ensures that the CANsync-Slave option module functions correctly. For more information on programming refer to the "b maXX PLC Application Manual" and the "CANsync for b maXX Application Manual".

Before starting commissioning, ensure that the following conditions have been met:

- 1 The plug-in module has been assembled correctly.
- 2 The plug-in module has been installed correctly.
- 3 All the safety equipment has been commissioned.
- 4 The b maXX 4400 basic unit is ready for use.

6.1 General safety regulations

- Observe the [▶Basic Safety Instructions ◀](#) from page 7 onward.



DANGER

The following **will occur**, if you do not observe this danger information:

- serious personal injury
- death



Danger from: **mechanical effects**. *At commissioning, the drive can rotate.*

Keep far enough the rotating parts. Note that when drives are starting up machine parts can be set in motion. In all cases, activate the machine's safety devices.

6.2 Requirements of the personnel carrying out work

Commissioning work must only be carried out by trained specialists who have understood the safety regulations and information and can implement them.

6.3 Description/inspection of the safety and monitoring systems

6.3 Description/inspection of the safety and monitoring systems

Before you commission the CANsync-Slave option module, you must eliminate any errors/error messages that may be present on the b maXX 4400 basic unit. These errors may be due to faulty assembly (e.g. defective cables) or faulty installation. You must not continue with commissioning until you have eliminated the errors.

6.4 Description and inspection of the controls and displays

6.4.1 Sample Configuration

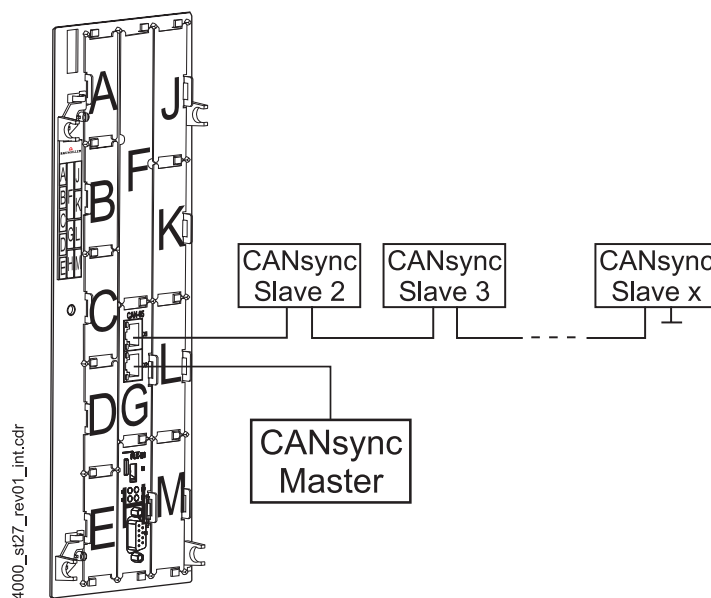

Figure 9: b maXX with CANsync-Slave for b maXX PLC in option slot G and b maXX PLC in option slot H

6.4.2 LEDs

RJ45 female connectors X1 and X2 have two LEDs each (green and red), which will be referred to from now on as H1 to H4. During initialization and operation of the CANsync-Slave option module, the LEDs have different meanings.

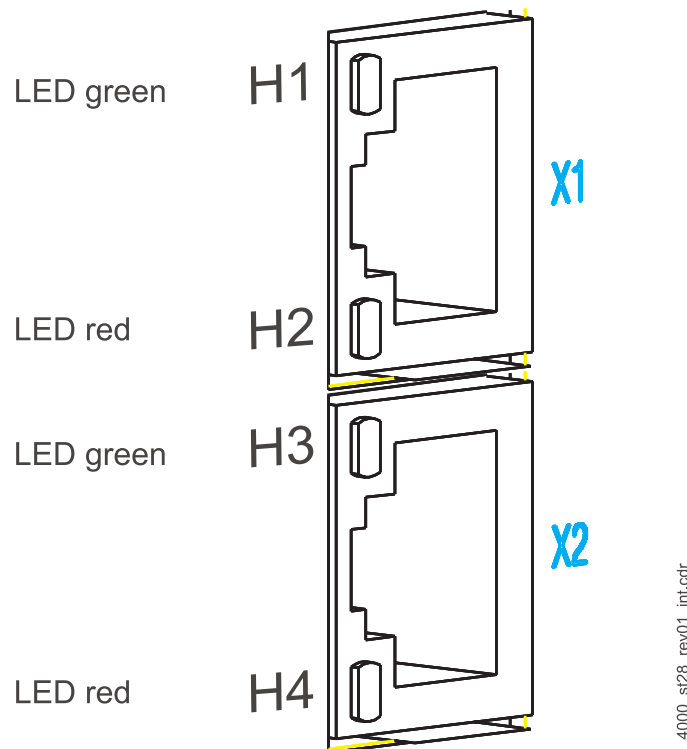

Figure 10: Magnified representation of the LEDs on the front panel

6.4.2.1 Activating and initializing the CANsync-Slave option module for b maXX PLC

After switching on, the LEDs briefly light up one after the other in the following order: H1 (green), H2 (red), H3 (green), H4 (red).

After this, the CANsync-Slave option module is initialized. When doing this, the system displays the following pattern:

Start of initialization H1 on, H2 to H4 off

End of initialization H3 on, H1, H2 and H4 off

Initialization completed H1 to H4 off

This completes basic initialization of the CANsync-Slave option module. If an error occurred during initialization, LEDs H2 and H4 flash in synch.

To find out how to eliminate the cause of the error, refer to [Finding and eliminating disturbances](#) from page 51 onward.

6.4.2.2 Commissioning the CANsync-Slave option module for b maXX PLC

After initializing the CANsync-Slave option module, an application program on the b maXX PLC can configure the option module.

Now, the CANsync-Slave option module shows LED H1 = ON to indicate that it is waiting to be configured by the PLC.

In the case of the b maXX PLC option module, we also refer to configuration of the CANsync-Slave option module as "initializing the CANsync-Slave adapter on the CANsync-Slave option module for b maXX PLC".

6.4 Description and inspection of the controls and displays

For more information, refer to the "b maXX PLC Application Manual" and the "CANsync for b maXX Application Manual".

After an application program on the b maXX PLC has configured the option module, the LEDs have the following meanings:

H1 (green) shows message frames being received and sent to the CANsync-Bus an.

H2 (red) shows that the synchronizing signal on the CANsync bus has failed.

H3 (green) flashes to show the duration of a SYNC interval on the CANsync bus in accordance with the following pattern:

Pattern	SYNC Interval (baud rate)
One flash then a pause	1 ms (1 Mbps)
Two flashes then a pause	2 ms (500 kbps)
Four flashes then a pause	4 ms (250 kbps)
Eight flashes then a pause	8 ms (125 kbps)

H4 (red) is normally off and only flashes in the case of a fault.

To find out how to eliminate the cause of the error, refer to [►Finding and eliminating disturbances ◀](#) from page 51 onward.

6.4.2.3 Activating and initializing the CANsync-Slave option module for b maXX controller

After switching on, the LEDs briefly light up one after the other in the following order: H1 (green), H2 (red), H3 (green), H4 (red).

After this, the CANsync-Slave option module is initialized. When doing this, the system displays the following pattern:

Start of initialization H1 on, H2 to H4 off

End of initialization H3 on, H1, H2 and H4 off

Initialization completed H1 to H4 off

This completes basic initialization of the CANsync-Slave option module. If an error occurred at initialization, LED H2 flashes.

To find out how to eliminate the cause of the error, refer to [►Finding and eliminating disturbances ◀](#) from page 51 onward.

6.4.2.4 Commissioning the CANsync-Slave option module for b maXX controller

After initializing the CANsync-Slave option module, you configure the option module according to the parameters that are set in WinBASS II for the option module.

For more information on this topic, see [►Operating the CANsync-Slave option module for b maXX controller ◀](#) from page 37 onward.

After configuring the option module, the LEDs have the following meanings:

H1 (green) shows message frames being received and sent to the CANsync-Bus an.

H2 (red) shows that the synchronizing signal on the CANsync bus has failed.

H3 (green) flashes to show the duration of a SYNC interval on the CANsync bus in accordance with the following pattern:

Pattern	SYNC Interval (baud rate)
One flash then a pause	1 ms (1 Mbps)
Two flashes then a pause	2 ms (500 kbps)
Four flashes then a pause	4 ms (250 kbps)
Eight flashes then a pause	8 ms (125 kbps)

H4 (red) is normally off and only flashes in the case of a fault.

To find out how to eliminate the cause of the error, refer to [►Finding and eliminating disturbances ◀](#) from page 51 onward.

H2 (red) and H4 (red) flash alternately:

You used DIP switches 1 to 3 to set a baud rate that the option module does not support.

H2 (red) and H4 (red) ON:

The option module is configured and is waiting for the CANsync-Master to start the CANsync bus.

6.5 Commissioning sequence

Commissioning the CANsync-Slave option module for b maXX PLC is divided into the following steps:

- 1 Detecting the CANsync-Slave option module for b maXX PLC
- 2 Testing the function.

Commissioning the CANsync-Slave option module for b maXX controller is divided into the following steps:

- 1 Detecting the CANsync-Slave option module for b maXX controller.
- 2 Testing the function.

6.5.1 Detecting the CANsync-Slave option module for b maXX PLC

- Read and observe the [►General safety regulations ◀](#) from page 31 onward.
- You must have carried out correctly section "Assembly and Installation".
- Switch on the b maXX 4400.



NOTE

You must not remove or plug in the CANsync-Slave option module while the b maXX unit is switched on. Switch the unit off first.

6.5.2 Testing the function of the CANsync-Slave option module for b maXX PLC

After activation, the LEDs flash one after the other (as described in [▶Activating and initializing the CANsync-Slave option module for b maXX PLC](#) ◀ on page 33).

After this, the CANsync-Slave option module shows H1 = ON to indicate that it is waiting to be configured by the b maXX PLC. This completes testing of functioning.

If a complete application is present, LED H1 then shows receiving and sending of message frames on the CANsync bus and H3 uses a flashing sequence to show the SYNC interval and, with this, the baud rate. See [▶Commissioning the CANsync-Slave option module for b maXX PLC](#) ◀ on page 33.

6.5.3 Detecting the CANsync-Slave option module for b maXX controller.

- Read and observe the [▶General safety regulations](#) ◀ from page 31 onward.
- You must have carried out correctly section "Assembly and Installation".
- Switch on the b maXX 4400.

6.5.4 Testing the function of the CANsync-Slave option module for b maXX controller

After activation, the LEDs flash one after the other (as described in [▶Activating and initializing the CANsync-Slave option module for b maXX controller](#) ◀ on page 34).

The CANsync-Slave option module then shows H2 = ON and H4 = ON to indicate that configuration is completed and that it is waiting for the CANsync bus to start communication (the CANsync-Master starts the CANsync bus). This completes testing of functioning.

If a complete application is present, LED H1 then shows receiving and sending of message frames on the CANsync bus and H3 uses a flashing sequence to show the SYNC interval and, with this, the baud rate. See [▶Commissioning the CANsync-Slave option module for b maXX controller](#) ◀ on page 34.

OPERATION

7.1 Operating the CANSync-Slave option module for b maXX PLC

For a guide to operating the CANSync-Slave option module for b maXX **PLC**, refer to the CANSync for b maXX PLC Application Manual and to the b maXX PLC Application Manual as well as to the PROPROG wt II Programming Manual.

7.2 Operating the CANSync-Slave option module for b maXX controller

For a guide to operating the CANSync-Slave option module for b maXX **controller**, refer to the CANSync for b maXX Application Manual.

The aim of CANSync development, i.e. to replace mechanical line shafts by an electronic leading was achieved by making available to all the connected drives (\Rightarrow CANSync slaves) the leading axle value at the same instant (time-synchronous transfer).

The CAN bus represents the physical basis. The bus was enhanced by adding a synchronization signal (SYNC signal). The SYNC signal is transferred on two additional wires in the CAN cable. The SYNC signal is for hardware synchronizing the CANSync master with all the CANSync slaves that are located on the CANSync bus. By contrast with the CAN bus, this makes it possible to send and receive message frames at defined instants. The system achieves a guaranteed, high data throughput rate, which, in addition, has a fixed time reference on the CANSync bus.

The CANSync bus is a master-slave bus with one CANSync master and up to 32 CANSync slaves. To differentiate the CANSync slaves each one is assigned a slave number. You specify the slave number by setting DIP switches.

"Process data"

Process data transfer is on a cyclical basis and involves transferring the control word, the status word, the specified values and the actual values. At a baud rate of 1 Mbps, the CANSync cycle time is 1 ms. For transferring the specified values to the CANSync-Slave option module, this means that the CANSync-Master sends specified value message frame 1 in specified value channel 1 (WRC1) at each CANSync interval exactly 350 μ s after the falling edge of the SYNC signal. The system sends specified value message frame 2 in specified value channel 2 (WRC2) at every CANSync interval exactly 650 μ s

after the falling edge of the SYNC signal. After a request from the CANsync-Master, the CANsync-Slave option module sends its actual value message frame 1 in actual value channel 1 (RDC1) 520 μ s at the latest after the falling edge of the SYNC signal. The CANsync-Slave sends its actual value message frame 2 in actual value channel 2 (RDC2) 820 μ s at the latest after the falling edge of the SYNC signal.

The status word must be sent as an actual value to the CANsync-Master; the CANsync-Master sends the control word on the command channel (CC).

The control word corresponds to the DRIVECOM standard and has parameter number 300. The b maXX controller supplies the status word and it has parameter number 301.

At process data communication between the CANsync-Master and the CANsync-Slave, the system transfers the specified values in the specified value message frames (Master \rightarrow Slave) and the actual values in the actual value message frames (Slave \rightarrow Master).

In each specified value message frame, the CANsync-Master is able to transfer two 32-bit specified values, four 16-bit specified values or one 32-bit specified value and two 16-bit ones.

In each actual value message frame, it is possible to send to the CANsync-Master two 32-bit actual values, four 16-bit actual values or one 32-bit actual value and two 16-bit ones. One 16-bit actual value is the status word.

For process data communication between the b maXX controller and the CANsync-Slave option module, it is possible to state up to four specified values and up to four actual values. The control word belongs to the specified values and the status word belongs to the actual values.

In the case of the specified values, the system selects a maximum of three specified values from specified value message frames 1 and 2 (that the CANsync-Master sent). One of the specified values is the control word from the command channel.

In the case of the actual values, the system selects a maximum of four actual values (including the status word) that are sent to the CANsync-Master in actual value message frames 1 and 2.

Overview of settings that must be made

Settings on the CANsync-Slave option module:

- Baud rate
- Slave number

Settings on WinBASS II page "synchronization":

- Source for sync signal
- SYNC tolerance
- SYNC offset

Settings on WinBASS II page "BACI":

- Parameter number of specified value 1
- Parameter number of specified value 2
- Parameter number of specified value 3
- Parameter number of specified value 4
- Parameter number of actual value 1
- Parameter number of actual value 2
- Parameter number of actual value 3
- Parameter number of actual value 4

Settings on WinBASS II page "option modules G, H – configuration":

- Mapping for specified value 1
- Mapping for specified value 2
- Mapping for specified value 3
- Mapping for specified value 4
- Mapping for actual value 1
- Mapping for actual value 2
- Mapping for actual value 3
- Mapping for actual value 4

Settings on WinBASS II page "drive management":

- Communication via BACI

Settings on WinBASS II page "data record management":

- Save the set data

7.2.1 Settings on the CANsync-Slave option module

To set the data transfer rate (baud rate), you must use the DIP switches (F in [▶Figure1](#) on page 17) to set the baud rate and the slave number and then use WinBASS II to assign the parameters of the b maXX controller with the appropriate values.

For information on setting the DIP switches, refer to chapter [▶DIP switches](#) ◀ from page 17 onward. For more information on this topic, see also the chapter entitled Assembly from [▶Page27](#) onward.

You use DIP switches 1 to 3 to set the CANsync-Slave's baud rate.

You use DIP switches 4 to 8 to set the CANsync-Slave's slave number on a binary basis. This means that you can choose a slave number between 0 and 31.

The setting of the slave number does not depend on the sequence of the CANsync-Slaves in CANsync bus wiring. You may only assign each slave number in a contiguous CANsync bus to one CANsync adapter. This means it is not possible to make duplicate or multiple assignments of slave numbers. You do not, however, need to assign the slave numbers contiguously in ascending order.

7.2 Operating the CANsync-Slave option module for b maXX controller

7.2.2 Settings on WinBASS II page "synchronization"

In parameter "Source for SYNC signal", choose "Use Sync 1 signal from the BACI".

The CANsync-Slave option module sets the Sync interval parameter as follows, in dependence on the baud rate:

Baud rate on the CAN-sync bus	Setting of parameter "Sync interval" (automatically by the option module)
1 Mbps	1000 (µs)
500 kbps	2000 (µs)
250 kbps	4000 (µs)
125 kbps	8000 (µs)

Set -25 (µs) for parameter "Sync offset".

Set 2 (µs) for parameter "Sync tolerance".

With a baud rate of 1 Mbps, WinBASS II page "synchronization" looks something like this:

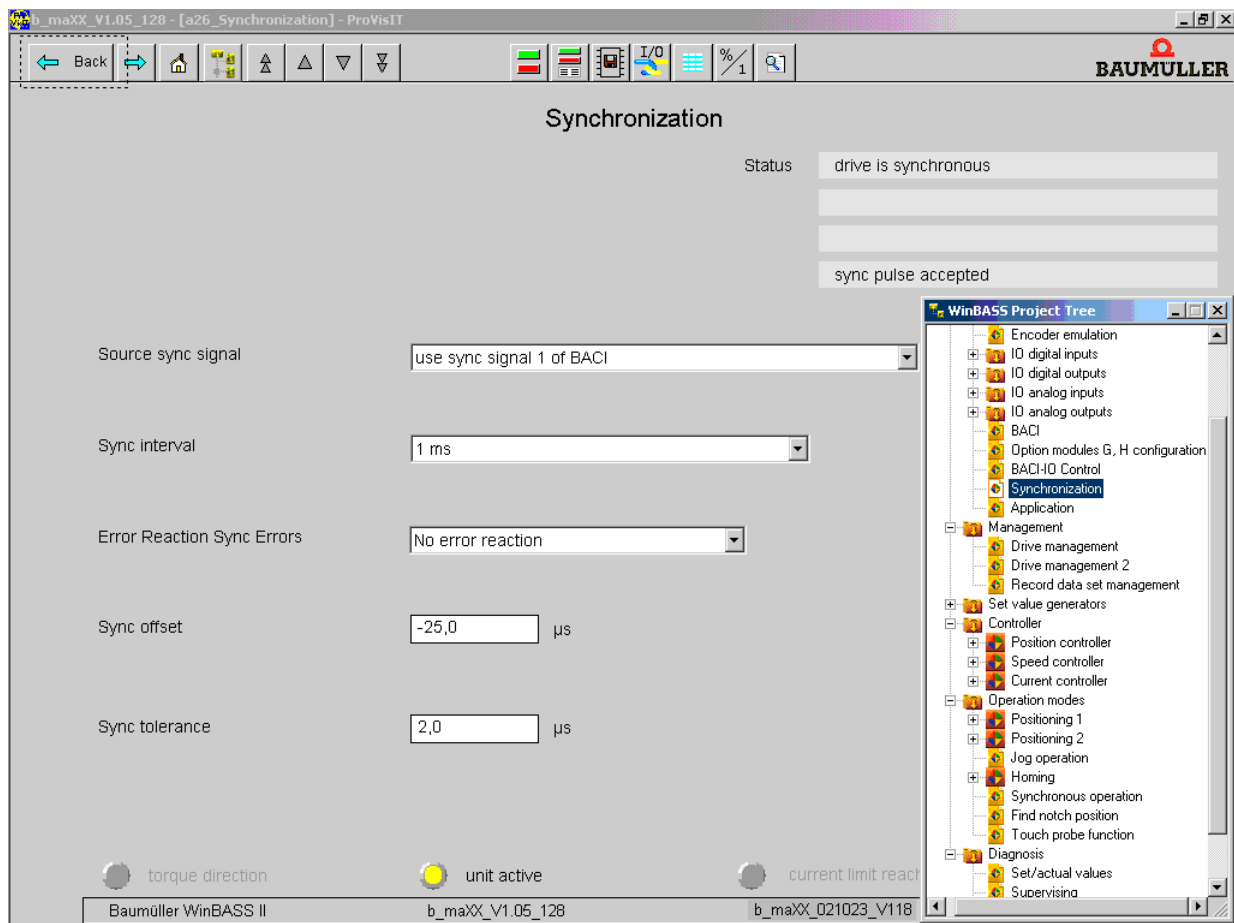

Figure 11: WinBASS II page "synchronization"

7.2.3 Settings on WinBASS II page "BACI":

Enter the parameter numbers of the process data specified values in parameters specified value 1 to specified value 4. The last process data specified value must be the control word (300). There must be no gaps in the setting. Enter the parameter numbers of the process data actual values in parameters actual value 1 to actual value 4. The last process data actual value must be the status word (301). There must be no gaps in the setting.

The CANsync-Slave option module sets parameters specified values of cycle offset and actual values of cycle offset in dependence on the Sync interval parameter.

Example: specified value 1 is the synchronous operation position specified value (BM_ud_SynCtrlPosSetValue, parameter 471),

Specified value 2 is the control word (BM_w_Controlword, Parameter 300)

Actual value 1 is the position actual value (BM_ud_PosActValue, Parameter 362),

Actual value 2 is the actual operating mode (BM_i_OperationModeAct, Parameter 304),

Actual value 3 is the RPM speed actual value (BM_di_SpeedActValue, Parameter 353),

Actual value 4 is the status word (BM_w_Statusword, Parameter 301)

With the example above, WinBASS II page "BACI" looks something like this:

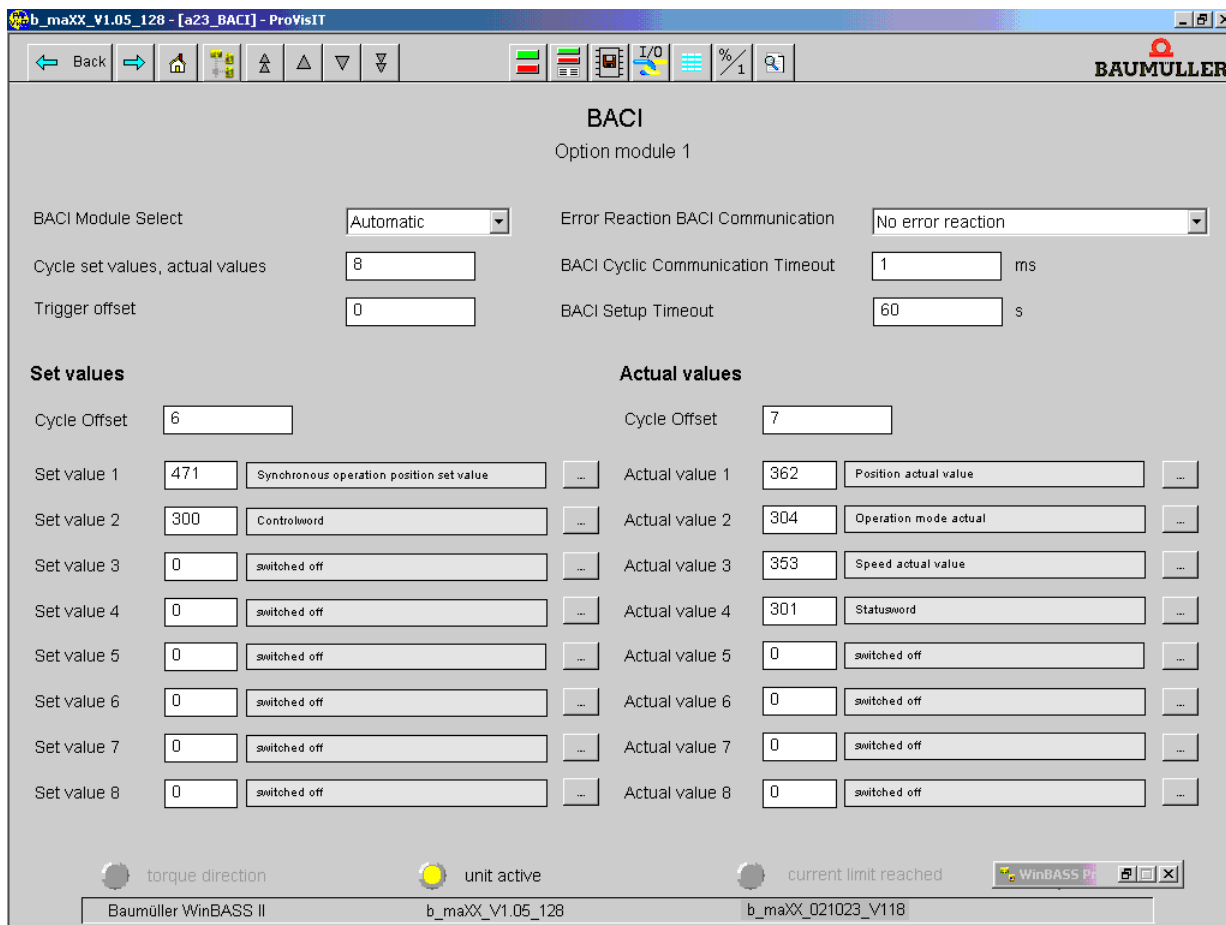

Figure 12: WinBASS II page "BACI"

7.2 Operating the CANsync-Slave option module for b maXX controller

7.2.4 Settings on WinBASS II page "option modules G, H – configuration":

Mapping the specified values

For the following setting, it is assumed that the CANsync-Slave option module is in slot G. In parameters option module G – configuration 1 to option module G – configuration, 4 you state Mapping for specified value 1 to specified value 4. You do not state mapping for the control word.

NOTE

You state the values for mapping in decimal form



Bit 0	Validity 0 : Specified value is invalid 1 : Specified value is valid
Bit 1	Position in specified value or actual value message frame Bit2 Bit1 0 0 : Specified value starts with word 0 (byte 0) in the specified value or actual value message frame
Bit 2	0 1 : Specified value starts with word 1 (byte 2) in the specified value or actual value message frame 1 0 : Specified value starts with word 2 (byte 4) in the specified value or actual value message frame 1 1 : Specified value starts with word 3 (byte 6) in the specified value or actual value message frame* *(Word format only!)
Bit 3	Specified value or actual value message frame no. Bit5 Bit4 Bit3
Bit 4	0 0 0 : Specified value is in specified value or actual value message frame 1 0 0 1 : Specified value is in specified value or actual value message frame 2 0 1 0 : Reserved
Bit 5	... 1 1 1 : Reserved
Bit 6	Format 0: Specified value is of word format 1: Specified value is of doubleword format
Bit 7	Specified value/actual value message frame 0 : Specified value is in a specified value message frame 1 : Specified value is in an actual value message frame (from CANsync-Slave "see Bit 8-12" in this table)

Bit 8	CANsync slave number (if bit 7 = 1)				
Bit 9	Bit12	Bit11	Bit10	Bit9	Bit8
Bit 10	0	0	0	0	0 : CANsync slave number 0
Bit 11	0	0	0	0	1 : CANsync slave number 1
Bit 12	...				
Bit 13	1	1	1	1	0 : CANsync slave number 30
Bit 14	1	1	1	1	1 : CANsync slave number 31
Bit 15	Reserved				

Example: The data for specified value 1 (synchronous operation position specified value, parameter 471) is in words 0 and 1 of specified value message frame 1

	Reserved			Not used, since bit 7 = 1					Specified value is in a specified value message frame Doubleword format	Specified value is in specified value message frame 1			Specified value starts with word 0		: Specified value is valid	
Bit	15	14	13	12	11	10	9	8	7	6	5	4	3	2	1	0
Binary value	0	0	0	0	0	0	0	0	0	1	0	0	0	0	0	1
Hexadecimal value	0			0					4			1				
	16#0041															
Decimal value	65															

In "Option module G – configuration 1", you enter 65 as the mapping for "specified value 1".

You do not enter a mapping for specified value 2, since this specified value is the control word (and the control word is not sent in the specified value message frames).

In "option module G – configuration 2", you enter 0.

Specified values 3 and 4 are not used.

In "option module G – configuration 3" and "option module G, H – configuration 4", you enter 0.

7.2 Operating the CANsync-Slave option module for b maXX controller

Mapping the actual values

In parameters option module G — configuration 5 to option module G – configuration, 8, you state Mapping for actual value 1 to actual value 4. There must be no gaps. You state a mapping for the status word (bit 6 "format" = 0).



NOTE

You state the values for mapping in decimal form

Bit 0	Validity 0 : Actual value is invalid (do not send) 1 : Actual value is valid (send)
Bit 1	Position in the actual value message frame Bit2 Bit1 0 0 : Actual value starts with word 0 (byte 0) in the actual value message frame 0 1 : Actual value starts with word 1 (byte 2) in the actual value message frame 1 1 : Actual value starts with word 3 (byte 6) in the actual value message frame*) *)Word format only!
Bit 2	
Bit 3	Actual value message frame no. Bit4 Bit3 0 0 : Actual value is in actual value message frame 1 0 1 : Actual value is in actual value message frame 2 1 0 : Reserved 1 1 : Reserved
Bit 4	
Bit 5	Reserved
Bit 6	Format 0 : Actual value is of word format 1 : Actual value is of doubleword format
Bit 7 to Bit 15	Reserved

Example: The data for actual value 1 (position actual value, parameter 362) is in words 2 and 3 of actual value message frame 1

	Reserved			Reserved					Reserved	Doubleword format	Actual value is in actual value message frame 1			Actual value starts with word 2		Actual value is valid
Bit	15	14	13	12	11	10	9	8	7	6	5	4	3	2	1	0
Binary value	0	0	0	0	0	0	0	0	0	1	0	0	0	1	0	1
Hexadecimal value	0			0					4				5			
	16#0045															
Decimal value	69															

In "Option module G – configuration 5", you enter 69 as the mapping for "actual value 1".

The data for actual value 2 (actual operating mode, parameter 304) is in word 1 of actual value message frame 1.

	Reserved			Reserved					Reserved	Word format.	Actual value is in actual value message frame 1			Actual value starts with word 1		Actual value is valid
Bit	15	14	13	12	11	10	9	8	7	6	5	4	3	2	1	0
Binary value	0	0	0	0	0	0	0	0	0	0	0	0	0	0	1	1
Hexadecimal value	0			0					0				3			
	16#0003															
Decimal value	3															

In "Option module G – configuration 6", you enter 3 as the mapping for "actual value 2".

The data for actual value 3 (RPM speed actual value, parameter 353) is in word 1 of actual value message frame 2.

7.2 Operating the CANsync-Slave option module for b maXX controller

	Reserved			Reserved					Reserved	Word format.	Actual value is in actual value message frame 2			Actual value starts with word 1		Actual value is valid
Bit	15	14	13	12	11	10	9	8	7	6	5	4	3	2	1	0
Binary value	0	0	0	0	0	0	0	0	0	0	0	0	1	0	1	1
Hexadecimal value	0			0					0			B				
	16#000B															
Decimal value	11															

In "Option module G – configuration 7", you enter 11 as the mapping for "actual value 3".

The data for actual value 4 (status word, parameter 301) is in word 3 of actual value message frame 2.

	Reserved			Reserved					Reserved	Word format.	Actual value is in actual value message frame 2			Actual value starts with word 3		Actual value is valid
Bit	15	14	13	12	11	10	9	8	7	6	5	4	3	2	1	0
Binary value	0	0	0	0	0	0	0	0	0	0	0	0	1	1	1	1
Hexadecimal value	0			0					0			f				
	16#000F															
Decimal value	15															

In "Option module G – configuration 8", you enter 15 as the mapping for "actual value 4".

With the example above, WinBASS II page "option module G, H – configuration" looks something like this:

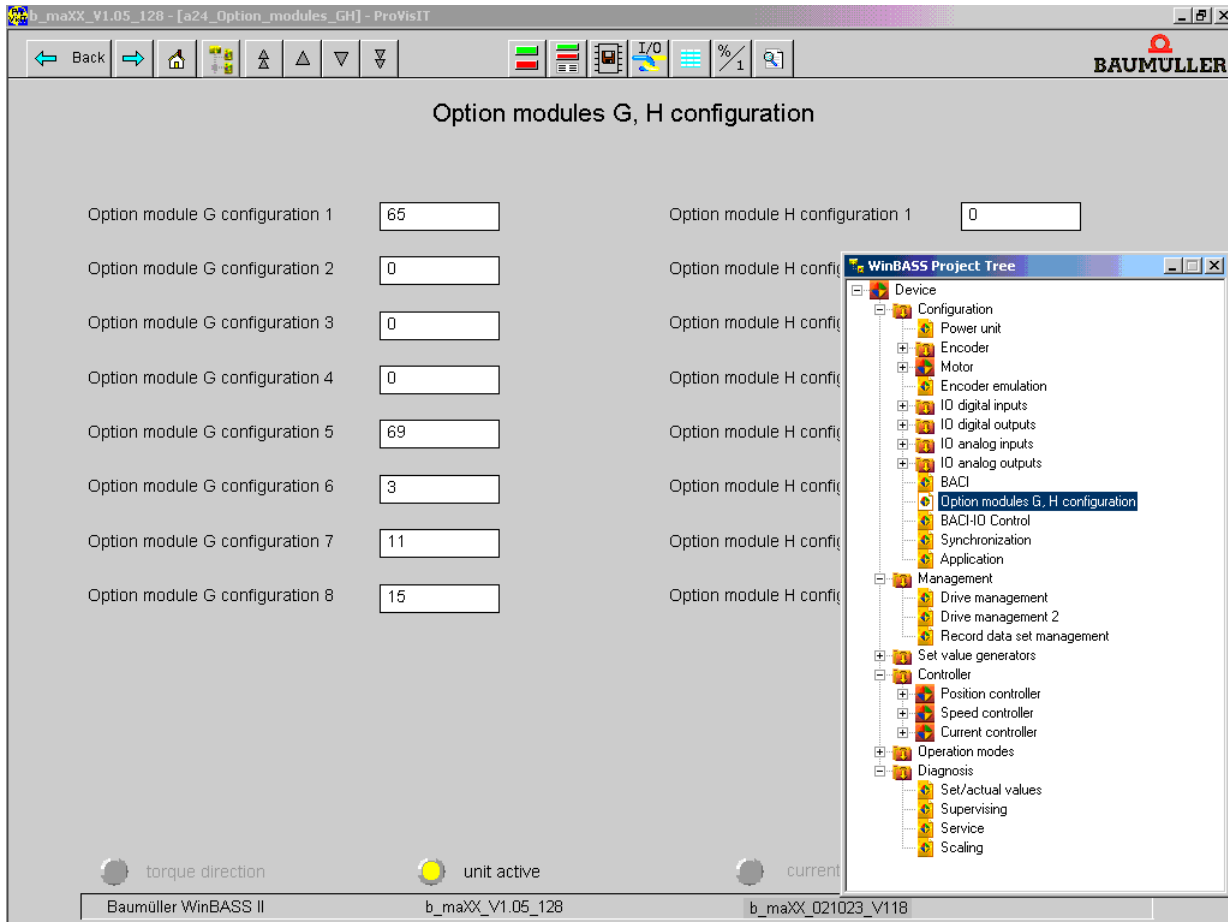

Figure 13: WinBASS II page "option module G, H – configuration"

7.2.5 Settings on WinBASS II page "drive management":

In the Drive Manager, you choose "Control by BACI".

In addition, you choose "BACI, write accesses requirements data released" and "BACI, write accesses process data released".

NOTE



You must deactivate items "CANsync, write accesses requirements data released" and "CANsync, write accesses process data released" with the CANsync-Slave option module!

7.2 Operating the CANsync-Slave option module for b maXX controller

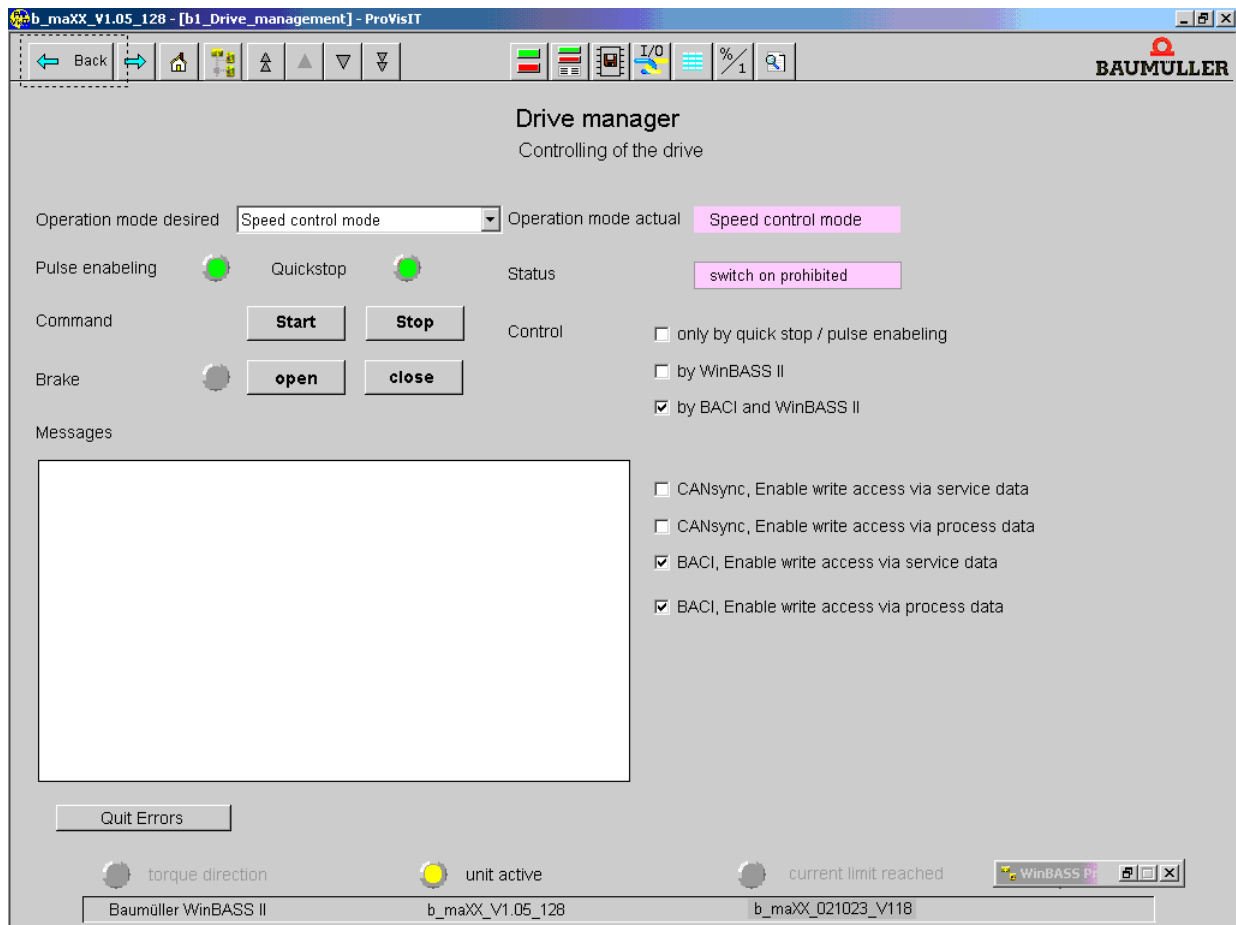

Figure 14: WinBASS II page "drive manager"

7.2.6 Settings on WinBASS II page "data record management":

After you have made all the settings, you must save the in b maXX.

To do this open the "Data record command" window in field "RAM" on "Ds1". Choose "Save" and then click on "OK".

The system uses the settings the next time you switch on the b maXX 4400.

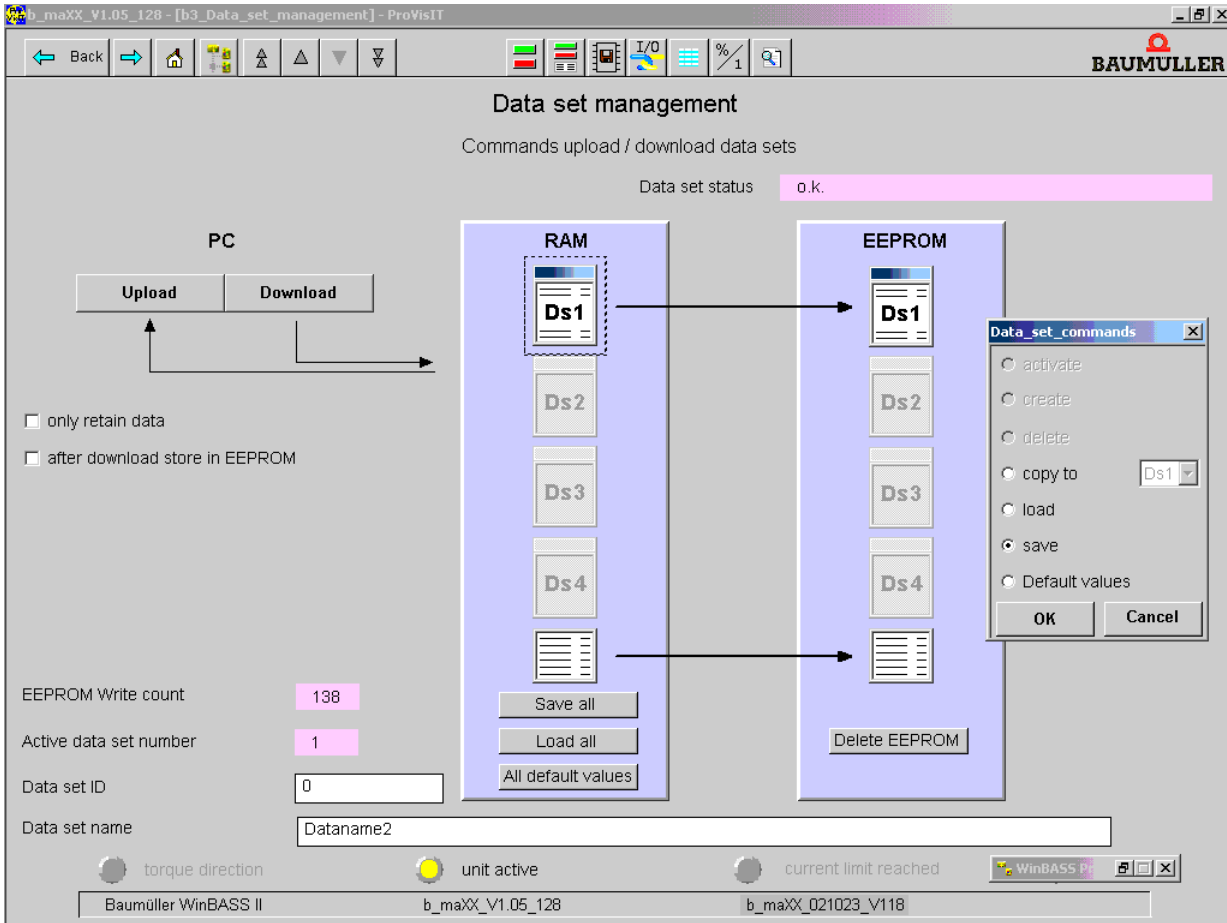

Figure 15: WinBASS II page "data record management"

This completes configuration of the CANsync-Slave option module. Specified value message frames are received from a CANsync-Master and it is possible to send actual value message frames.

8

FINDING AND ELIMINATING DISTURBANCES

In this chapter, we will describe the fault indications of the CANsync-Slave option module. We will explain the meanings of each of these indications and how you can respond to them.

8.1 Safety regulations

- Observe the ► [Basic Safety Instructions](#) ◀ from page 7 onward.

8.2 Requirements of the personnel carrying out work

The personnel who work with the b maXX unit must have been instructed in operating the unit and be familiar with correctly operating it. Responding to error displays and status conditions in particular requires special knowledge that operators must demonstrate. Below, we will inform you about the various disturbances and the error messages that result from them. These disturbances can have mechanical or electrical causes.

8.3 Error messages responses to errors

8.3.1 CANsync-Slave option module for b maXX PLC

The CANsync-Slave option module for b maXX PLC uses LEDs H2 (red) and H4 (red) to indicate faults.

H2 (red) is normally off.

H4 (red) is normally off and only flashes in the case of a fault.

H2 flashes (but not steadily) or is on:

The SYNC signal is not OK. The application program on the b maXX PLC may possibly have set the wrong baud rate.

H2 and H4 flash in synch:

In this connection, the flashing frequency of H2 and H4 have the following meanings:

Pattern	Meaning	Remedy
One flash then a pause	The hardware is defective or there is no CANsync hardware on the option module	Send the module back to the manufacturer
Two flashes then a pause	No CANsync software on the CANsync-Slave option module	Send the module back to the manufacturer
Three flashes then a pause	You need a newer version of the CANsync software on the CANsync-Slave option module	Send the module back to the manufacturer
Four flashes then a pause	Hardware fault on the b maXX basic unit	Send the unit back to the manufacturer

8.3.2 CANsync-Slave option module for b maXX controller

The CANsync-Slave option module for b maXX controller uses LEDs H2 (red) and H4 (red) to indicate faults.

H2 (red) is normally off.

H4 (red) is normally off.

H2 ON: No SYNC signal is connected.

H2 flashes (but not steadily) or is on:

The SYNC signal is not OK. You may have set the wrong baud rate on the DIP switches.

H4 flashes (but not steadily) or is on:

There is a communications fault between the CANsync-Slave option module and the b maXX controller

H2 and H4 ON:

No SYNC signal is connected (H2); therefore, there is a communications fault between the CANsync-Slave option module and the b maXX controller (H4).

H2 and H4 flash in synch:

In this connection, the flashing frequency of H2 and H4 have the following meanings:

Pattern	Meaning	Remedy
One flash then a pause	The hardware is defective or there is no CANsync hardware on the option module	Send the module back to the manufacturer
Two flashes then a pause	No CANsync software on the CANsync-Slave option module	Send the module back to the manufacturer
Three flashes then a pause	You need a newer version of the CANsync software on the CANsync-Slave option module	Send the module back to the manufacturer
Four flashes then a pause	Hardware fault on the b maXX basic unit	Send the unit back to the manufacturer

H2 and H4 flash alternately:

If H2 and H4 are flashing alternately, this means that

- one PLC is fitted, which means that the module cannot be used as a CANsync option module for b maXX controller; rather, you must set it as an option module for b maXX PLC (DIP switch 9 = ON); or
- you set a baud rate that the CANsync-Slave option module does not support!

DIP switches **3 2 1** have the invalid setting:

0 0 0
 0 0 1
 0 1 0 or
 1 1 1

	DIP switches 3 2 1 0 0 0 Baud rate 0 0 1 Reserved 0 1 0 Reserved 0 1 1 Reserved 1 0 0 125 kbps 1 0 1 250 kbps 1 1 0 500 kbps 1 1 1 1 Mbps Reserved
	DIP switches 8 7 6 5 4 0 0 1 0 0 CANsync slave number 4
	DIP switches 9 OFF CANsync-Slave for b maXX controller
	DIP switches 10 Reserved, must be set to OFF

8.3 Error messages responses to errors

H2 and H4 ON:

Initialization and configuration of the CANsync-Slave option module are completed; however, the CANsync-Master has not yet started the CANsync bus.

9

MAINTENANCE

If you comply with the specified environmental operating conditions, see [▶Appendix D Technical Data](#) from page 71 onward, the CANsync-Slave option module is maintenance-free. If you find a defect in your CANsync-Slave option module or think that it is defective, contact Baumüller Nürnberg Electronic GmbH & Co. KG.



10

OVERHAUL

You cannot overhaul a defective CANsync-Slave option module, contact Baumüller Nürnberg Electronic GmbH & Co. KG to obtain a replacement.



DISMANTLING, STORAGE

In this chapter, we will describe how you decommission the CANsync-Slave option module and store it.

11.1 Safety regulations

- Observe the [►Basic Safety Instructions ◀](#) from page 7 onward.



WARNING

The following **may occur**, if you do not observe this warning information:

- serious personal injury
- death

*Danger from: **electricity**. The unit carries dangerous voltage and current and residual charges in the intermediate circuit.*

Ensure that all the electrical connections have been deenergized and are secured against re-starting.

Wait until the intermediate circuit has discharged before starting any dismantling work. The capacitors that are used in the unit have discharged automatically **10 min.** after the supply voltage is switched off such that you can dismount the connections without any risk.

Before starting work on the electrical connections, use appropriate measuring equipment to ensure that the connections are dead.

Do not dismount the connections until you are certain that they are dead.

11.2 Requirements of the personnel carrying out work

The personnel that carries out dismantling must have the necessary knowledge and have been trained appropriately to carry out this work. Choose these persons such that they understand and can apply the safety instructions printed on the unit and parts of it and on the connections.

11.3 Dismantling

- Make available the following material before starting dismantling:
 - Suitable packaging for the CANsync-Slave option module; if possible, the original packaging.
 - Cover plate to cover the slot.

Carry out dismantling in the following sequence:

- 1 Deenergize the b maXX 4400 basic unit and secure it from unintentional switch-on.
- 2 Wait ten minutes (the capacitors discharge).
- 3 Open the switching cabinet.
- 4 Remove the b maXX 4400 basic unit's cover.
- 5 Remove the male connectors from the sockets.
- 6 Turn the spagnolet locks above and below the CANsync-Slave option module's front panel slot by 90° (in the horizontal position, they are unlocked).

CAUTION

The following **may occur**, if you do not observe this caution information:

- property damage.

*Danger from: **electrostatic discharge**. The electronic components on the PCB can be damaged or destroyed if you touch them with your hands.*

Only touch the CANsync-Slave option module by the handle on the front panel.



- 7 Pull the CANsync-Slave option module by the handle forward out of the controller section.
- 8 Place the module in the prepared packaging – when doing this, only touch the plug-in module by the handle.
- 9 Now place a cover (or a new CANsync-Slave option module) in the vacant slot (the holder must point toward the left-hand side of the unit).
- 10 Turn the spagnolet locks by 90° (in the vertical position the locks are fastened).
- 11 Remount the cover on the unit.
- 12 Close the switching cabinet.
- 13 Document in writing dismantling (or replacing) the CANsync-Slave option module.

You can now switch the unit back on. If you want to dispose of the module, refer to chapter [▶Entsorgung ◀](#) from page 45 onward for more information.

11.4 Storage conditions

Store the CANsync-Slave option module in suitable packaging according to the storage conditions in [▶Technische Daten ◀](#) from page 55 onward.

11.5 Recommissioning

If you want to recommission the CANsync-Slave option module, observe the information in "Storage Conditions". Then, carry out commissioning again.

DISPOSAL

In this chapter we will describe how you can correctly and safely dispose of the Option Module CANsync-Slave for b maXX. For the most part, you must dispose of electronic scrap.

12.1 Safety regulations

- Observe the ► [Basic Safety Instructions](#) ◀ from page 7 onward.

CAUTION



The following **may occur**, if you do not observe this caution information:

- minor to medium personal injury.



Danger from: *sharp edges*. The components of the CANsync-Slave option module sheet steel parts, etc. can have sharp edges! If you do not hold a CANsync-Slave option module by the handle, you can cut your fingers or the palm of your hand.

You must only ever hold the CANsync-Slave option module by the handle on the front panel.

CAUTION



The following **may occur**, if you do not observe this danger information:

- environmental pollution.



Danger from: *incorrect disposal*.

You must only carry out disposal in accordance with the safety regulations. If necessary, you must also comply with any local regulations. If you cannot safely dispose of the unit yourself, commission a suitable disposal company to carry it out on your behalf.

In case of fire, dangerous compounds may result or hazardous materials may be released.

Do not subject electronic components to high temperatures.

Some high-performance semi-conductors, for example, use beryllium oxide as the internal insulation. The beryllium dust that results on opening is a health risk.

Do not open the electronic components.

12.2 Requirements of the personnel carrying out work

The personnel that carries out disposal/dismantling must have the necessary knowledge and have been trained appropriately to carry out this work. Choose these persons such that they understand and can apply the safety instructions printed on the b maXX 4400 basic unit and parts of it.

12.3 Disposal guide

Conditions	<ul style="list-style-type: none">• The CANsync-Slave option module has already been correctly dismantled.• All the necessary technical aids for dismantling are ready for use and are in perfect technical condition.
Sheet steel	The front panel is made of galvanized sheet steel. Dispose of the sheet steel in your local reusable ferrous metal system.
Electronic scrap	You must dispose of the electronic scrap (PCB) that cannot be further dismantled as special waste. When doing this, observe the applicable regulations.

12.4 Disposal locations/official bodies

Ensure that you carry out disposal in accordance with your company's guidelines and with the regulations of the responsible disposal locations and official bodies. If in doubt, contact the Trade Supervisory Authority that is responsible for your company or the Environmental Protection Authorities.



APPENDIX A - ABBREVIATIONS

BACI	Baumüller Component Interface
BUB	Ballast unit
BUC	Baumüller feed/return feed unit
BUG	Baumüller converter basic feed unit
BUM	Baumüller individual power unit
BUS	Baumüller power module
CAN	Controller Area Network
CANsync	Synchronized CAN
CE	Communauté Européenne (European Community)
CPU	Central Processing Unit
DC	d.c. current
DP-RAM	Dual-port RAM
DIN	Deutsches Institut für Normung e.V. (German Standards Institute)
EMC	Electromagnetic compatibility
EN	European standard
EPROM	
ESD	Discharge of static electricity
I/O	Input/Output
ISO	International Organization for Standardization
LED	Light Emitting Diode
16#	Prefix for hexadecimal numbers
RAM	Random Access Memory
USS	USS protocol function module
USS®	Trademark of Siemens, universal serial interface
VDE	Verband deutscher Elektrotechniker (German Association of Electrical Engineers)



APPENDIX B - ACCESSORIES

This appendix lists all the accessories that are available for Baumüller Nürnberg Electronic GmbH & Co.'s CANsync-Slave option module.

If you have any queries about accessories or suggestions for improvements, Baumüller's Product Management will be pleased to hear from you.

B.1 List of all accessories

Available CANsync communication cables:

Line type: BM4-CAN-K-33-xx (RJ male connector, RJ male connector)

Type	Length [m]	Article Number
BM4-CAN-K-33-0,5	0,5	353315
BM4-CAN-K-33-01	1	346577
BM4-CAN-K-33-02	2	353317
BM4-CAN-K-33-03	3	353321
BM4-CAN-K-33-04	4	353327
BM4-CAN-K-33-05	5	351766
BM4-CAN-K-33-10	10	353329

Line type: BM4-CAN-K-31-xx (RJ male connector, Sub-D male connector)

Type	Length [m]	Article Number
BM4-CAN-K-31-0,5	0,5	353334
BM4-CAN-K-31-01	1	346568
BM4-CAN-K-31-02	2	353335
BM4-CAN-K-31-03	3	346571

B.1 List of all accessories

Type	Length [m]	Article Number
BM4-CAN-K-31-04	4	353337
BM4-CAN-K-31-05	5	351764
BM4-CAN-K-31-10	10	353339

Line type: BM4-CAN-K-32-xx (RJ male connector, female Sub-D connector)

Type	Length [m]	Article Number
BM4-CAN-K-32-0,5	0,5	353330
BM4-CAN-K-32-01	1	346572
BM4-CAN-K-32-02	2	353331
BM4-CAN-K-32-03	3	346573
BM4-CAN-K-32-04	4	353332
BM4-CAN-K-32-05	5	351765
BM4-CAN-K-32-10	10	353333

Terminating resistor connector CAN, RJ45 with CIA standard pin assignment

Type		Article Number
BM4-CAN-T01	RJ45	346408
K-CAN-T1-O	9-pin SUB-D male connector	313910
K-CAN-T2-O	9-pin SUB-D female connector	313911



APPENDIX C - DECLARATION OF CONFORMITY/MANUFACTURER DECLARATION

In this section we provide general information about EC directives, the CE symbol and the Declaration of Conformity/by Manufacturer.

C.1 What is an EC directive?

EC directives specify requirements. The directives are written by the relevant bodies within the EU (which used to be called the EC, and the EEC before that, hence the now illogical term EC directive), and are implemented by all the member countries of the EU in national law. In this way the EC directives guarantee free trade within the EU.

An EC directive only contains essential minimum requirements. You will find detailed requirements in standards, to which references are made in the directive.

C.2 What the CE symbol indicates

a) The CE marking symbolizes conformity to all the obligations incumbent on manufacturers for the product by virtue of the Community directives providing for its affixing.

...

b) The CE marking affixed to industrial products symbolizes the fact that the natural or legal person having affixed or been responsible for the affixing of the said marking has verified that the product conforms to all the Community total harmonization provisions which apply to it and has been the subject of the appropriate conformity evaluation procedures.

...

Council Decision 93/465/EEC, Annex I B. a) + c)

We affix the CE mark to the equipment and to the documentation as soon as we have established that we have satisfied the requirements of the relevant directives.

All converters and control systems supplied by the Baumüller Nürnberg Electronic GmbH & Co. KG satisfy the requirements of 73/23/EEC (Low Voltage Directive).

Provide this Baumüller equipment is subjected to normal use in your machinery you can assume that the equipment satisfies the requirements of 73/23/EEC.

Compliance with 89/336/EEC (EMC Directive) depends on how the equipment is installed. Since you are performing installation yourself, it is you who are responsible for complying with 89/336/EEC.

We will provide you with support in the form of EMC information. You will find this information in the operating instructions of the b maXX 4400 basic unit. When you have complied with all the requirements we impose in this documentation, you can assume that the drive satisfies the requirements of the EMC Directive.

To enable you to market your machine within the EU, you must be in possession of the following:

- Conformity mark (CE mark)
- Declaration(s) of Conformity regarding the directive(s) relevant to the machine

C.3 Definition of the term Declaration of Conformity

A Declaration of Conformity as defined by this documentation is a declaration that the electrical equipment brought into circulation conforms to all the relevant fundamental safety and health requirements.

By issuing the Declaration of Conformity in this section the Baumüller Nürnberg Electronic GmbH & Co. KG declares that the equipment conforms to the relevant fundamental safety and health requirements resulting from the directives and standards which are listed in the Declaration of Conformity.

C.4 Definition of the term Declaration by Manufacturer

A Declaration by Manufacturer as defined by this documentation is a declaration that the machine/safety component brought into circulation conforms to all the relevant fundamental safety and health requirements.

By issuing the Declaration by Manufacturer in this section the Baumüller Nürnberg Electronic GmbH & Co. KG declares that the equipment conforms to the relevant fundamental safety and health requirements resulting from the directives and standards which are listed in the Declaration by Manufacturer.

The Baumüller equipment is integrated into a machine. For health and safety, of the users for example, it is important for the entire machine to conform to all the relevant fundamental safety and health requirements. For this reason the Baumüller Nürnberg Electronic GmbH & Co. KG draws attention in the Declaration by Manufacturer to the fact that it is prohibited to put the machine as a whole into operation before it has been declared that the machine conforms to the provisions of the Machinery Directive.

C.5 Declaration of Conformity

EG-Konformitätserklärung 2002

Declaration of Conformity 2002

gemäß EG-Richtlinie 73/23/EG (Niederspannung) vom 19.02.1973

geändert durch: 93/68/EWG vom 22.07.1993

in accordance with EC directive 73/23/EG (low voltage) dated 19.02.1973

changed by: 93/68/EWG dated 22.07.1993

Option Module CANsync-Slave for b maXX BM4-O-CAN-05

Das obige Gerät wurde entwickelt und konstruiert sowie anschließend gefertigt in Übereinstimmung mit o. g. EG-Richtlinie und u. g. Normen in alleiniger Verantwortung von:

the unit specified above was developed and constructed as well as manufactured in accordance with the above mentioned directive and the standards mentioned below under liability of:

Baumüller Nürnberg Electronic GmbH & Co. KG, Ostendstr. 80 - 90, D-90482 Nürnberg

Berücksichtigte Normen - standards complied with:

Norm / standard

EN 50178	Ausrüstung von Starkstromanlagen mit elektrischen Betriebsmitteln Electronic equipment for use in power installations
EN 60204-1	Sicherheit von Maschinen - Elektrische Ausrüstung von Maschinen Safety of machinery - Electrical equipment of machines
EN 60529	Schutzarten durch Gehäuse (IP Code) Degrees of protection provided by enclosures (IP Code)
HD 625.1 51	Isolationskoordination für elektrische Betriebsmittel in Niederspannungsanlagen Insulation coordination for equipment within low-voltage systems

Nürnberg, November 2002

Dr. Peter Kreisfeld
Geschäftsführer
Head Division

i.A. Dr. Peter Heidrich
Entwicklungsleiter

Head of development Seite 1 von 1 / page 1 of 1

C.6 Manufacturer Declaration

EG-Herstellererklärung 2002

Declaration by Manufacturer 2002

gemäß EG-Richtlinie 98/37/EG (Maschinen) vom 22.06.1998

geändert durch: 98/79/EG vom 27.10.1998

in accordance with EC directive 98/37/EG (machinery) dated 22.06.1998

changed by: 98/79/EC dated 27.10.1998

Option Module CANsync-Slave for b maXX BM4-O-CAN-05

Das obige Gerät wurde entwickelt und konstruiert sowie anschließend gefertigt in Übereinstimmung mit o. g. EG-Richtlinie und u. g. Normen in alleiniger Verantwortung von:

The unit specified above was developed and constructed as well as manufactured in accordance with the above mentioned directive and the standards mentioned below under liability of:

Baumüller Nürnberg Electronic GmbH & Co. KG, Ostendstr. 80 - 90, D- 90482 Nürnberg

Berücksichtigte Normen - standards complied with:

Norm / standard

EN 60204-1	Sicherheit von Maschinen - Elektrische Ausrüstung von Maschinen Safety of machinery - Electrical equipment of machines
------------	---

Die Inbetriebnahme der Maschine, in die dieses Gerät eingebaut wird, ist untersagt bis die Konformität der Maschine mit der obengenannten Richtlinie erklärt ist.

The machinery into which this unit is to be incorporated must not be put into service until the machinery has been declared in conformity with the provisions of the directive mentioned above.

Nürnberg, November 2002

Dr. Peter Kreisfeld
Geschäftsführer
Head Division

i.A. Dr. Peter Heidrich
Entwicklungsleiter
Head of development

Seite 1 von 1 / page 1 of 1



APPENDIX D TECHNICAL DATA

This appendix lists the technical data for Baumüller Nürnberg Electronic GmbH & Co. KG's CANsync-Slave option module.

D.1 Connection values

Baud Rate	1 Mbps, 500 kbps, 250 kbps, 125 kbps
Physical layer	ISO 11898
Potential separation	Optocoupler, DC/DC converter
Plug-in connector	2 x RJ45 female connectors
Operating voltage	+5 V, from controller supply
Current consumption	350 mA
Ambient conditions	Same as b maXX 4400 basic unit
Storage conditions	Same as b maXX 4400 basic unit

D.2 Pin assignment of RJ45 female connectors X1 and X2

D.2 Pin assignment of RJ45 female connectors X1 and X2

Pin No.	Assignment
1	CAN high (CAN bus line is dominant high)
2	CAN low (CAN bus line is dominant low)
3	GND-CAN (Signal Ground CAN)
4	CAN-SYNC - (SYNC signal negative)
5	CAN-SYNC + (SYNC signal positive)
6	Reserved
7	GND-CAN (Signal Ground CAN)
8	Reserved



Index

Numerics

73/23/EWG 67

B

b maXX PLC 5

b maXX controller 5

BACI

Page in WinBASS II 41

Basic unit 5, 60

Baud rate, invalid 53

Baumüller 7, 15

BM4-O-CAN-05 5

BM4-O-PLC-01 5

Board

defective 57

C

CANsync

Communication cable 65

CANsync-Slave module 5

Capacitors 59

CE certification 67

Climatic category 16

Combinations of slots 25

Communication cable 65

Connection cable 30

released 30

Connection diagram 29

Cover 60

D

Data record management

Page in WinBASS II 48

Declaration of Conformity 67, 69

Device generation 21

DIP switches 17

Discharge 60

Dismantling 59, 60

Dismantling, sequence 60

Disposal 61

Disposal guide 62

Disturbance displays on basic unit 51

Disturbance elimination 51

Drive management

Page in WinBASS II 47

E

Electrostatic discharge 15, 26

Electrical connection 29

Error Messages 52

EU guidelines 67

F

Finding disturbances 51

First Steps 5

Front panel 21

G

Gripping piece 26

H

Handle 60

I

Intermediate circuit 59

Introduction 5

L

Leading axle, electronic 37

Low Voltage Directive 67

M

Maintenance 55

Manufacturer Declaration 67, 70

Mapping

Actual Values 44

Specified values 42

O

Option module 5

Option modules G, H – configuration

Page in WinBASS II 42

Option slot 32

Overhaul 57

P

Packaging 15

Personnel 13, 51, 59, 62

qualified 13

Pin assignment 72

Plug-in module 5

Plug-in module type 21

Process data

37

Q

Qualified Personnel 13, 24

R

Recommissioning 60

Responses to errors 52

Responsibility and liability 13

RJ male connector 65

S

Safety Information 7

Safety regulations 51, 61

Safety regulations, dismantling 59



Index

Sample Configuration	32
Settings on WinBASS II	40
Settings, summary	39
Shock	16
Slot	24
Spagnolet locks	60
Specialist	13
Storage	59
Sub-D male connector	65
Switching cabinet	60
Synchronization	40
T	
Technical Data	71
Temperature range	16
Terms	
Definition	5
Transportation	15, 16
Type Code	21
Plug-in module	21
U	
Unpacking	15
W	
Warranty and Liability	14
WinBASS II	
BACI	41
Data record management	48
Drive management	47
Option modules G, H – configuration	42
Synchronization	40

be in motion

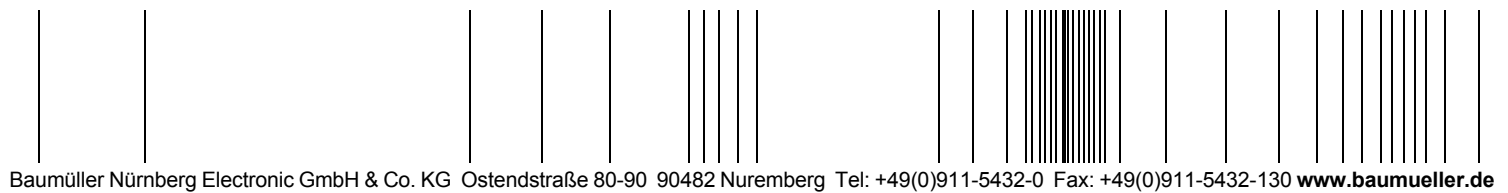

All the information in these Operating Instructions is non-binding customer information; it is subject to ongoing further development and is updated on a continuous basis by our permanent change management system. Note that all the data/numbers/information that are quoted are current values at the time of printing. This information is not legally binding for dimensioning, calculation and costing. Before using the information listed in these Operating Instructions as the basis for your own calculations and/or applications, make sure that you have the latest most current information. This means that we accept no responsibility for the accuracy of the information.