

be in motion be in motion

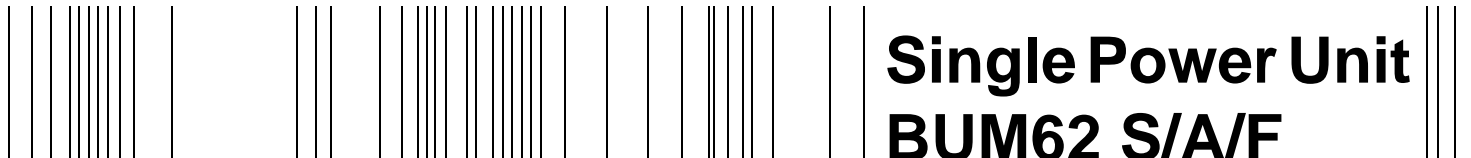

**Single Power Unit
BUM62 S/A/F**

POWER CONVERSION EQUIPMENT



Manual

E	5.01057.02
----------	------------



Title	Manual (unsigned declaration of conformity/manufacturer)
Product	Single Power Unit BUM62 S/A/F
Version	5.01057.02
Status	01-22-2007
Part No.	408553
Copyright	<p>These operating instructions may be copied by the owner in any quantity but only for internal use. For other purposes these operating instructions and extracts thereof must not be copied or reproduced.</p> <p>Use and disclosure of information contained in these operating instructions are not permitted.</p> <p>Designations and company marks contained in these operating instructions may be brand names, the use of which by third parties for their own purposes may violate the rights of the holders.</p>
Obligatory	<p>These operating instructions are part of the equipment/machine. These operating instructions must be available to the operator at all times and must be in a legible condition. If the equipment/machine is sold or moved to a different location these operating instructions must be passed on by the owner together with the equipment/machine.</p> <p>After any sale of the equipment/machine this original and all copies must be handed over to the buyer. After disposal or any other end of use this original and all copies must be destroyed.</p> <p>When the present operating instructions are handed over, corresponding sets of operating instructions of a previous version are automatically invalidated. Please notice that specifications/data/information are current values according to the printing date. These statements are not legally binding according to the measurement, computation and calculations.</p> <p>Baumüller Nürnberg GmbH reserves the right, in developing its products further, to change the technical specifications and the handling of the products concerned without prior notice.</p> <p>No liability can be accepted concerning the correctness of the operating instructions unless otherwise specified in the General Conditions of Sale and Delivery.</p>
Manufacturer	Baumüller Nürnberg GmbH Ostendstr. 80 - 90 D-90482 Nürnberg Germany Tel. +49 9 11 54 32 - 0 Fax: +49 9 11 54 32 - 1 30 www.baumueller.de



Table of contents

1	Introduction	7
1.1	First steps	7
1.2	Used terms	7
1.3	Responsibility and liability	8
1.3.1	Observing the safety notes and safety instructions	8
1.3.2	Dangers when handling this device	8
1.3.3	Warranty and Liability	9
2	Fundamental safety instructions	11
2.1	Safety notes and instructions	11
2.1.1	Structure of a safety note	12
2.1.2	Danger warnings, which are used	13
2.1.2.1	Safety notes against personal injuries	13
2.1.2.2	Safety notes against damage to property	16
2.1.2.3	Mandatory-signs, which are used	17
2.2	Information sign	18
2.3	Appropriate use	18
2.4	Inappropriate use	19
2.5	Personnel training	20
2.6	Structural changing of the device	20
2.7	Disposal of the device	20
2.8	Fire fighting	20
3	Packing and Transportation	21
3.1	Transportation	21
3.2	Unpacking	21
3.3	Dispose packing	22
3.4	To be considered by transportation	22
4	Description of the device	23
4.1	Versions	24
4.2	Overview of dangerous areas	25
4.3	Marking of the machine - type key	26
4.4	Block diagram	27
4.5	Block diagram BUM 62-70/200	28
5	Mounting	29
5.1	Danger areas at mounting	29
5.2	Mounting steps	30
5.2.1	Select control cabinet	30
5.2.1.1	Mounting space - dimensional drawings	31
5.3	Creating of drilling/threads	33
5.4	Mounting the unit	35
5.4.1	Mount BUM62 standard	35
5.4.2	BUM62 mount through-hole version A/F	37
5.4.2.1	Coolant BUM62 F	39
5.4.2.2	Connecting BUM62F to coolant circulation	40



Table of contents

6	Installation	41
6.1	General safety notes	41
6.1.1	Voltage check	43
6.2	Danger areas at the installation	44
6.3	Requirements to the electrical mains	44
6.4	Cable requirements	45
6.5	Connection	46
6.5.1	Power connections	46
6.5.2	Power connections BUM 62 S/A/F	47
6.5.3	Power connections BUM 62-70/200	48
6.5.4	Control connections	50
6.5.4.2	Control connection X99AB	53
6.5.4.3	Safety relay X68 (optional)	54
6.5.4.4	DC link quick discharge X90	56
6.6	Fuses of the device	57
6.7	Requirements on the laying (EMC instructions)	57
6.7.1	EMC regulation (EMVG)	57
6.7.2	Measures for EMC-assurance	57
6.7.2.1	Cabling	58
6.7.2.2	Grounding	60
6.7.2.3	Screening	61
6.7.2.4	Filtering	62
6.7.2.5	Filter mounting	62
6.7.2.6	Leakage currents	62
6.8	Connection diagram	63
6.9	Screwing in accordance with UL	67
7	Commissioning	69
7.1	Requirements to the executing personnel	69
7.2	Checking the mounting	70
7.3	Checking the installation	70
7.4	Checking the safety devices	71
7.5	Procedure of commissioning	71
8	Operation	73
8.1	Safety instructions	73
8.2	Monitoring functions and its messages	73
8.2.1	Monitoring functions supply unit	74
8.2.2	Monitoring functions motor-sided power unit	74
8.3	Ready-to-operate	75
8.4	Monitoring functions	77
8.4.1	Monitoring functions of the supply unit	78
8.4.2	Monitoring functions motor-sided power unit	80
8.4.3	Messages via LEDs	82
8.4.4	Messages via relay contacts	83



9	Maintenance	85
9.1	Inspection intervals	85
10	Repair	87
11	Shutdown, storage	89
11.1	Requirements to the executing personnel	89
11.2	Safety instructions	89
11.3	Shutdown	90
11.4	Demounting	90
11.5	Storage conditions	90
11.6	Maintenance during storage	90
11.7	Recommissioning	90
12	Disposal	91
12.1	Safety instructions	91
12.2	Requirements to the executing personnel	91
12.3	Disposal instructions	92
12.3.1	Modules	92
12.4	Recycling plants/offices	93
Appendix A - Abbreviations		95
Appendix B - Accessories		97
B.1	Connector	97
B.2	Fuse	98
B.2.1	Full-range fuses gR, gRL, gR/gS, gGR (device and cable), model NH	98
B.2.2	Semiconductors aR (device), model NH	99
B.3	EMC accessories	99
Appendix C -		
Declaration of conformity / manufacturer / UL-certification		101
C.1	What is an EU directive?	101
C.2	What the CE symbol indicates	101
C.3	Definition of the term Declaration of Conformity	102
C.4	Definition of the term Declaration by Manufacturer	102
C.5	Declaration of conformity	103
C.6	Declaration by manufacturer	104
C.7	UL certification	105
Appendix D - Technical data		107
D.1	Requirements on the power supply	108
D.2	Required environmental conditions	109
D.3	Electrical data	111
D.4	Fuse protection	113
D.5	BUM62 S - non-electrical data	113
D.6	BUM62 A - non-electrical data	113
D.7	BUM62 F - non-electrical data	113
D.8	Circuit mains - device	114



Table of contents

D.9	Cable control voltage supply/signals	114
D.10	Cables device-motor	114
D.11	Electric motor, which has to be connected	114
Appendix E - Safety relay		115
E.1	Methods to avoid an unexpected starting	115
E.2	Safety categories	117
E.3	The safety relay	117
E.4	Application example for machine of category 3	119
E.5	Application example for machine of category 4	121
E.6	Durability	122
Table of figures		123
Index		125

1

INTRODUCTION

In this chapter we describe the first steps, which have to be done after you have received the device. We define terms, which are continuously used throughout this manual. We give instructions, what should be taken into consideration when handling this device. μ

1.1 First steps

- 1 Check delivery, see [►Packing and Transportation◄](#) from page 21.
- 2 Forward all data, which was delivered to the responsible places in your company.
- 3 Provide capable personnel for mounting and commissioning.
- 4 Hand over this manual to the personnel and assure, that in particular the safety instructions, which are stated here are understood and followed.

1.2 Used terms

In this manual we will also use the term 'device' for the Baumüller-product 'Single Power Unit'. A list of the abbreviations which are used are to be found in [►Appendix A - Abbreviations◄](#) from page 95.

1.3 Responsibility and liability

To be able to work with this device in accordance with the safety requirements, you must be familiar with and observe the safety notes and safety instructions in this manual.

1.3.1 Observing the safety notes and safety instructions

In this manual we use visually unified safety instructions, which are intended to prevent from personal injury or damage to property.



WARNING

The following **may occur**, if you disregard these safety notes:

- serious personal injury
- death

All persons, who work with this device, must know and regard the safety notes and the safety instructions in this manual.

Apart from this, any and all persons who work on this device must additionally know and regard to all regulations and instructions, that are valid at the location.

1.3.2 Dangers when handling this device

The device 'Single Power Unit' was developed and manufactured according to the state-of-the-art technology and in compliance with the valid regulations and standards. Nevertheless, dangers can arise during use. An overview of possible dangers is to be found in chapter [▶Fundamental safety instructions◀](#) from page 11.

We will also warn you of acute dangers at the appropriate locations in this manual.

1.3.3 Warranty and Liability

The 'General Conditions of Sale and Conditions of Delivery' of Baumüller Nürnberg GmbH are generally valid. These will have been available to you since the conclusion of the contract at the latest. Warranty- and liability claims against Baumüller Nürnberg GmbH are excluded if in particular one or more of the causes listed in has/have caused the damage.

- You disregarded the notes in this manual.
- The device has not been specifically applied as a converter in order to control a motor.
- The device has been
 - mounting incorrect,
 - connected incorrectly,
 - commissioning incorrect,
 - operated incorrectly,
 - mounted, connected, commissioned, operated and/or maintained by not qualified or inadequately qualified personnel,
 - inappropriately or not maintained (also consider the descriptions of the components),
 - overloaded,
- operated
 - with defective safety devices,
 - with incorrectly mounted safety devices or without safety devices,
 - with non-functional safety- and protection devices,
 - outside the specified environmental conditions.
- You have modified the device.
- You have insufficiently monitored the parts, which are subject to a wearing.
- You have improperly carried out a repair.
- You have combined the device with improper products, which are not enabled for devices described in this manual.
- You have combined the device with faulty and/or faulty documented products of other manufacturers.
- The device has been operated in an explosive environment.

2

FUNDAMENTAL SAFETY INSTRUCTIONS

We have designed and manufactured each Baumüller device in accordance with the strictest safety regulations. Nevertheless the work with the device can be dangerous.

In this chapter we describe the dangers, that can arise when working with the Baumüller-device. Dangers we point up with symbols (icons). All symbols that are used in this manual are listed and explained.

How you can protect yourself against the single dangers in the concrete case, we will not explain in this chapter. In this chapter we inform you only about general safety precautions. Concrete protective measures we will always give directly in the subsequent chapters after the note to the danger.

2.1 Safety notes and instructions



The safety notes are showing you the dangers, which can lead to injury or even to death.

Always follow the safety notes given in this manual.

2.1 Safety notes and instructions

Dangers are always divided into three danger categories. Each danger class is identified by one of the following signal words:

DANGER

- considerable damage to property • serious personal injury • death **will** occur

WARNING

- considerable damage to property • serious personal injury • death - **can** occur

CAUTION

- light to medium personal injury or
- environmental pollution or
- damage to property - **can** occur

2.1.1 Structure of a safety note

The following two examples show how safety note is structured in principle. A triangle is used, if there is a danger against persons. If the triangle is displaced by a circle, the safety notes only refer to damages to property.



A triangle shows if persons are in danger

The color of the border shows, how great the danger is - the darker the color the greater the danger is.



The icon in the square describes the danger.

The color of the border shows, how great the danger is - the darker the color the greater the danger is. (the square is dashed, because not at every safety note the danger is demonstrated with an icon)



The icon in the circle represents an instruction. Users must observe this command.

(the circle is dashed, because not at every safety note a command is existent as icon)



The circle shows that there is a risk of damage to property.



The icon in the square describes the danger.

The color of the border shows, how great the danger is - the darker the color the greater the danger is. (the square is dashed, because not at every safety note the danger is demonstrated with an icon)

The text next to the icons is structured as follows:

HERE IS THE SIGNAL WORD, WHICH SHOWS THE LEVEL OF THE DANGER



Here we indicate whether one or more of the below-mentioned results occur, if you do not observe this warning.

- here we describe the possible consequences. The worst result is always at the extreme right.

Here we describe the danger.

Here we describe, what you can do, to avoid the danger.

2.1.2 Danger warnings, which are used

If there is a triangular figure of danger in front of a signal word:  or  or , then the safety information refers to personal injury.

If there is a round danger sign in front of a signal word:  the safety information then refers to damage to property

2.1.2.1 Safety notes against personal injuries

In order to differentiate optically we use for every class of safety notes an own bordering for the triangular danger information and for the square pictographs.

For the danger class **DANGER** we use the danger sign . We use the following safety notes of this danger class in this manual.

DANGER



The following **will occur**, if you disregard this safety information:

- serious personal injury • death



*The danger is: **electricity**. If necessary, here the danger is described more exact.*

Here we describe, what you can do, to avoid the danger.

DANGER



The following **will occur**, if you disregard this safety information:

- serious personal injury • death



*The danger is: **mechanical effects**. If necessary, here the danger is described more exact.*

Here we describe, what you can do, to avoid the danger.

2.1 Safety notes and instructions

For the danger class (WARNING) we use the danger sign . We use the following safety notes of this danger class in this manual.



WARNING

The following **can occur**, if you disregard this warning instruction:

- serious personal injury • death

*The danger is: **electricity**. If necessary, here the danger is described more exact.*

Here we describe, what you can do, to avoid the danger.



WARNING

The following **can occur**, if you disregard this warning instruction:

- serious personal injury • death

*The danger is: **mechanical effects**. If necessary, here the danger is described more exact.*

Here we describe, what you can do, to avoid the danger.



WARNING

The following **can occur**, if you disregard this warning instruction:

- serious personal injury • death

*The danger is: **conductive fluid in connection with electricity**. If necessary, here the danger is described more exact.*

Here we describe, what you can do, to avoid the danger.



WARNING

The following **can occur**, if you disregard this warning instruction:

- serious personal injury • death

*The danger is: **electromagnetic radiation**. If necessary, here the danger is described more exact.*

Here we describe, what you can do, to avoid the danger.



WARNING



The following **can occur**, if you disregard this warning instruction:

- serious personal injury • death



*The danger is: **Cooling liquid**. If necessary, here the danger is described more exact.*

Here we describe, what you can do, to avoid the danger.

For the danger class **CAUTION** against danger of personal injury or environmental pollution we use the danger sign . We use the following safety notes of this danger class in this manual.

CAUTION



The following **can occur**, if you disregard this warning instruction:

- minor to medium personal injury.



*The danger is: **hot surface**. If necessary, here the danger is described more exact.*

Here we describe, what you can do, to avoid the danger.

CAUTION



The following **can occur**, if you disregard this warning instruction:

- minor to medium personal injury.



*The danger is: **sharp edges**. If necessary, here the danger is described more exact.*

Here we describe, what you can do, to avoid the danger.

CAUTION



The following **can occur**, if you disregard this warning instruction:

- minor to medium personal injury.



*The danger is: **rotating parts**. If necessary, here the danger is described more exact.*

Here we describe, what you can do, to avoid the danger.

2.1 Safety notes and instructions



CAUTION

The following **can occur**, if you disregard this warning instruction:

- minor to medium personal injury.

*The danger is: **noise**. If necessary, here the danger is described more exact.*

Here we describe, what you can do, to avoid the danger.



CAUTION

The following **can occur**, if you disregard this warning instruction:

- minor to medium personal injury.

*The danger is: **Slipping danger due to liquid**. If necessary, here the danger is described more exact.*

Here we describe, what you can do, to avoid the danger.



CAUTION

The following **can occur**, if you disregard this warning instruction:

- Environmental pollution

*The danger is: **incorrect disposal**. If necessary, here the danger is described more exact.*

Here we describe, what you can do, to avoid the danger.

2.1.2.2 Safety notes against damage to property

If there is a round danger sign in front of a signal word: ⓘ the safety information then refers to damage to property



CAUTION

The following **can occur**, if you disregard this warning instruction:

- Property damage

*The danger is: **electrostatic discharge**. If necessary, here the danger is described more exact.*

Here we describe, what you can do, to avoid the danger.



CAUTION

The following **can occur**, if you disregard this warning instruction:

- Property damage

*The danger is: **Damage of the coolant hose**. If necessary, here the danger is described more exact.*

Here we describe, what you can do, to avoid the danger.



2.1.2.3 Mandatory-signs, which are used



Use ear protection



Use the following fire fighting devices:
ABC-Pulver



Wear safety gloves



Wear safety shoes

2.2 Information sign



NOTE

This note is a particularly important information.

2.3 Appropriate use

You must always use the device appropriately. Some important information is listed below. The notes stated below shall give you a feeling of the specified application of the device. We do not raise any claim to the sufficiency of the notes stated below - obey all instructions given in this operating instruction.

- Configure the application in such a way, that you always operate the device within its specification.
- Make sure, that only qualified personnel work with/at this device.
- Mount this device only at an adequate carrying wall.
- Install this device in the way as it is described in the manual.
- Make sure, that the mains always applies to the predetermined specifications.
- Operate the device only, if it is technically perfect.
- Always operate the device in an area as it is instructed in the 'Technical data'.
- Always operate the device in serialized status.
Due to safety reasons you may not rebuild the device.
- Consider all instructions referring to this, if you intend to store the device.

You are using the device according to the terms, as soon as you regard all notes and information in this operating manual.

2.4 Inappropriate use

In the following we are listing some examples of inappropriate use. The notes below should give you an idea of what is meant by inappropriate use of the plug-in module. However, we cannot list all possible cases of inappropriate use here. All uses, in which the instructions of this manual are disregarded are inappropriate and therewith forbidden, especially in the following cases:

- You disregarded the notes in this manual.
- The device has not been specifically applied as a converter in order to control a motor.
- The device has been
 - mounting incorrect,
 - connected incorrectly,
 - commissioning incorrect,
 - operated incorrectly,
 - mounted, connected, commissioned, operated and/or maintained by not qualified or inadequately qualified personnel,
 - inappropriately or not maintained (also consider the descriptions of the components),
 - overloaded,
- operated
 - with defective safety devices,
 - with incorrectly mounted safety devices or without safety devices,
 - with non-functional safety- and protection devices,
 - outside the specified environmental conditions.
- You have modified the device.
- You have insufficiently monitored the parts, which are subject to a wearing.
- You have improperly carried out a repair.
- You have combined the device with improper products, which are not enabled for devices described in this manual.
- You have combined the device with faulty and/or faulty documented products of other manufacturers.
- The device has been operated in an explosive environment.

2.5 Personnel training



Devices of Baumüller Nürnberg GmbH may only be mounted, installed, operated and maintained by qualified personnel.

Qualified
Personnel

Qualified personnel are persons, who have been instructed by the responsible person, based on their training, experience, the instructions they were given as well as their knowledge about relevant standards and instructions, knowledge of the accident prevention instructions and of the company, to execute the necessary operations and thereby are able to recognize and avoid the dangers which could happen.

2.6 Structural changing of the device

Structural changing are forbidden without written agreement of Baumüller Nürnberg GmbH.

2.7 Disposal of the device

The disposal of the device is described in [►Disposal◄](#) from page 91.

2.8 Fire fighting



WARNING

The following **may occur**, if you disregard these safety notes:

- serious personal injury • death

*The danger is: **Electricity when using a conductive fire fighting appliance.***



Use the following fire fighting devices:

ABC-Pulver

3

PACKING AND TRANSPORTATION

Before shipment we have packed every Baumüller device in such a way, that a damage during transportation is nearly impossible.

3.1 Transportation

The devices are packed according to the order in the manufacturing company.

- ▶ Avoid strong transportation vibrations and severe hits, e. g. when setting down.

3.2 Unpacking

After receipt of the device, which is still packed:

- ▶ Check, if transportation damages are visible!

If so:

- ▶ Immediately complain to the deliverer. Let the claim be confirmed in writing and immediately contact the substitution of Baumüller Nürnberg GmbH, which is in charge for your company.

If there is no transportation damage recognizable:

- ▶ Open the packing of the device.
- ▶ Check the scope of supply by means of the delivery note.

The scope of supply is:

- Produkt
- This operating instruction inclusively the copy of the declaration of conformity/declaration of manufacturer
- Enclosed is fastening material
- ▶ claim at the Baumüller substitution, which is in charge, in case there is a recognizable transportation damage or if the delivery is not complete.

3.3 Dispose packing



WARNING

The following **may occur**, if you disregard these safety notes:

- serious personal injury
- death



*The danger is: **electricity**.*

Do not operate the device, if you have recognized a transportation damage or if you assume this.

In this case immediately contact Baumüller Nürnberg GmbH.

3.3 Dispose packing

The packing is made of cardboard, plastics, metal parts, corrugated cardboard and/or wood.

- Regard the local disposal instructions, in case you dispose the packing.

3.4 To be considered by transportation

For the first transportation of the device, the device was packed in the manufacturer company. In case you transport the device, assure, that the following conditions are fulfilled during the whole transportation:

- 2 K 3 (climatic category)
- - 30 °C bis + 70 °C (temperature range)
- max. 1 g (vibration, shock, repetitive shock)

DESCRIPTION OF THE DEVICE

This unit is a power converter for power range up to 50 kW. This unit converts power taken from the mains (line-sided supply unit) and supplies the connected electrical motor, which is connected to this device with converted power (motor-sided power unit). For this control only plug-in controllers of Baumüller Nürnberg GmbH must be used.

- BUS 6 V controller
- BUS 6 M controller

A separate description for the controller with the applicable characteristics and technical data is available.

Dependant of the settings of the controller, which is used you are able to operate asynchronous- as well as synchronous motors with different encoder systems at the single power units BUM62 S/A/F.



NOTE

Do not use this device in residential areas (see EN 61800-3, 6.4.2.1), because the device can cause RF interferences in residential areas.

4.1 Versions

The single power unit BUM62 S/A/F is available in versions, which differ in method of cooling (S/A/F):

- Control cabinet device **S** (ventilation within the control cabinet)
- Through-hole version **A** (air ventilation outside the control cabinet)
- Through-hole version **F** (water cooler outside the control cabinet)

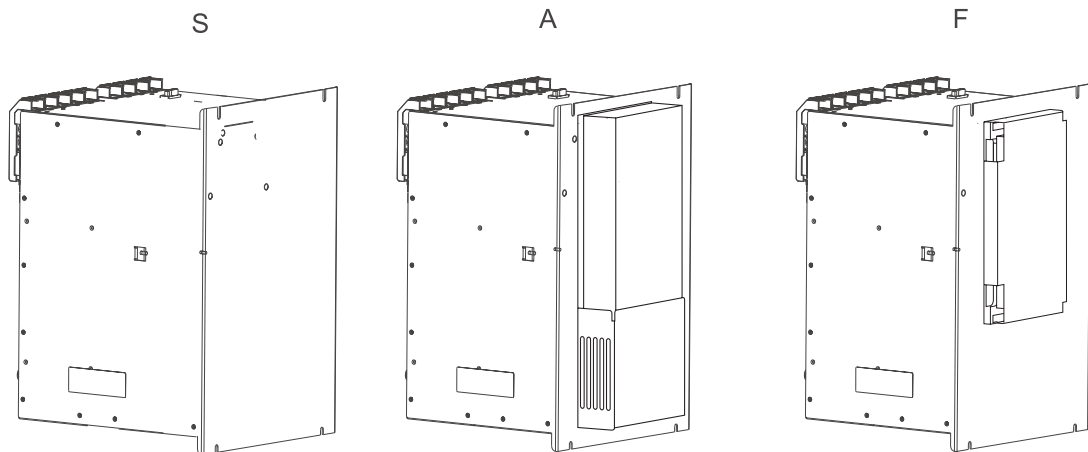

Figure 1: Cooling versions

4.2 Overview of dangerous areas

The following overview shows the existing danger areas on the particular device. Use this survey for an overview of the existing danger areas, if you incorporate into the handling of this device.

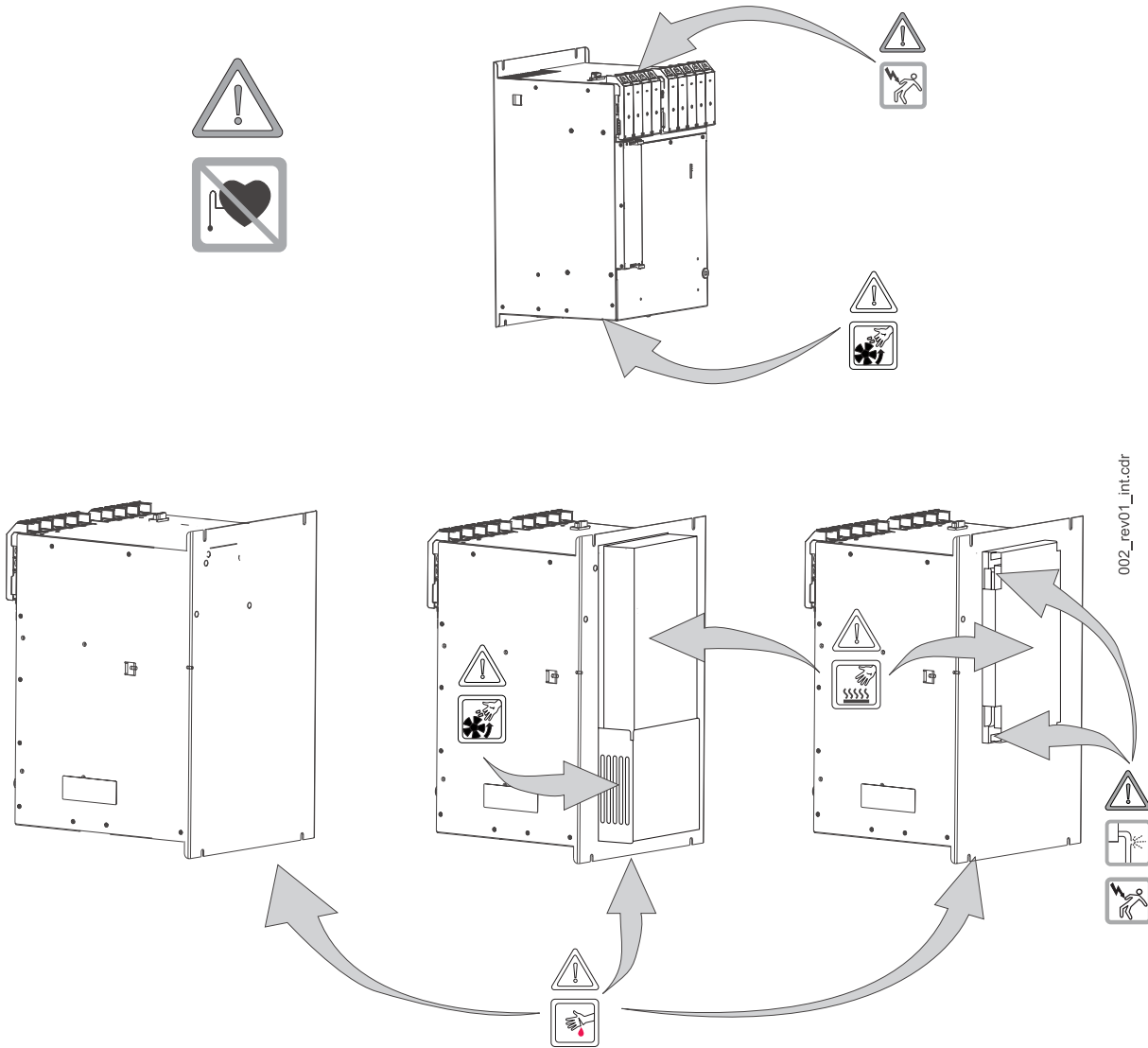

Figure 2: Danger areas

4.3 Marking of the machine - type key

4.3 Marking of the machine - type key

On the label (position on the inner side, see following figure) the type key and the serial number of the device are specified.

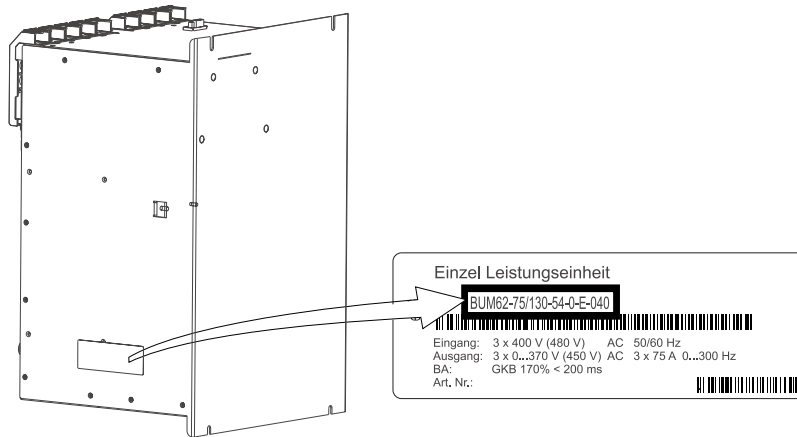

Figure 3: Type key

BUM62XX - XXX/XXX - XX - X - X - XXX Baumüller converter single power unit

BUM62XX - XXX/XXX - XX - X - X - XXX Series of type

BUM62XX - XXX/XXX - XX - X - X - XXX Size

BUM62X - XXX/XXX - XX - X - X - XXX Cooling type

S or no identification code: air-cooled with air supply and air outlet in the control cabinet
 A: air-cooled with air supply and air outlet outside the control cabinet
 F: water-cooled with water cooler outside the control cabinet

BUM62X - XXX/XXX - XX - X - X - XXX Output rated current in ampere at 40° C environmental- and coolant temperature and 4kHz cycle frequency

BUM62X - XXX/XXX - XX - X - X - XXX Output peak current in ampere at 40° C environmental- and coolant temperature and 4 kHz cycle frequency, at $t \leq 2$ min. or $t < 1$ s, according to device, also see [►Appendix D - Technical data◀](#) from page 107

BUM62X - XXX/XXX - XX - X - X - XXX Rated DC link voltage x 10 [V]

BUM62X - XXX/XXX - XX - X - X - XXX Chopper transistor

O: without chopper transistor
 E: with chopper transistor, external resistor

BUM62X - XXX/XXX - XX - X - X - XXX Safety relay

O: without safety relay
 M: with safety relay

BUM62X - XXX/X XX - XX - X - X - XXX Development status/version

On the type plate you will find only a part of the technical data. A survey of all the technical data is to be found in [►Appendix D - Technical data◀](#) from page 107.

4.4 Block diagram

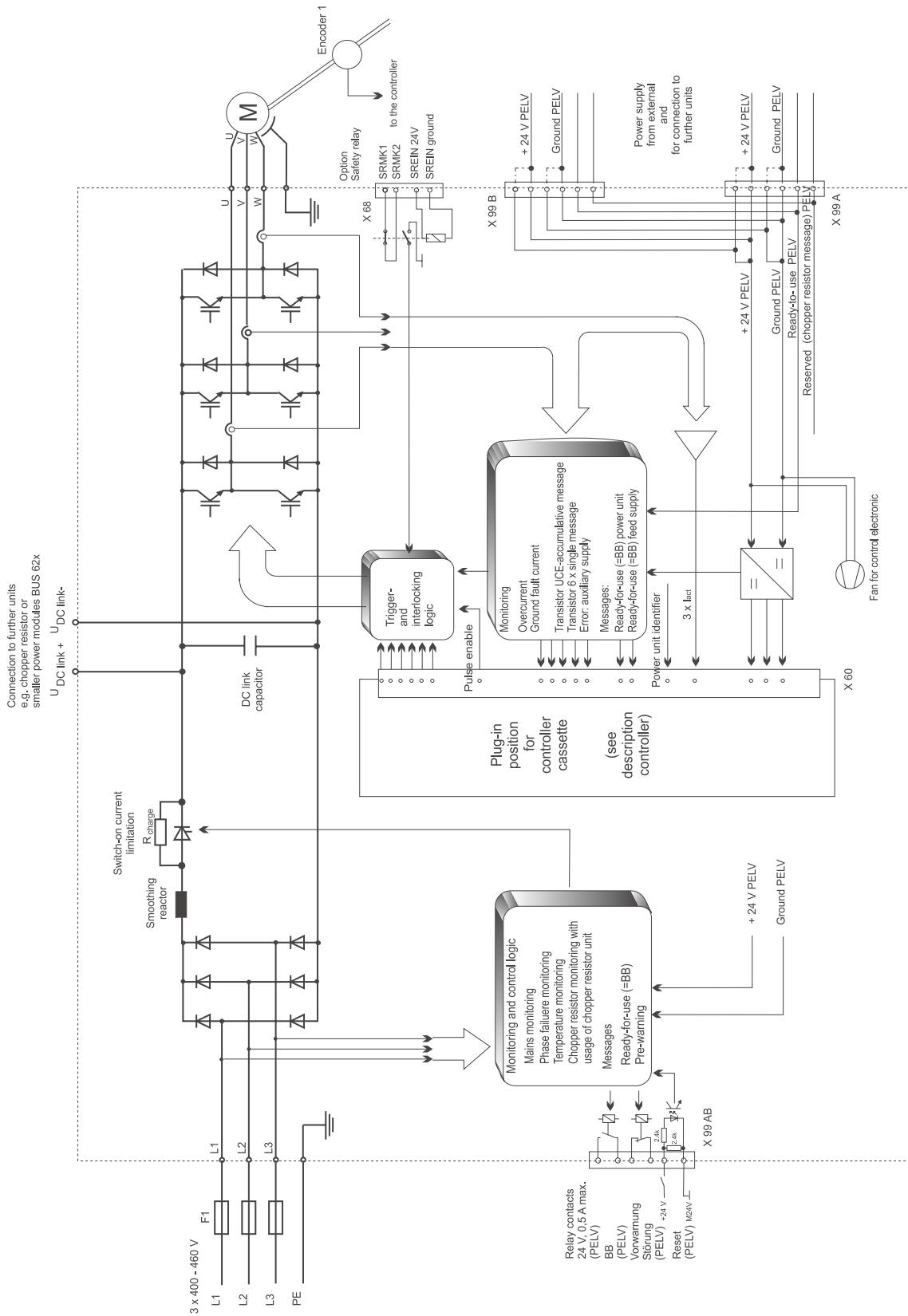

Figure 4: Block diagram BUM 62 S/A/F

4.5 Block diagram BUM 62-70/200

4.5 Block diagram BUM 62-70/200

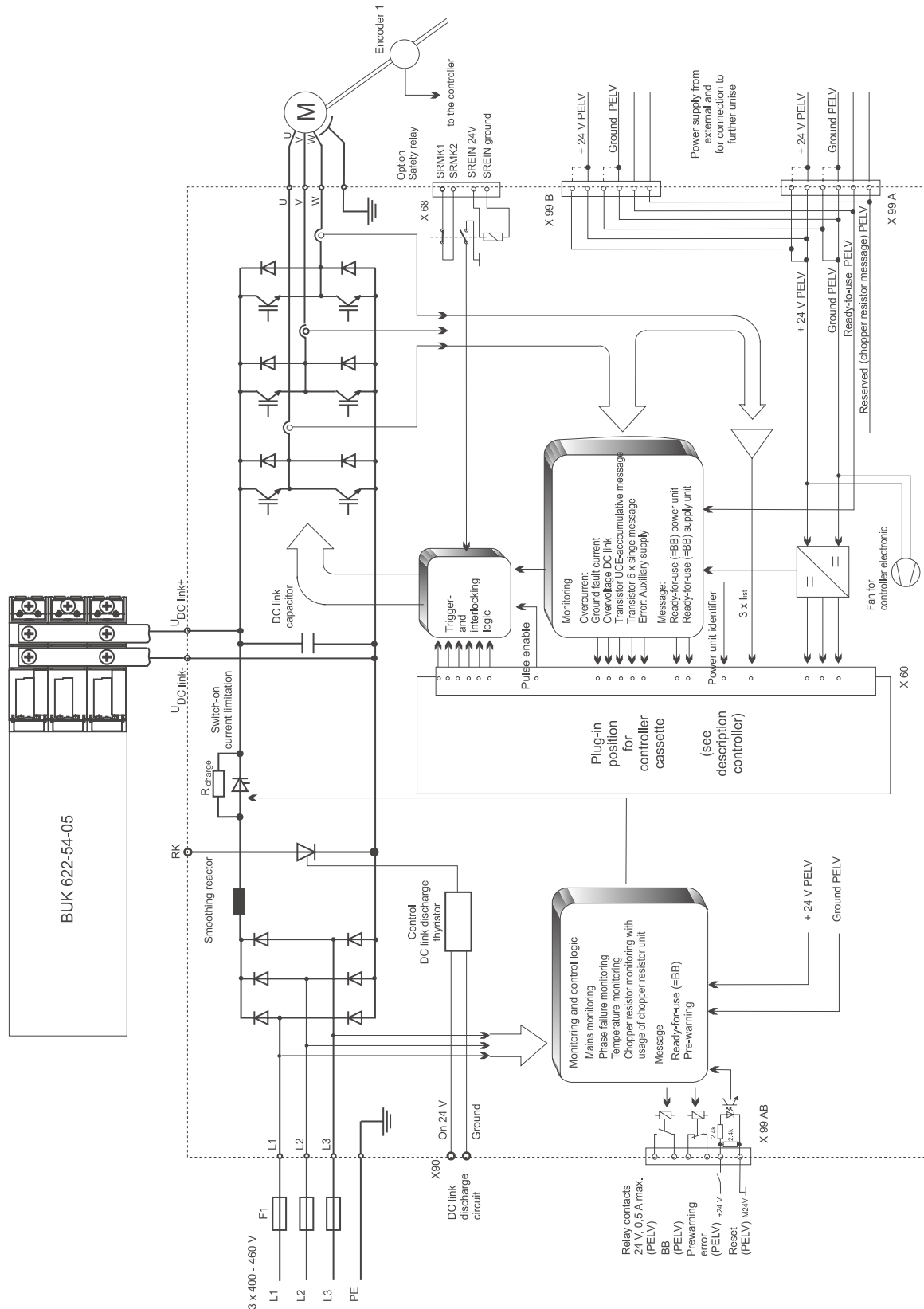

Figure 5: Block diagram BUM 62-70/200

MOUNTING

In case the units shall be mounted in an isolated electrical work shop according to EN 50178/VDE 0160, section 5.2.7, you will in addition have to take additional measures, that the requirements according to EN 50178/VDE 0160, section 5.2.4 and EN 60204-1/VDE 0113 part 1, section 6.2.2 are fulfilled.

5.1 Danger areas at mounting

The following overview shows the existing danger areas at the device, which are important for the mechanical mounting.



Use this survey only for the mechanical mounting. Dangers, which, for example, result from electricity are not shown here. Dangers, which, for example, result from electricity are shown in [▶Danger areas at the installation◀](#) on page 44.

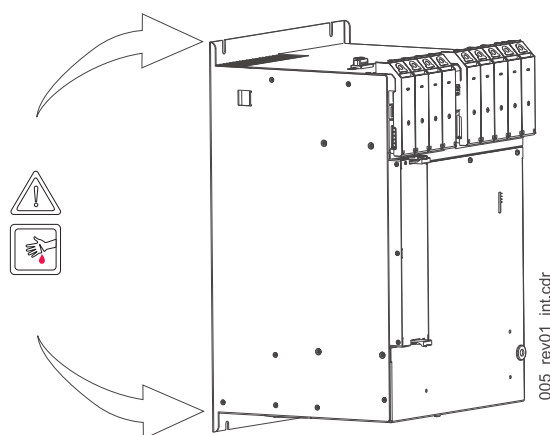

Figure 6: Danger areas at mounting

5.2 Mounting steps

The mechanical consists of the following steps:

- select the control cabinet.
- produce the drill holes/threaded holes and the cut-outs (only version A/F).
- mount the unit.
- connect the cooling circulation (only version F), check on tightness and perform a pressure test.

Additional data concerning the single steps is available in the following sections.

5.2.1 Select control cabinet

BUM62S/A/F units are build-in devices in terms of EN 50178/VDE 0160 section 5.2.6. They are intended for mounting into ordinary control cabinets, which meet the minimum requirements acc. to EN 50178/VDE 0160, section (IP 2X, eventually also IP4X acc. to EN 60529/5.1).



WARNING

The following **can occur**, if you disregard this warning instruction:

- serious personal injury • death



*The danger is: **mechanical effects**. The units weigh about 35 kg, depending on the model.*

Select a control cabinet, which can carry this weight permanently.



NOTE

In case you mount a through-hole version (F/A), the thickness of rear panel must maximum be 6 mm.

5.2.1.1 Mounting space - dimensional drawings

Use the following dimensional drawings, in order to specify mounting space in the control cabinet.



CAUTION

The following **can occur**, if you disregard this warning instruction:

- Property damage

The danger is: overheating of device.

Provide output of device waste heat. Assure, that unrestricted coolant input and -output is possible.

provide the required coolant temperature and coolant amount (see [►D.2 Required environmental conditions](#) auf Seite 109). If necessary apply an additional fan at the control cabinet.

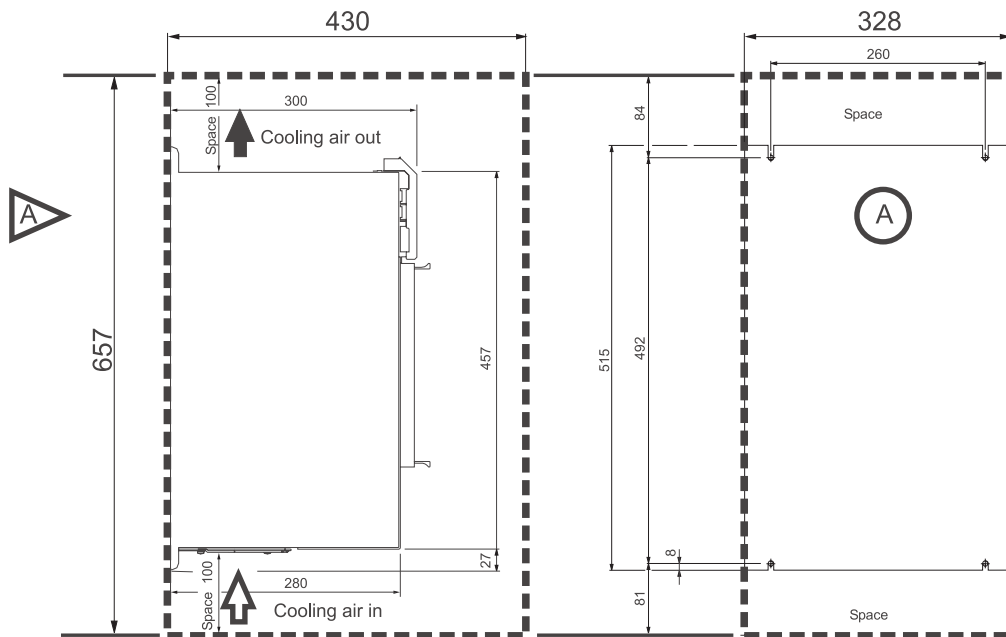

Figure 7: Dimension diagram BUM 62 standard

5.2 Mounting steps

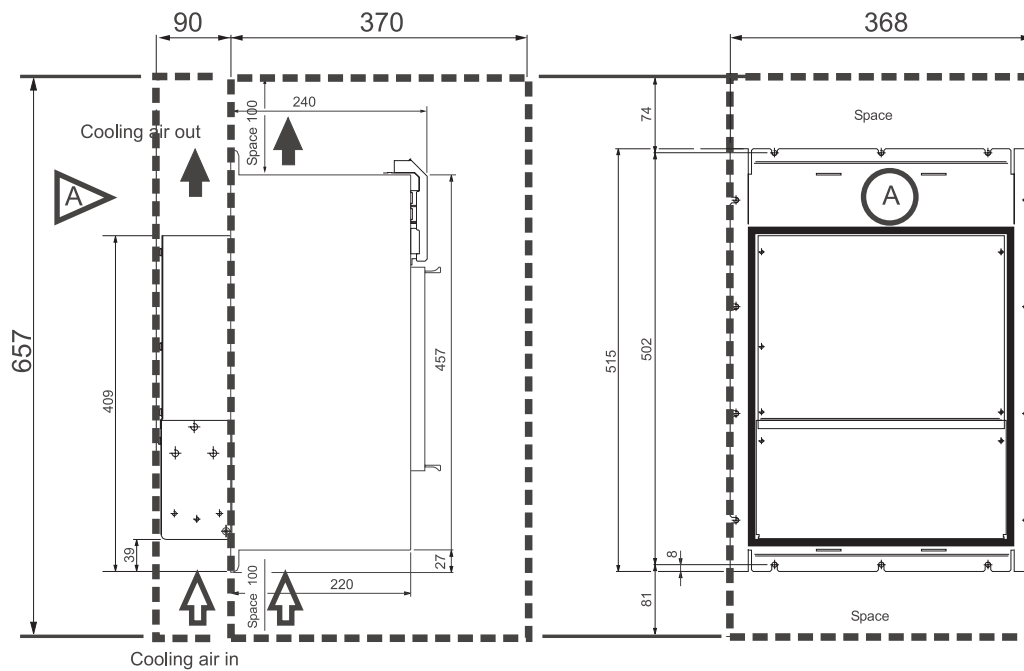

Figure 8: Dimension diagram BUM62 through-hole version A

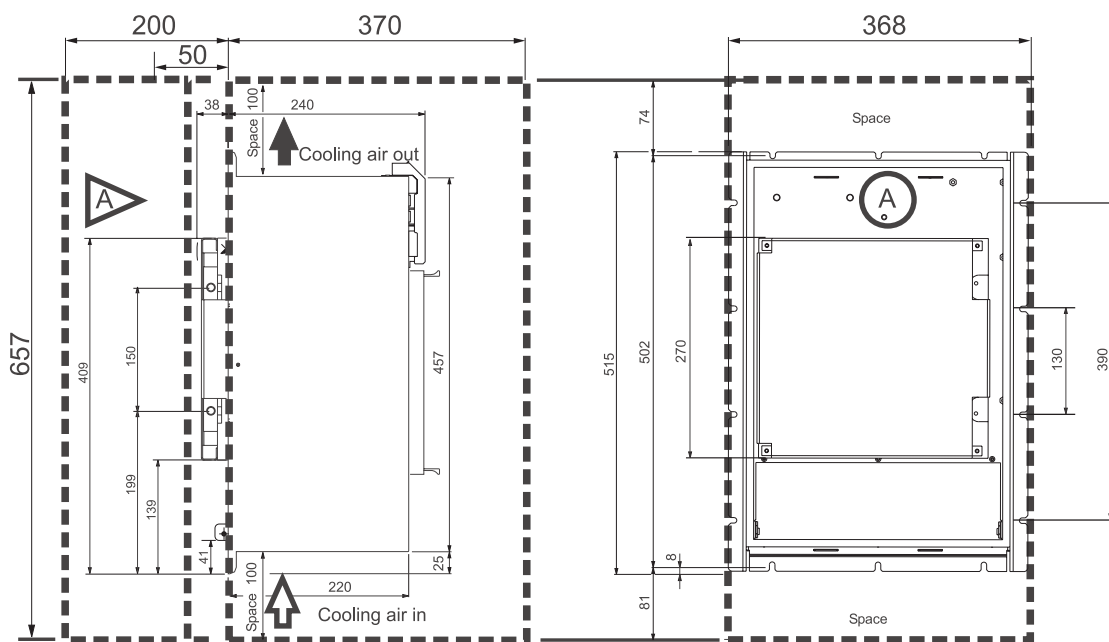

Figure 9: Dimension diagram BUM62 through-hole version F

5.3 Creating of drilling/threads

- Create drilling/thread and cut-out (only version A/F) as specified in the following drilling drawings. Thereby absolutely refer to the expansion space.

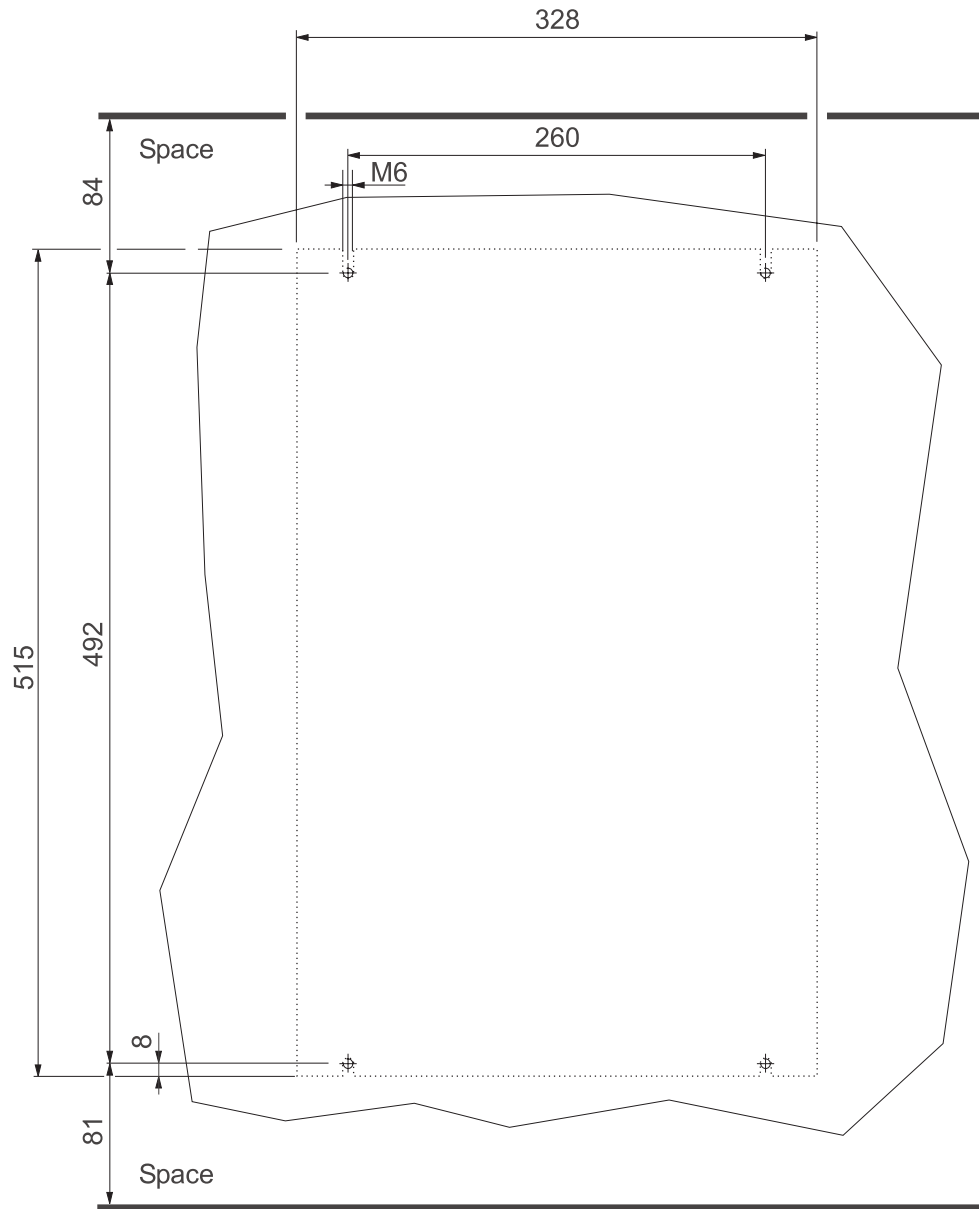

Figure 10: Drill drawing BUM 62 standard

5.3 Creating of drilling/threads

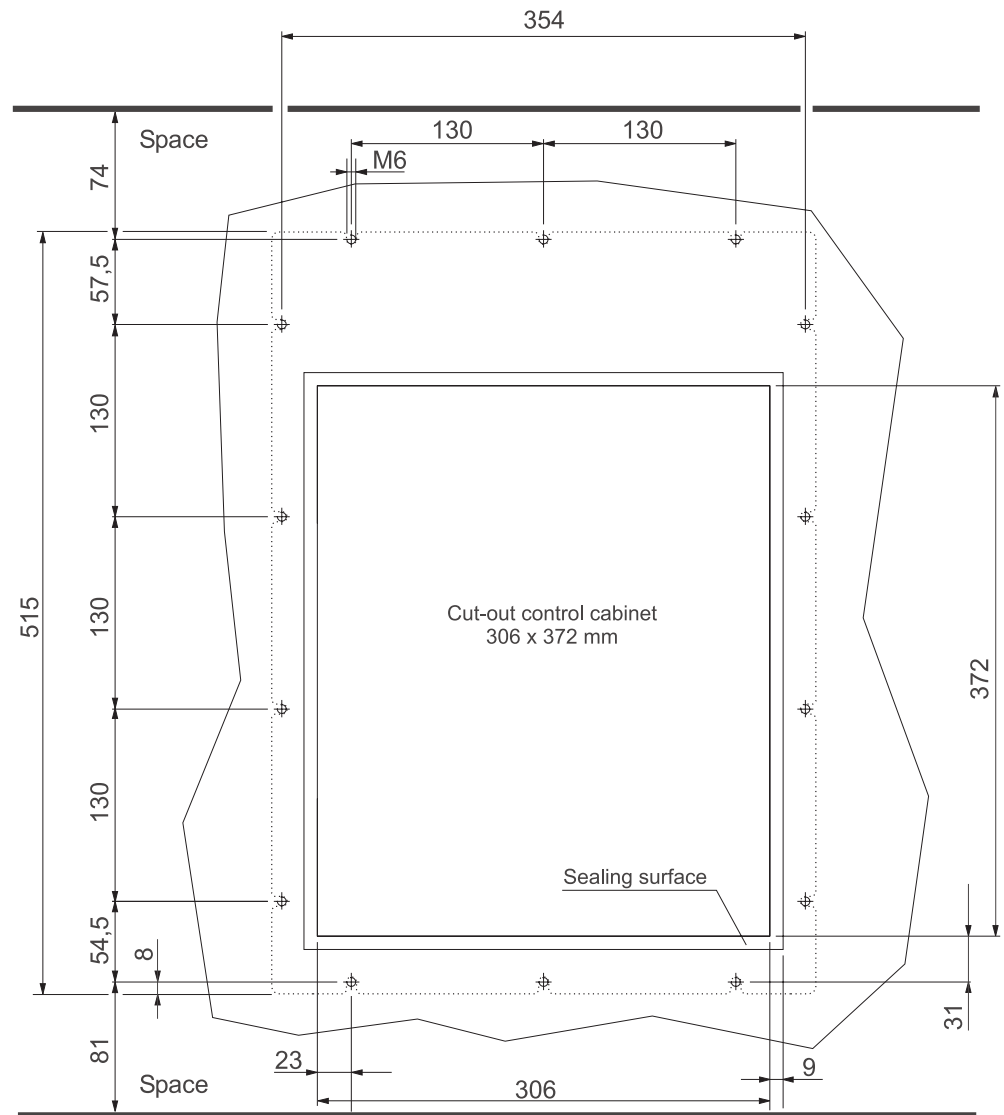

Figure 11: Drill drawing BUM 62 through-hole version A/F

5.4 Mounting the unit

- 1 Screw the rear panel of unit with the rear panel of the control cabinet together.
- 2 Mount all screws in order to assure the EMC of the unit.

5.4.1 Mount BUM62 standard

WARNING



The following **can occur**, if you disregard this warning instruction:

- serious personal injury • death



*The danger is: **conductive fluid in connection with electricity**. If cooling water escapes from a water-cooled unit within the control cabinet, the water may contact parts, which carry dangerous voltage levels.*



Assure, that it is adhered to all safety instructions which are valid for water-cooled devices that are mounted into a control cabinet.

CAUTION



The following **can occur**, if you disregard this warning instruction:

- minor to medium personal injury.



*The danger is: **sharp edges**.*

Consider the weight of unit - the unit weighs at least 35 kg.

Lift the unit only with suitable equipment and/or with the help of qualified personnel.



Wear safety gloves

5.4 Mounting the unit

Screws (A)	4 x M6			
Washers (B)	4 x (8.4 x 17)			
Mount spacing (c)	c = 3 mm			

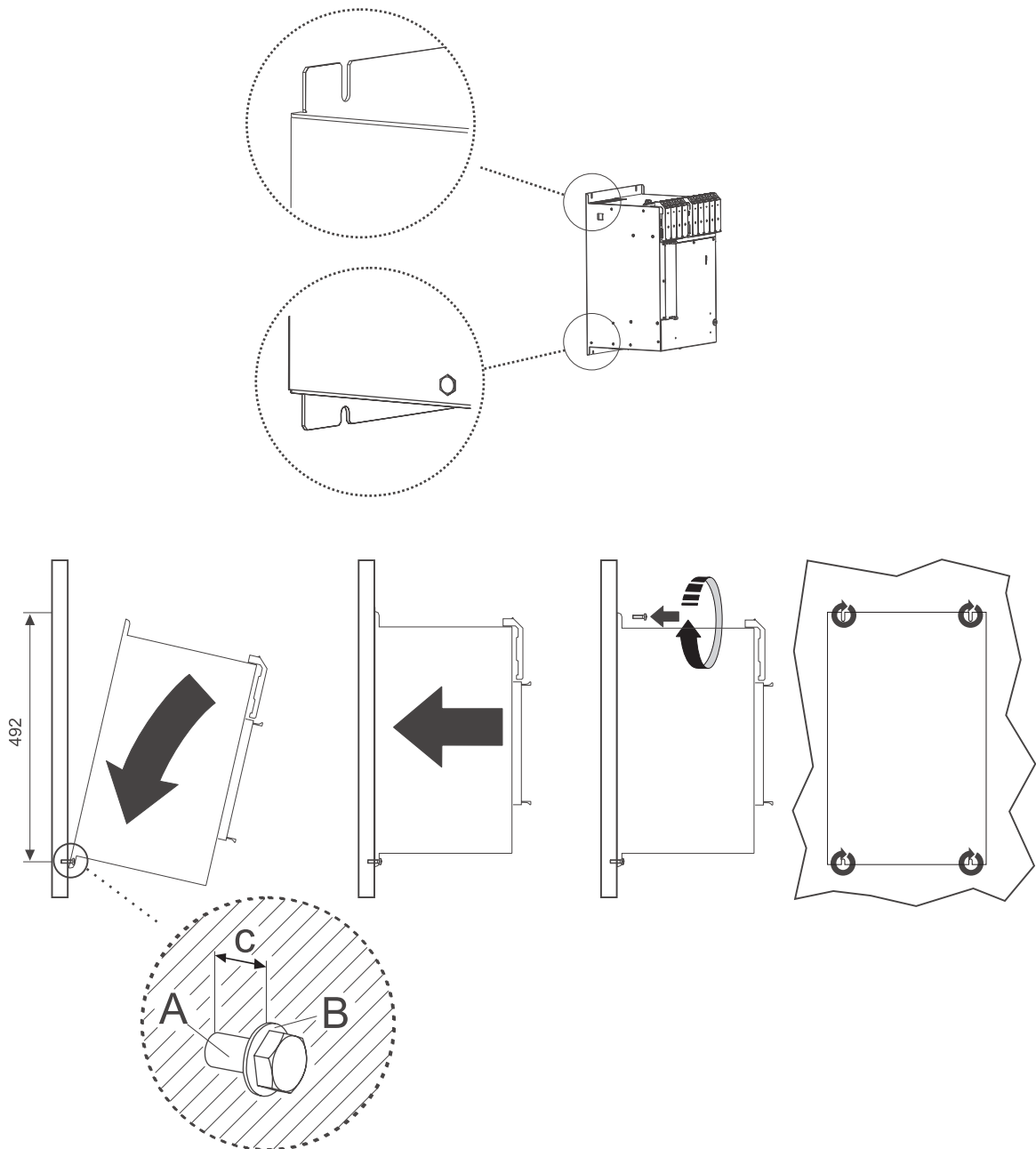

Figure 12: Mounting instruction BUM62 S

5.4.2 BUM62 mount through-hole version A/F



CAUTION

The following **can occur**, if you disregard this warning instruction:

- minor to medium personal injury.

*The danger is: **sharp edges.***

Consider the weight of unit - the unit weighs at least 35 kg.

Lift the unit only with suitable equipment and/or with the help of qualified personnel.



Wear safety gloves



WARNING

The following **can occur**, if you disregard this warning instruction:

- serious personal injury • death

*The danger is: **conductive fluid in connection with electricity.** If cooling water escapes from a water-cooled unit, it may happen, if there are faulty seals that water enters the control cabinet and may contact parts, which carry dangerous voltage levels.*

Assure, that seals at the rear side of the unit are not damaged. You may only mount the unit, if the seal is not damaged.



5.4 Mounting the unit

Screws (A)	14 x M6				
Washers	14 x (8.4 x 17)				
Seal	see accessories				

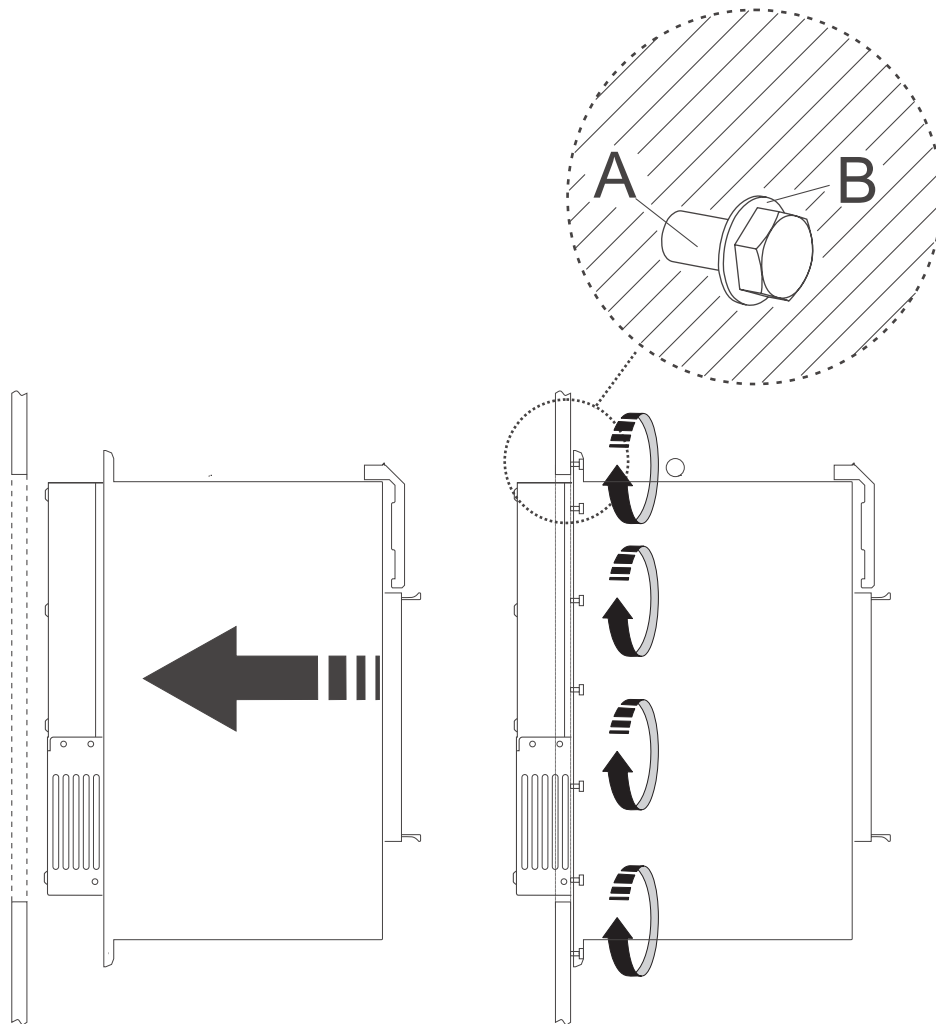

Figure 13: Mounting instruction BUM62 through-hole version A/F

5.4.2.1 Coolant BUM62 F

The coolant must meet certain requirements. The requirements the coolant must have is to be found in [►D.2 Required environmental conditions◄](#) on page 109.

WARNING



The following **can occur**, if you disregard this warning instruction:

- serious personal injury
- death



*The danger is: **conductive fluid in connection with electricity.** The heatsink can corrode and become leaky if the wrong coolant is used. If e. g. the heatsink is leaky, the cooling water can escape from the cooling circulation, into the control cabinet and can contact parts, which carry dangerous voltage levels.*



Do not mix anti corrosives!

Under all circumstances keep the mixture ratio and test the mixture ratio within the stated maintenance intervals (see [►Inspection intervals◄](#) on page 85).

Refer to the safety instructions of the anticorrosive manufacturer and the safety data sheets acc. to EU directive or the common national guidelines of the country, where the device is in operation.

For disposal of the coolant observe the water endangerment classes (WGK) supplied by the manufacturer. Since May 17, 1999 there no longer is a class 0 according to VwVwS (Administrative Regulation of Substances Hazardous to Waters). Beginning with class 1 (low hazardous to waters, Germany) the hazardous to waters increases with the upper digit. In any case disposal must be made according to instructions, the local waste water administration must be consulted. A disposal in the sewer - even thinned - is forbidden.

CAUTION



The following **can occur**, if you disregard this warning instruction:

- Property damage

*The danger is: **Damage of the cooling circulation.***

Do not use coolant lubricants from the machining processes as coolant!

Coolant circulations must be kept in a filled state using coolant-water mixtures in order to avoid corrosion at the transition between liquid and air.

Make sure, that there are no air reservoirs within the coolant circulation.

Remainders of coolant can act corrosive, lead to a lowering of the pH-value and act corrosive within the acid pH-value sector.

When exchanging or switching over from one coolant to another observe that the coolant circulation must be thoroughly rinsed with water several times.

If coolant circulations that have been filled with a coolant-water mixture must be emptied and cannot be refilled within a few days, it is essential, that they are rinsed repeatedly with water and after that be emptied completely.

5.4.2.2 Connecting BUM62F to coolant circulation

The BUM62 F devices have a pre-mounted heatsink on its reverse side. Two connections (G1/8") at the heatsink are destined for the intake and outlet of a coolant circulation system. For the connection on the customer side of the coolant circulation use connectors with an inside thread G1/8", which are screwed with the existing heatsink connections at the device together.

The heatsink connections are on the reverse side of the device.

Connection to cooling circulation:

- 1 Provide suitable connections
(Material: brass/stainless steel/plastics, thread: G1/8").
- 2 Clear internal thread of connections.
- 3 Assure, that the seals are undamaged.
- 4 Manually screw on supply cable to the existent connections and tighten with the maximum permissible torque.



CAUTION

The following **can occur**, if you disregard this warning instruction:

- Property damage

The danger is: Damage of connecting thread.

Never tighten stronger than with the maximum permissible torque 12 Nm).

- 5 Connect outlet with another connection.



NOTE

The flow direction is as desired.

- 6 Check tightness of cooling circulation.
- 7 Perform cooling circulation with the specified pressure test (12 bar).

6

INSTALLATION

In this chapter we describe the electric installation of the device. Mechanic mounting is described in chapter [▶Mounting◀](#) from page 29.

Installation exists of the following steps:

- 1 Check the requirements to the electrical mains and check if the existing mains is suitable.
- 2 Check the requirements to the electrical cables and provide the according cables.
- 3 Check the characteristics of connections and configure the cables accordingly.
- 4 Lay all cables EMC-compatible.
- 5 Is screwing necessary for UL 508C? If so, use a suitable torque spanner (see [▶Screwing in accordance with UL◀](#) on page 67).

6.1 General safety notes

The units BUM62 S/A/F are devices of protection class I accordant to HD366 S1 chapter 3.2, also see EN 50178/VDE 0160 paragraph 5.2.9.

Devices of protection class I are devices, where the protection against dangerous residual currents dependent on the base insulation and therewith contains additional safety measures. This additional protection is provided by connecting housing and other parts with the PE conductor, so that in case of failure of the base insulation no voltage remains. The insulation at these devices according to EN 50178/VDE 0160, para. 5.2.9.1 is made in the complete progress according to the base insulation at minimum. This applies to the insulation between the current circuits and the environment.

The control connections of devices have got a protective separation from the mains and are executed for the connection of PELV-/SELV circuits.

When rating clearance and creepage distances following criteria are considered:

- Degree of pollution 2 acc. to EN 50178/VDE 0160, paragraph 5.2.15.2, table 2, line 3: normally only a non-conductive pollution occurs. Any conductive pollution (for a short period or continuous) is not permitted and can lead to the destruction of the device. The customer is responsible for destructions based on pollution with conductive substance or materials.
- Overvoltage category III acc. to IEC 664-1, table 1 for clearance distances of mains circuits against its environment acc. to EN 50178/VDE 0160, paragraph 5.2.16.1.
- Rating of insulation voltage of mains circuits for TN- and TT mains 849 V acc. to EN 50178/VDE 0160, paragraph 3.64.

The devices BUM62 S/A/F are only limited to a certain level short-circuit proof in the sense of EN 50178/VDE 0160, paragraph 6.3.4.

The devices BUM62 S/A/F are not short-circuit-proof in the sense of EN 50178/VDE 0160, paragraph 6.3.4.

During operation in the converter and in the motor discharging currents always occur against ground and can result in a premature response to a connected ELCB.

WARNING



The following **can occur**, if you disregard this warning instruction:

- serious personal injury • death



*The danger is: **electricity**. At residual currents or at ground fault a direct component in the fault current can occur, which complicates or avoids the release of a higher-level ELCB.*

The connection of power unit to the mains only with the use of the ELCB is forbidden (EN 50178/VDE 0160, paragraph 5.2.11 and 5.3.2.1).

The protection against touching of the units is achieved by the mounting of the converters into conventional control cabinets, which, regarding the protection type comply with the minimum requirements acc. to EN 50178/VDE 0160, paragraph 5.2.4 and EN 60204-1, chapter 12.4.

Plastic covers on the devices, which cover the control connections, provide additional protection against accidental contact when commissioning or in case of 'occasional handling' of operator control elements, which are nearby. For the power connection additional measures must be made.

(IEC 60536-2, chapter 5.1.1, Accident Prevention Directive 'Electrical and Equipment' BGV A2).

Essential for personal protection are the safety precautions and safety instructions acc. to DIN/VDE.

**WARNING**

The following **can occur**, if you disregard this warning instruction:

- serious personal injury
- death



*The danger is: **electricity**.*

In case there are missing protective ground connections at the unit or at the motor it must be reckoned on personal injury.

Connect protective conductor. Operate units only at grounded supply systems.

Discharging time of components under voltage is > 1 min.

Before working check with suited measuring devices at components under voltage, that the parts are not voltage-carrying. Touch the parts not until you have verified yourself from the safe isolation, and if the unit and the motor are secured against switching on.

6.1.1 Voltage check

At routine test of these units a voltage check is executed acc. to EN 50178/VDE 0160, paragraph 9.4.5 by Baumüller Nürnberg GmbH.

**WARNING**

The following **can occur**, if you disregard this warning instruction:

- serious personal injury
- death



*The danger is: **electricity**.*

Subsequent checks of unit with high voltages must be executed only by Baumüller Nürnberg GmbH.

If you want to check complete control cabinet installation with high voltage, you must separate all cable connection from the Baumüller units before checking.

6.2 Danger areas at the installation

6.2 Danger areas at the installation

The following overview shows all areas at the unit, which can be dangerous at the electrical installation.

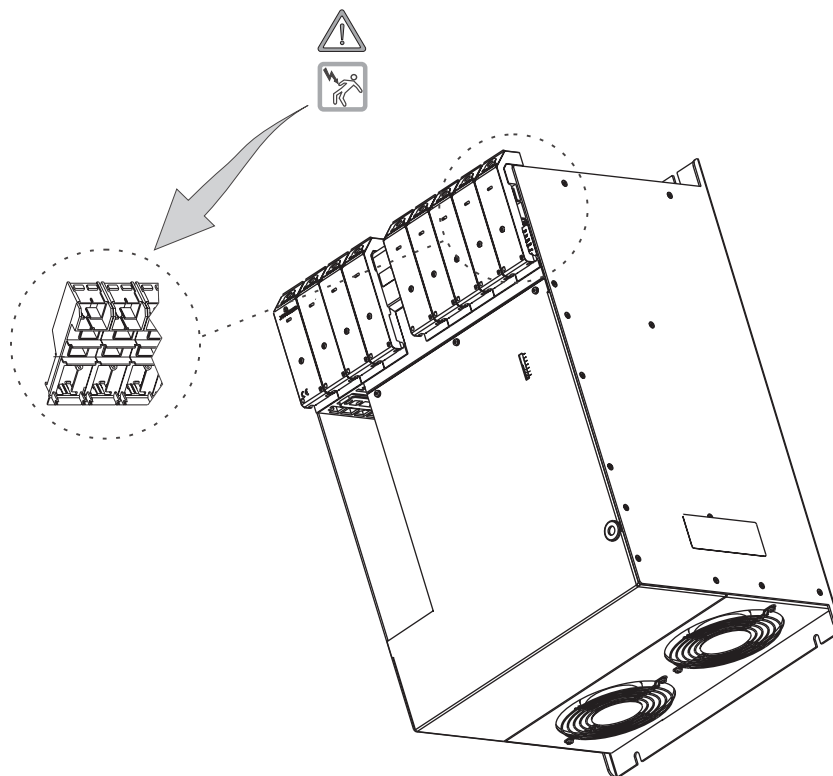

6.3 Requirements to the electrical mains

The units are intended for the permanent supply connection to the common TN and TT industrial supply network in star connection with hard or low impedance grounded neutral point according to IEC 364-4-41, chapter EN 413, chapter 413.1.3, chapter 413.1.4, they are for industrial networks with non- or high impedance grounded neutral point (IT supply) and for industrial networks with hard or low impedance grounded corner point (grounded delta wye) with a line-to-line voltage from up to $3 \times 480 \text{ V}_{\text{eff}}$.

in case you consider UL 508 C:

The maximum short-circuit current of the supply may be 10000 A.

A listing of the requirements to the electrical supply is to be found in ([►Requirements on the power supply◄](#) on page 108).

- Assure, that the existing supply fulfills all requirements.

6.4 Cable requirements

In the technical data ([▶Appendix D - Technical data◀](#) from page 107) you find data as e. g. environmental conditions, electrical connection data amongst other things, which must be regarded when selecting the cables. The unit BUM62 S/A/F complies with the requirements of UL508C, if the accordant cables are used and if the cable screwing is accordingly executed.



NOTE

In case of consideration to UL508C: Only 60°C / 75° C copper cables must be connected (UL508C Nov 27, 1996, table 39.2. Nominal tightening torque of terminal screws: 4 Nm or 35.4 pound-inches.

Additional data is available in appendix [▶Circuit mains - device◀](#) on page 114, [▶Cable control voltage supply/signals◀](#) on page 114 and [▶Cables device-motor◀](#) on page 114.

- Assure, that all cables, which are used accord to the requirements.

6.5 Connection

Here you find detailed information regarding all connections. An overview is to be found in [▶Connection diagram◀](#) on page 63.

6.5.1 Power connections



DANGER

The following **will occur**, if you disregard this safety information:

- ▶ considerable damage to property ▶ serious personal injury ▶ death
- ◆ Assure, that the permissible connection value (see [▶Electrical data◀](#) from page 111) never is exceeded!
- ◆ Again mount the covers, which have been provided and screw on the covers, after the cables have been connected to the power connections.
- ◆ Assure, that the total power of BUM 62 is not greater than the power of the motors which are supplied by the lined up power modules, which the power supply converter can provide to the BUM 62.



NOTE

The terminals for the chopper resistor are not protected against overload, short-circuit and ground faults. The connection of a low resistance results in a destruction of the device. The value for the chopper resistor is found in [▶D.3 Electrical data◀](#) from page 111.

6.5.2 Power connections BUM 62 S/A/F

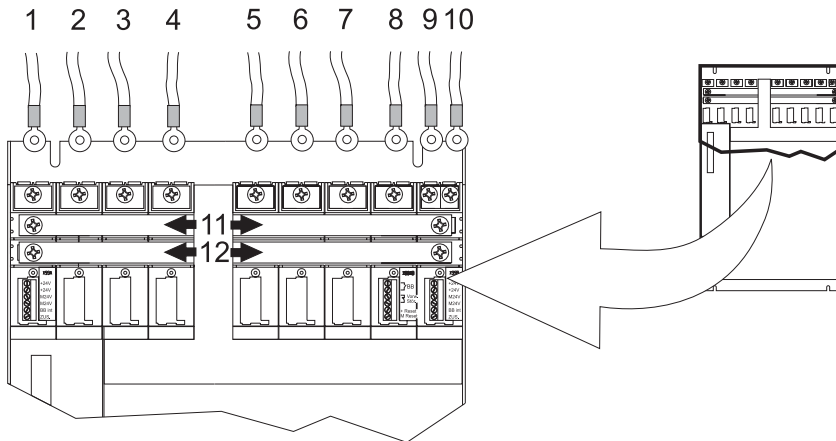

Figure 14: : Power connections BUM 62 S/A/F

Terminal	Pos. ¹⁾	Description	U _{Range} [*]	I _{Range} ^{**}	A ⁴⁾
U	1	Motor connection phase U	max. 570 V	max. 130 A	10 - 25 mm ² 8 - 4 AWG
V	2	Motor connection phase V			
W	3	Motor connection phase W			
⊖	4	Ground connection			
L1	5	Mains connection phase L1	400 V -15% to 460V +10%	max. 105A	
L2	6	Mains connection phase L2			
L3	7	Mains connection phase L3			
⊖	8	Ground connection	between Ba+ and Ba- max. 800 V _{DC}	max. 73 A	
Ba+ ⁵⁾	9	Connection chopper resistor Ba+ is internally connected with DC link+, Ba- is connected with the collector of the brake switch			
Ba- ⁵⁾	10				
DC link+	11	Connection DC link Connection of two Baumüller units	between DC link+ and DC link- max. 800 V _{DC}	max. 65 A	16 mm ²
DC link-	12				

1) Position see ▶Figure 14◀ on page 47

2) Voltage range (RMS voltage)

3) Current range (RMS current)

4) The connection cross-section is selected acc. to the valid standards dependent on application. The stated values specify, which flexible conductors are safely clamped.

5) optional

6.5 Connection

6.5.3 Power connections BUM 62-70/200

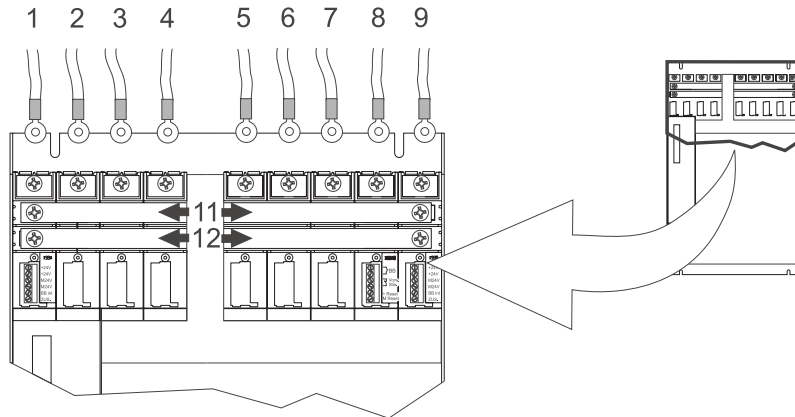

Figure 15: : Power connections BUM 62-70/200

Terminal	Pos. ¹⁾	Description	U _{Range} [*]	I _{Range} ^{**}	A ⁴⁾
U	1	Motor connection phase U	max. 570 V	max. 130 A	10 - 25 mm ² 8 - 4 AWG
V	2	Motor connection phase V			
W	3	Motor connection phase W			
⊕	4	Ground connection			
L1	5	Mains connection phase L1	400 V -15% to 460V +10%	max. 105 A	
L2	6	Mains connection phase L2			
L3	7	Mains connection phase L3			
⊕	8	Ground connection			
RK	9	Connection resistor for DC link quick discharge	between RK and DC link+ max. 800 V _{DC}		
DC link+	11	Connection DC link Connection of two Baumüller units	between DC link+ and DC link- max. 800 V _{DC}	max. 65 A	16 mm ²
DC link-	12				

1) Position see ▶Figure 14◀ on page 47

2) Voltage range (RMS voltage)

3) Current range (RMS current)

4) The connection cross-section is selected acc. to the valid standards dependent on application. The stated values specify, which flexible conductors are safely clamped.

5) optional

DC link terminals DC link+ and DC link- (line up units)

If a Baumüller unit is lined up to the BUM62 S/A/F, the DC links of both units must be connected.

In case power modules are lined up, the power supply converter of the BUM 62 provides the connected power modules. There is an exchange of energy (e. g. at braking) between the single modules.

The connection to further units, can be made by bars at the BUM62 S and at the BUM62-70/200, at the versions BUM62 A/F there must be a cable connection.

**NOTE**

A BUK 622-54-05 must be lined up to the BUM62 70/200.

**DANGER**

The following **will occur**, if you disregard this safety information:

- ▶ considerable damage to property ▶ serious personal injury ▶ death
- ◆ The total power of the BUM62 S/A/F motors, which are supplied via the lined up power modules may not exceed the power, which the BUM62 S/A/F power supply converter can provide BUM62 S/A/F.

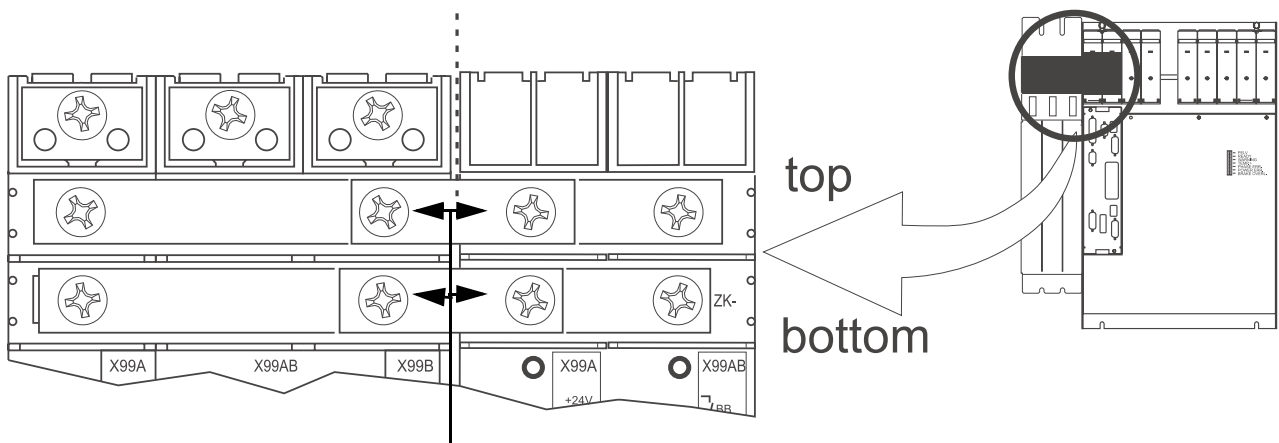

Screw terminals for conductor bars, M6

Figure 16: DC link connection

Terminal	Pos. ¹⁾	Description	U _{Range} [*]	I _{Range} ^{**}	A ⁴⁾
DC link+	top	Connection DC link Connection of two Baumüller units	between DC link+ and DC link- max. 800 V _{DC}	max. 65 A	16 mm ²
DC link-	bottom				

1. Position see ►Figure 16◄ on page 49
2. Voltage range (RMS voltage)
3. Current range (RMS current)
4. Connection cross-section of bars and cables



DANGER

The following **will occur**, if you disregard this safety information:

- considerable damage to property ► serious personal injury ► death
- ◉ Mount and screw on the provided covers again, after the DC links of both units have been connected with one another.

6.5.4 Control connections



WARNING

The following **can occur**, if you disregard this warning instruction:

- serious personal injury • death

*The danger is: **electricity**.*



Avoid to overload the control connections. The permissible maximum current of 10 A per terminal may not be exceeded.

Assure that all control voltages meet the PELV or SELV.

6.5.4.1 Control connection X99A + X99B

Use the plug-in terminals, which are attached in order to connect X99A and X99B. In case that further plug-in terminals are necessary, these can be obtained from Baumüller or directly from the manufacturer (see [▶Connector◀](#) on page 97).

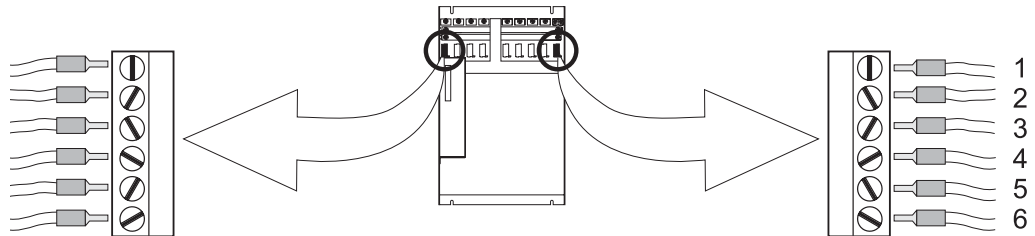
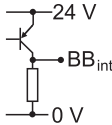

Figure 17: : Control connections X99A, X99B

Terminal	Pos. ¹⁾	Description	U _{Range} ²⁾	I _{Range} ³⁾	A ⁴⁾
+24 V	1	+ 24 V _{DC} (PELV) ⁵⁾ Terminals 1 and 2 internally bridged.	21.6 V (U _{DC}) to 28.8 V (U _{DC})	0 A (I _{eff}) to 10 A (I _{eff})	0.2 to 2.5 mm ² AWG 24 to 12
+24 V	2				
M 24 V	3	Ground 24 V _{DC} (PELV) Terminals 1 and 2 internally bridged.	0 V (U _{DC})		
M 24 V	4				
BB _{int.}	5	Message „ready-to-operate internal“ ⁶⁾ 0 V: supply unit not ready-to-operate 24 V: supply unit is ready-to-operate  Figure 18: : Ready-to-operate internal	0 V (U _{DC}) or 24 V (U _{DC}) (PLC level)	0 A (I _{eff}) to 0.2 A (I _{eff})	
ZUS.	6	Reserved If there is no chopper resistor, connect this contact with contact 1 or 2	-	-	

- 1) Position from the top
- 2) Voltages, which can occur at the terminals
- 3) Currents, which can flow via the terminals
- 4) Connection cross-section of conductor. Consider EMC notes at connection (see [▶Requirements on the laying \(EMC instructions\)◀](#) from page 57)
- 5) Connection control voltage +24 V for mains supply of the device



NOTE

The power supply has capacitors at the input (250µF), so that when switching the 24 V supply charging currents can occur.

⁶⁾ This message is only related to BUM 62! (also see [▶Ready-to-operate◀](#) from page 75)

X99A (line up units)

In case you line up a Baumüller unit to the BUM62 S/A/F you must connect the terminals 1 to 5 from relay X99B of the lined up unit with the terminals 1 to 5 of the relay X99A of BUM62 S/A/F.

Connection:

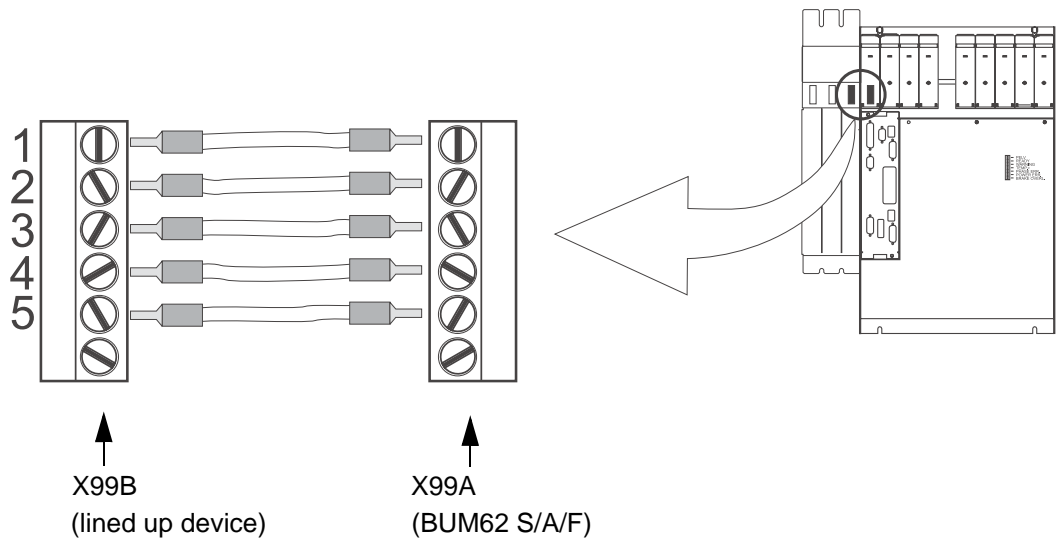

NOTE

The combination of two plug-in terminals and of connecting cables (see above mentioned figure) is available as accessories at Baumüller Nürnberg.

6.5.4.2 Control connection X99AB

Use the attached plug-in terminals, in order to connect X99AB. In case that further plug-in terminals are necessary, these can be obtained from Baumüller or directly from the manufacturer (see [►B.1 Connector◄](#) on page 97).



WARNING ()

The following **can occur**, if you disregard this warning instruction:

► considerable damage to property ► serious personal injury ► death

◆ Assure, that there is a multiple-separated supply, if there are higher current requirements.

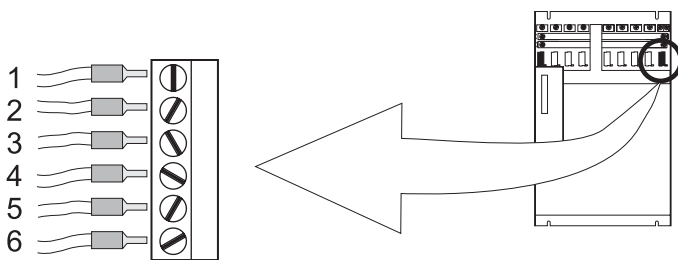
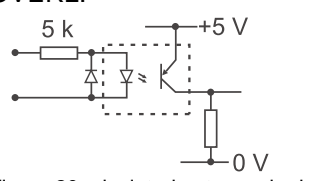

Figure 19: : Control connection X99AB

Terminal	Pos. ¹⁾	Description	U _{Range} ²⁾	I _{Range} ³⁾	A ⁴⁾
BB _(ext)	1	Message „ Ready-to-operate external “ ⁵⁾ Open contacts: Supply unit not ready-to-operate	0 V (U _{DC}) to 24 V (U _{DC})	0 A (I _{DC}) to 0.5 A (I _{DC})	max. 2.5 mm ²
	2	Closed contacts: Supply unit ready-to-operate			
Vorw. Stör.	3	Message „ pre-warning “ (PELV) Closed contacts: Supply unit - no warning			
	4	Open contacts: Supply unit - warning			
+Reset	5	isolated optocoupler input in order to Reset of error messages: PHASE ERR, POWER ERR, and BRAKE OVERL. 	0 V (U _{DC}) or 24 V (U _{DC}) (PLC level)	10 mA (I _{DC}) to 25 mA (I _{DC})	
M Reset	6	Specified point to input + reset	0 V	-	

- 1) Position see ▶Figure 19◀ on page 53
- 2) Voltages, which can occur at the terminals
- 3) Currents, which can flow via the terminals
- 4) Connection cross-section of conductor.

6.5.4.3 Safety relay X68 (optional)

With the safety relay the drive can be switched to a torque-free state.



WARNING

The following **can occur**, if you disregard this warning instruction:

- serious personal injury
- death



*The danger is: **mechanical influence** by failure of safety relay.*

Assure that the minimum current of the contacts 1 and 2 are not less than 10 mA during operation. Operate the safety relay within its specifications.

Coil side	
Rated voltage	24 V (PELV)
Operating voltage	19 V to 37 V at $T_U = 20\text{ °C}$ (PELV)
Coil resistance	660 Ω to 905 Ω

Contact side	
Switching voltage U_{AC}	max. 25 V_{AC} (PELV)
Switching voltage U_{DC}	max. 60 V (PELV)
Switching current	max. 5 A
Continuous current	min. 10 mA - max. 6 A
Switching capacity P_{AC}	max. 150 VA
Switching capacity P_{DC}	max. 30 W

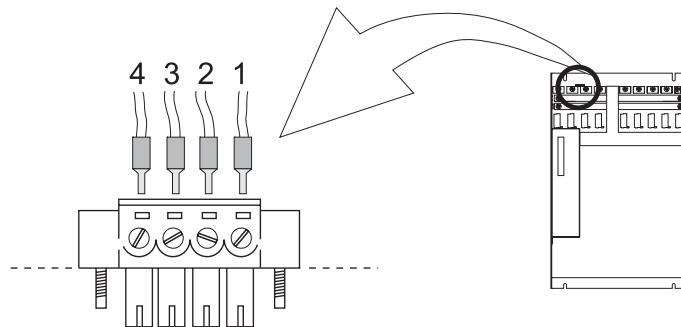



Figure 21: : Safety relay X68

Terminal	Pos. ¹⁾	Description	$U_{\text{Range}}^{2)}$	$I_{\text{Range}}^{3)}$	$A^{4)}$
	1 2	Status signal contact (NC), if safety relay is active (PELV)	0 V (U_{DC}) to 24 V (U_{DC})	0 A (I_{DC}) to 0.5 A (I_{DC})	1.5 mm ²
+24 V	3	+ 24 V connection to deactivate safety relay (PELV)	0 V (U_{DC}) to 24 V (U_{DC})	0 mA (I_{DC}) to 35 mA (I_{DC})	1.5 mm ²
M 24 V	4	Specified point to input +24 V (PELV)	0 V (U_{DC})		

1) Position see ►Figure 21◀ on page 55

2) Voltages, which can occur at the terminals

3) Currents, which can flow via the terminals

4) Connection cross-section of conductor.

**NOTE**

When operating the motor, terminal 3 must be connected to +24 V (U_{DC}) and 4 with 0 V (U_{DC}).

'Safety relay off' is saved as a message and must be reset by the use of the controller.

A detailed description of the safety relay is to be found in ►Appendix E - Safety relay◀ from page 115.

6.5.4.4 DC link quick discharge X90



NOTE

Only BUM 62-70/100

It is discharged at +24 V on X90:1 via an external 1 Ω resistor between the connections DC link+ (bar) and RK of DC link in < 1 s. The user is responsible for the interlocking with main contactor ON

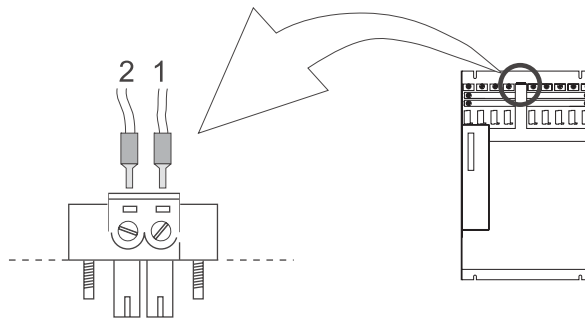

Figure 22: : DC link quick discharge X90

Terminal	Pos. ¹⁾	Description	U _{Range} ²⁾	I _{Range} ³⁾	A ⁴⁾
+24 V	1	+ 24 volt connection in order to activate the DC link quick discharge	0 V (U _{DC}) to 24 V (U _{DC})	0 mA (I _{DC}) to 35 mA (I _{DC})	1.5 mm ²
M 24 V	2	Specified point to input +24 V (PELV)	0 V (U _{DC})		

1) Position see [►Figure 21◀](#) on page 55

2) Voltages, which can occur at the terminals

3) Currents, which can flow via the terminals

4) Connection cross-section of conductor.

6.6 Fuses of the device

To protect the device or the cable connections at an ground fault, fuses must be installed accordingly. Use the fuse, which are listed in [►D.4 Fuse protection◄](#) on page 113!

6.7 Requirements on the laying (EMC instructions)

In these units semiconductors are used, which minimize the power loss in the unit by quick switching and therewith make a small size possible. This semiconductor generates electromagnetic waves by the quick switching. In order to avoid electromagnetic influences by switching procedures, certain preconditions must be observed at operation.

Interferences can arise throughout all areas of the drive system and originate in the following:

- capacitive discharge currents. Causes are the high voltage gradients at the switching of semiconductors.
- High currents and current gradients in the motor cables. The bonded interference energy in the magnetic field reaches frequencies of a few hertz up to about 30 MHz. Due to the high voltage gradients additionally electromagnetic fields with frequencies up to 600 MHz occur.
- high cycle rates and quick logic circuits (electromagnetic field/16 MHz to 1GHz).
- Reaction on system and harmonics. The cause are commutation procedures and not sinusoidal mains loadings especially at line-commutated converters .(100 Hz to 20 kHz).

NOTE



In this Manual the most important information for an EMC-compatible installation is available. Further notes, which must be considered in order to mount a CE-conform installation are to be found in the manual 'filters for mains applications'.

6.7.1 EMC regulation (EMVG)

This device accords to the § 6 para. 9 of the EMVG dated September 18, 1998:

'Devices, systems and parts in terms of paragraph 3, which exclusively are manufactured and are determined as subcontracting parts or spare parts for the subsequent processing by competent companies or persons in the field of electromagnetic compatibility, must not fulfill the protection requirements as well as the requirements of § 4 para. 1 no. 1 to 3 and 5.'

The assembly of the single modules and components in the control cabinet is decisive for the EMC. The notes on the following pages make it possible to configure the installation due to the latest EMC knowledge and therewith to follow legal regulations.

6.7.2 Measures for EMC-assurance

In order to assure the EMC the following configuration notes must be regarded.

6.7.2.1 Cabling

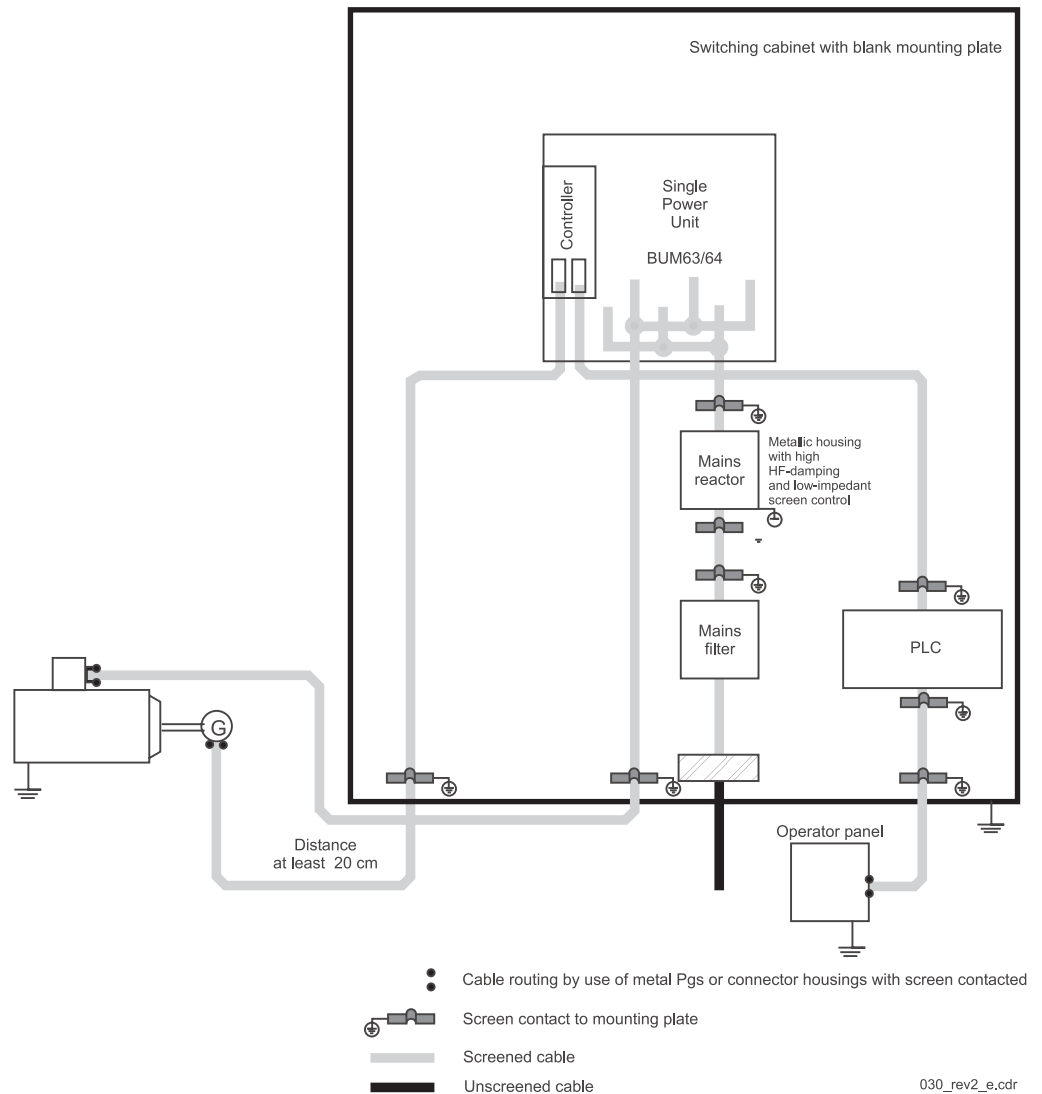

Figure 23: Cabling proposal BUM62 S/A/F

- ▶ Shield **all** connected cables, in order to keep the cables free from interfering radiation (see ▶ [Screening](#) ◀ from page 61). You can install unscreened control cables, if the control cabinet has a sufficiently high screen attenuation (see limit values for noise emission according to EMVG for your installation) and also if the EMC compatibility inside the control cabinet is guaranteed (this can be assumed if you have observed all configuration instructions given in this manual).
- It can be assumed, that the permissible limit values are observed, if motor cables are used, which where enabled.
- The maximum length of motor cable is limited. The length of the motor cable is dependent on the cross section of cable.

- The screened motor cable between converter and motor must be made of one piece. Do not interrupt the cable e.g. by terminals, contactors, fuses and so on.
- You achieve the lowest possible effective aerial height by routing the cable directly alongside the ground of a metallic surface.

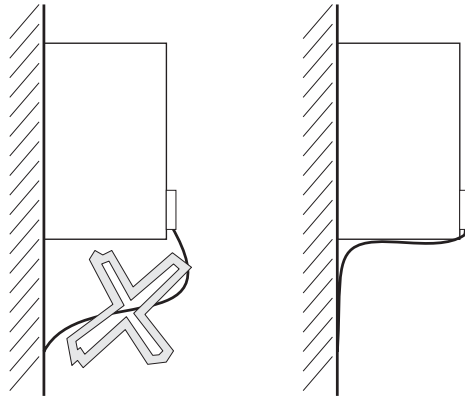

Figure 24: Reducing effective aerial height

- All cables should basically be laid as near as possible to the conductors of the ground system, in order to reduce the loop area which is effective for magnetic coupling.

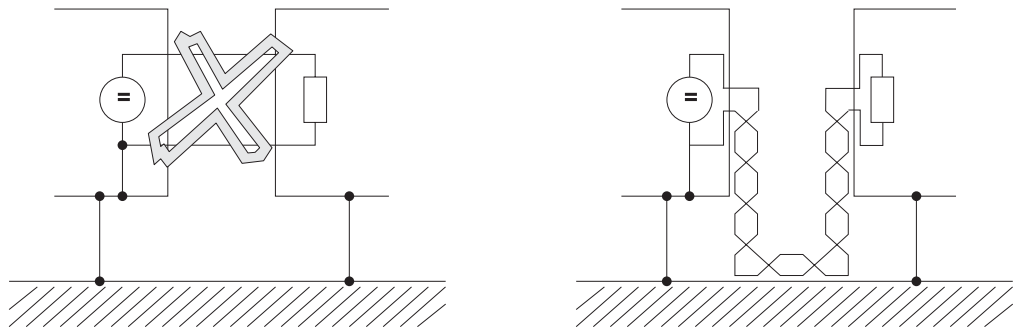

Figure 25: Reducing loop areas

- Keep a minimum clearance of 20 cm between the lines, when parallel-routing signal/control lines across power cables.
- Cross cables of different EMC categories only in a 90 °angle.
- For symmetrical signal transmission form twisted pair cables and twist those against all other twisted pairs (e. g. for differential amplifier inputs used for speed setpoint).
- Establish a connection between ground connection-converter/ground plane (< 30 cm). Use great cross-sections (>10 mm²).
- Connect the bus connection on the load side of the filter with low-impedance to the mounting board. Ideal is a zinc-plated sheet metal angle or a HF-grounding band.
- Keep a distance of at least 20 cm between converter and its cabling and
 - disturbance sources as contactors, transformers, chokes and
 - noise-sensitive components as μ Ps, bus systems a. s. o.
- Avoid reserve loops at extra-long cables.
- The grounding of reserve cables is mandatory on both ends (additional screening is achieved, you avoid capacitive coupled dangerous contact voltages).

6.7 Requirements on the laying (EMC instructions)

- ▶ Don't switch mains filters parallel.
- ▶ Don't connect mains filters of the same type of construction in series - the attenuation characteristics are not improved.
- ▶ Use a separate mains filter for each device. If you must suppress all drives together - do not interrupt the screening between the converter and the mains filter, except by the mains choke, which has to be mounted into a grounded metal housing, which is of low impedance.

6.7.2.2 Grounding

From the view of EMC the classical star-connected grounding is inadequate, in order to minimize the influence of interferences with higher frequencies. Better results are achieved by a reference surface which must be linked to the device's ground (e. g. plane metal mounting plate and housing parts).

- ▶ To avoid ground loops, position all ground conductors and screens as close as possible to ground.
- ▶ Execute the connection of controller reference potential - ground with a cross section, which is as great as possible and with a short cable (< 30 cm), as long as there is the possibility to ground the controller reference potential of the device.
- ▶ Remove insulation layers such as paint, adhesives a. s. o. from the ground connections.
- ▶ If necessary use lock washers (DIN 6798) or similar measures to ensure a permanent, conductive contact.
- ▶ Select suitable metal combinations (electro-chemical voltage series), in order to avoid corrosion on ground connections.
- ▶ Isolate conductive electrolytes with a protective coating (e.g. grease) from the connection.
- ▶ Connect screens on both ends plane and highly conductive with ground. Only like this magnetic or high-frequency interference fields are able to be attenuated in its actions.
- ▶ If there are problems with ground loops (e. g. double grounding of setpoint conductor), apply the receiver side galvanically and the sender side capacitively.
- ▶ Contact the outer cable screens with the housing, if the cable is passed through the housings, which separate different EMC areas from each other.

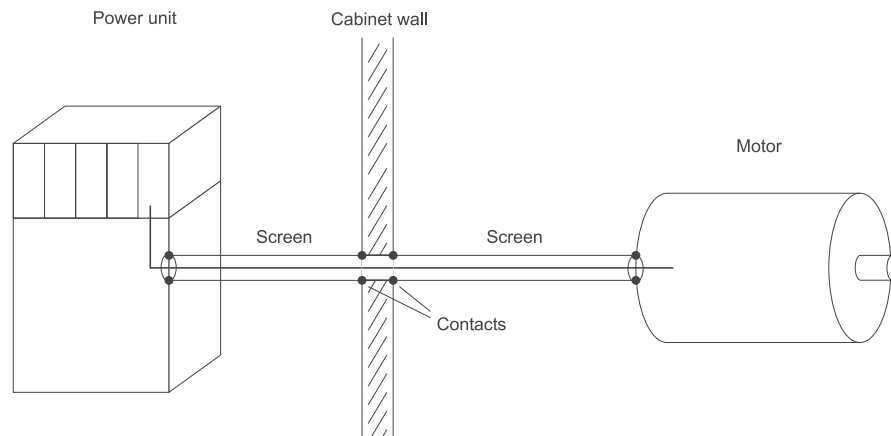

Figure 26: Contact cables when exiting the housing

Cables which exit the walls of screen housings without special precautions (e. g. filtering), may impair the screening effects of these housings.

- ▶ Therewith connect the cable screens also at the exiting point with a well conductive screening.
- ▶ Assure that the distance of the last screen contact point to the housing exit is as short as possible.

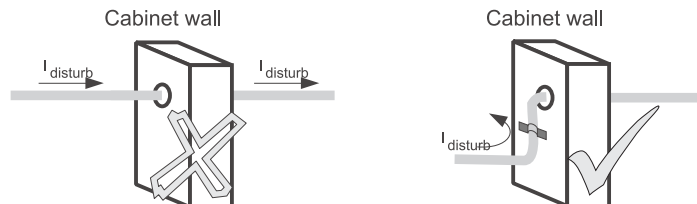

Figure 27: Cable screening at exiting housing

6.7.2.3 Screening

Screening is effective against magnetic fields if the screen is connected to ground on both ends.

With electrical fields a screening effect is already existent, if the screen is connected to ground on one side.

- ▶ Always apply the screen on both sides to the fields with high frequencies (dependent on the cable length), regardless of being an electric or a magnetic field.

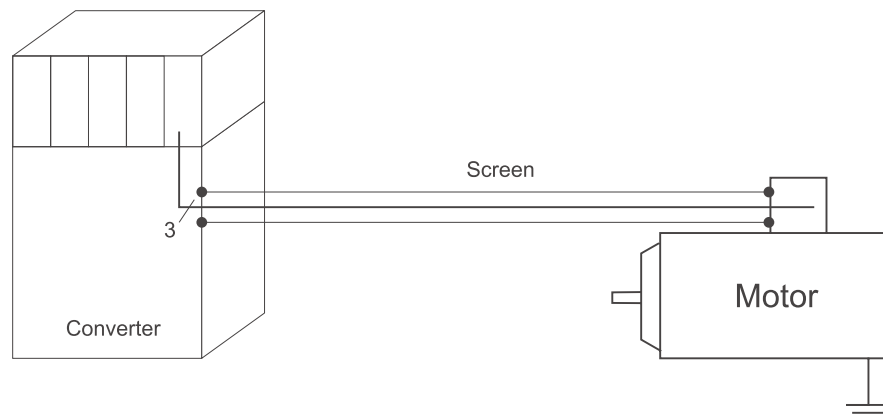

Figure 28: Screen on both sides

With both-sided applying of the screen on ground you reach that the cable doesn't leave the screening system housing.

The both-sided grounding of cable screenings nearly excludes an influence due to ground loops (potential differences on the ground system). These are very rare, if the notes from the sections ([▶Cabling◀](#) from page 58) and ([▶Grounding◀](#) from page 60) are regarded.

The HF-connection of a screen with ground can also occur capacitive. This avoids low-frequent errors due to ground loops.

- ▶ Screened cables that are routed through different EMC areas must not be interrupted at terminals, since screen attenuation would otherwise be reduced considerably.
- ▶ Run the cables without interruption to the next component, if this is possible.

6.7 Requirements on the laying (EMC instructions)

- ▶ Execute all screen connections by using a wide surface and with a low impedance.
- ▶ Screening connection may not be more than 10 cm from the edge of the device.

Cable tails with a length of only 3 cm (1cm wire = 10 nH) reduce the screening effect with errors in the MHz range up to 30dB!



NOTE

The braided screen must have a coverage of at least 85%.

The following cables possess an especially high noise potential:

- Motor cable
- Cable to external chopper resistors
- Cable between mains filter and converter

6.7.2.4 Filtering

The functioning of the device requires not filters. But to comply with the limit values of EN 61800-3 input-sided mains filters are necessary.

If you have questions on how to perform filtering you can order manual 'Filters for mains application BFN'.

6.7.2.5 Filter mounting

- ▶ Arrange the mains filter close to the unit.
- ▶ Use a screened mains cable between unit and filter at a cable length greater than 30 cm (grounding on both sides).
- ▶ Separate in- and output cables of the filter (distance > 30cm).
- ▶ Connect the filter housing plane with ground.

6.7.2.6 Leakage currents

Parasitic capacities in filter, power unit, motor cable and motor winding on principle cause leakage currents in the range of 100mA and greater.

Hence the converters can be incompatible with ELCBs!

- ▶ Pertinent to this refer to the safety instructions in the EN 50178/VDE 0160 para. 5.2.11.2.

6.8 Connection diagram

- Install the mains cables EMC compatible and then connect the cables as specified in the connection plan.



WARNING

The following **can occur**, if you disregard this warning instruction:

- serious personal injury • death

*The danger is: **electricity**.*

Assure, that the permissible connection value (see [►Electrical data◄](#) from page 111) never is exceeded!

Again mount the covers, which have been provided and screw on the covers, after the cables have been connected to the power connections.

Make sure that the total power of the supplied motors BUM62 S/A/F via the lined up power modules is not greater than the power, which the supply converter of the BUM62 S/A/F can provide.



NOTE

- Please refer to the connection diagram for the device BUM 62-70/200 on [►Page 65◄](#).

6.8 Connection diagram

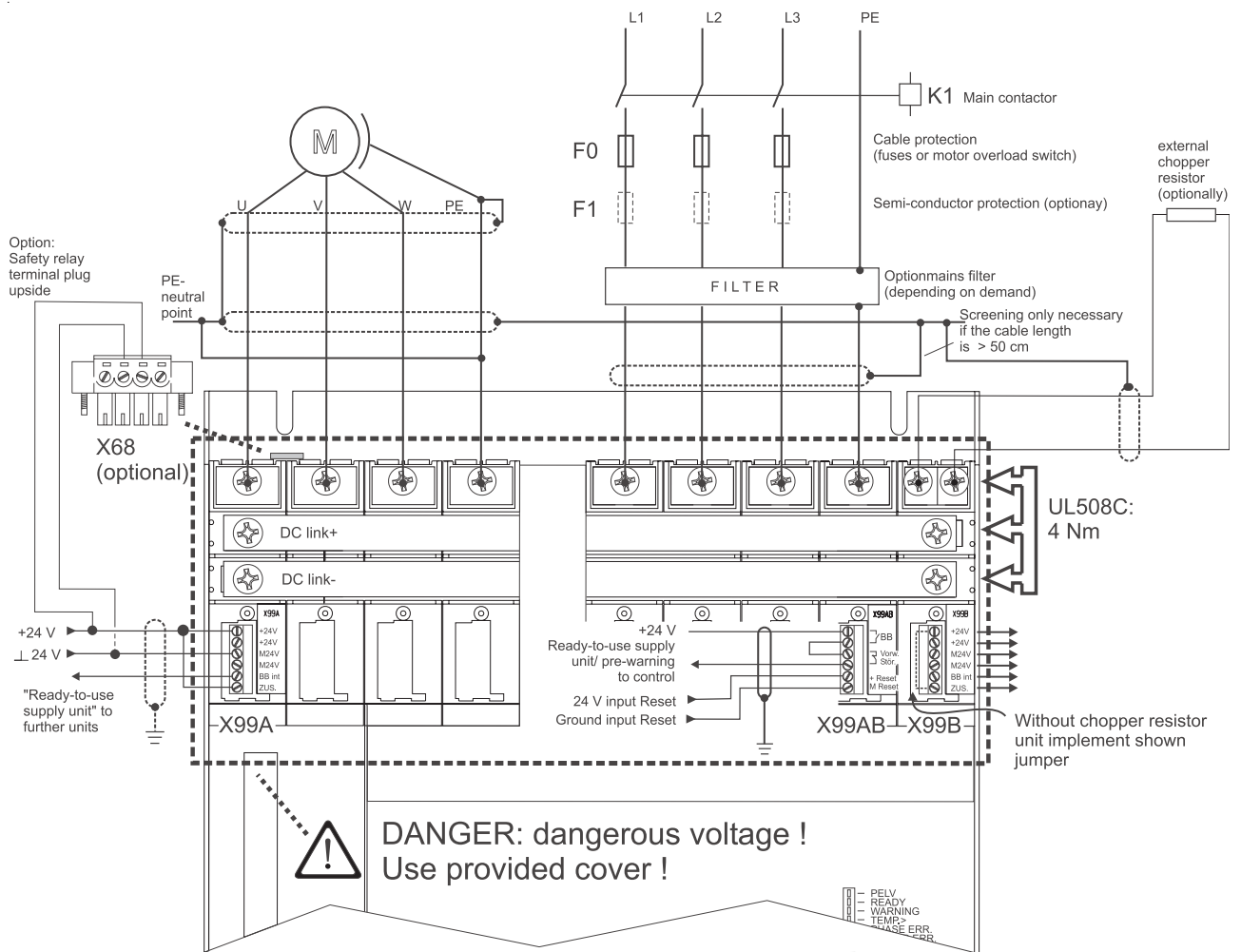

Figure 29: Connection diagram BUM62 S/A/F

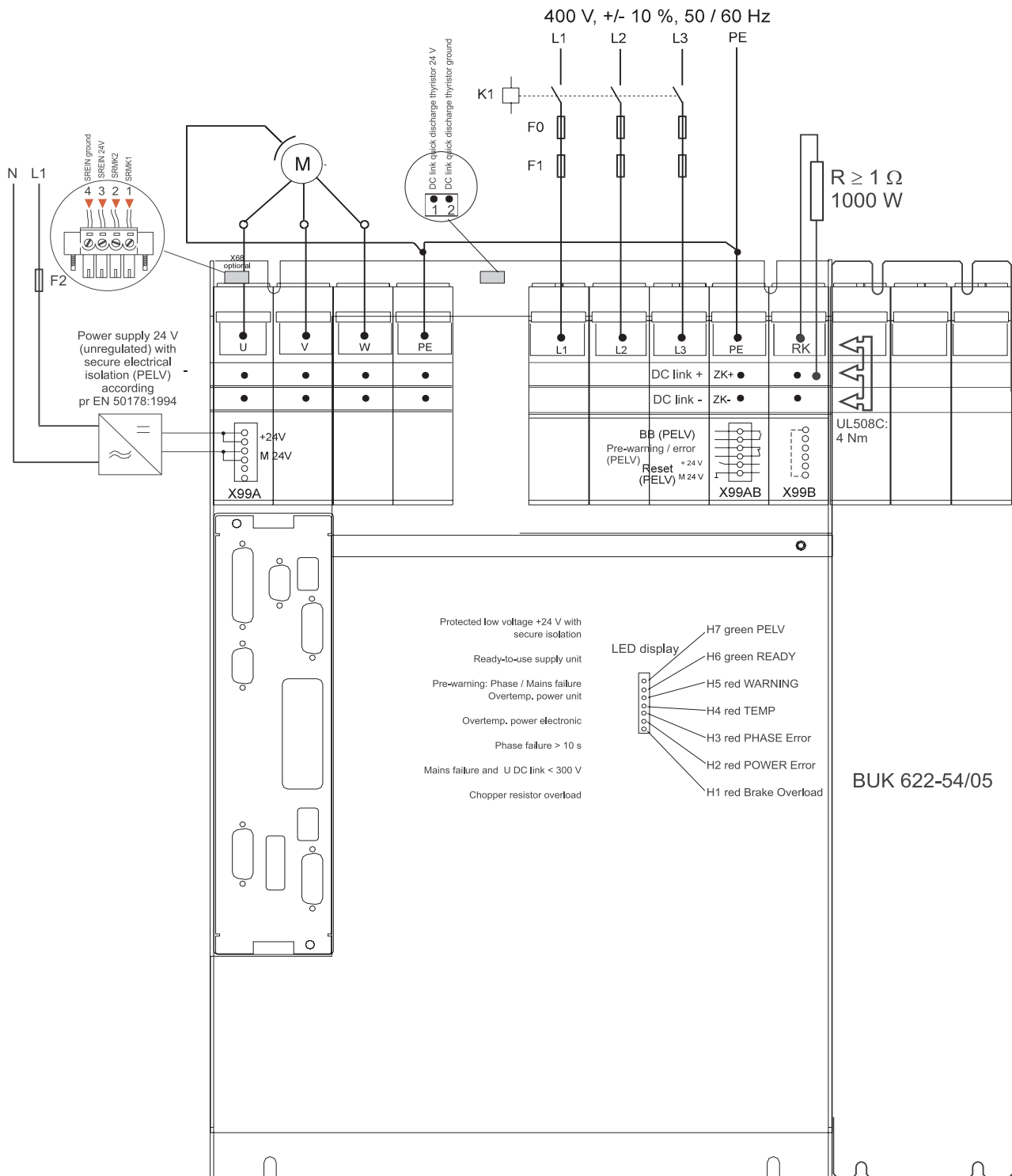



Figure 30: Connection diagram BUM 62-70/200

6.8 Connection diagram

Information concerning the individual connections are to be found from section [►Power connections◄](#) from page 46.

Further connection notes are to be found in the following table.

F0	Cable protection fuse, use fuse dependent to supply cables (DIN VDE0100-430)
F1	Fuse for protection of semiconductors or full-range protection (see ►D.4 Fuse protection◄ on page 113)
F2	Fuse dependent of used mains unit
ELCB	Principally in the converter and in the motor there is a relative high leakage current to ground, that means that the drive can be incompatible to the ELCB devices. For configuration the pr EN 50178: 1994 para. 5.2.11.2 must be regarded. Only type B is permitted, if an ELCB is used on the mains side of this electronic equipment (EB) in order to protect against direct or indirect touching. Otherwise other safety precautions must be made as e. g. environmental separation with a double or strengthened insulation or by the separation of the power supply with an isolated transformer.
K1	Line contactor (auxiliary contact for controller enable optional, not mandatory)
L1, L2, L3, PE	Cross section supply connection according to EN 60204-1:1992 Laying of the cables see EMC instructions. In case of consideration to UL508C: Nominal tightening moment of terminal screws: 4 Nm or 35.4 pound-inches.
U, V, W, 	Motor connections cross section according to EN 60204-1:1992. Laying of the cables see EMC instructions. Screening is only if the spatial separation of signal cables is not possible or if interferences in the communication equipment must be expected. In this case the shield of the motor supply lead must be rated with low impedance on both sides. In case of consideration to UL508C: Nominal tightening moment of terminal screws: 4 Nm or 35.4 pound-inches.
DC link+, DC link-	DC link connection of further axes, if the total power of the input converter is not exceeded Also a DC link connection of further units as chopper resistor. In case of consideration to UL508C: Nominal tightening moment of terminal screws: 4 Nm or 35.4 pound-inches.
+ 24 V ⊥ 24V	24 V power supply with safe isolation (PELV) acc. to IEC 61131-2; table 7 in order to supply the electronic part
Ba+, Ba-	Connection for chopper resistor. In case of consideration to UL508C: Nominal tightening moment of terminal screws: 4 Nm or 35.4 pound-inches.

RK	Connection resistor for DC link quick discharge. Connect-up resistor $R \geq 1 \Omega / 1000 \text{ W}$ between DC link+ and RK. In case of consideration to UL508C: Nominal tightening moment of terminal screws: 4 Nm or 35.4 pound-inches.
----	---

**WARNING**

The following **can occur**, if you disregard this warning instruction:

► considerable damage to property ► serious personal injury ► death

The DC link is subject to mains potential! Use the enclosed cover.

6.9 Screwing in accordance with UL

Use a suitable torque code, in case an UL-relevant screwing acc. to UL508C is necessary.

COMMISSIONING

Commissioning consists of the following steps:

- 1 Check mounting
- 2 Check installation
- 3 Check safety devices
- 4 Check operating- and display elements

Additional data concerning the single steps is available in the following sections.

7.1 Requirements to the executing personnel



WARNING

The following **can occur**, if you disregard this warning instruction:

- serious personal injury • death



*The danger is: **electricity**. When operating with this electrical unit, inevitably certain parts of this unit are under dangerous voltage.*

Make sure, that only qualified personnel, who are familiar with the safety- as well as with mounting-, operating- and maintenance instructions, work on this unit.

Qualified personnel are persons, who have been instructed by the responsible person, based on their training, experience, the instructions they were given as well as their knowledge about relevant standards and instructions, knowledge of the accident prevention instructions and of the company, to execute the necessary operations and thereby are able to recognize and avoid the dangers which could happen. The required qualifications for the work with this unit are for example:

- Education or instruction or to have the authorization to put into operation, ground and label circuits and devices according to the standards of safety engineering.
- Training or instruction due to the standards of the safety engineering in maintenance and use of appropriate safety equipment.

7.2 Checking the mounting

- ▶ Assure, the unit is properly screwed to the control cabinet.
- ▶ Assure, that sealing has not been damaged (is only valid for through-hole versions)
- ▶ Assure, that the cooling circulation is dense (only valid for versions I/F).

7.3 Checking the installation



WARNING

The following **can occur**, if you disregard this warning instruction:

- serious personal injury • death

*The danger is: **electricity**. Voltage conducting parts must be protected against direct touch.*

This you can achieve by insulation, model, positioning or stationary devices.

The power connections of power unit are non-isolated!

Essential for personal protection are the safety precautions and safety instructions acc. to DIN/VDE. If protective conductor connections are missing at the device or at the motor it must be reckoned on personal injury, because the surfaces may carry dangerous voltages.

The protective conductor connection must be made according to DIN EN 60204/VDE 0113 part 1; paragraph 8.2.2 with consideration to EN 50178/VDE 0160, paragraphs 5.3.2.1 and 8.3.4.4.

During operation in the power unit and in the motor there are discharge currents to ground, which are discharged via the specified protective connection and can result in a release of a connected ELCB.

In case of a fault to frame or a ground fault a direct component in the ground leakage can occur, which complicates or avoids the enable of a higher-level ELCB.

Even if the main contactor is falling the parts of the power unit are under dangerous voltages.

- ▶ Check, if the cables to the power connections have been correctly installed and connected.
- ▶ Check, if the cables to the signal connection have been installed and connected properly.

7.4 Checking the safety devices



WARNING

The following **can occur**, if you disregard this warning instruction:

- serious personal injury • death

This unit is under dangerous voltage and contains dangerous rotating machine parts (fan).

Control cabinets must have emergency stops, where all voltages, which can cause hazards, can be switched off. This does not include equipment, where a new danger occurs, when it is switched off. The release of the emergency stop must be attached, so that, if there is danger, it can be reached quickly. In case there are obviously dangerous operations to be executed, then the presence of a further person is necessary.

- ▶ Before activating the drive check thoroughly the function of all higher-levelled safety devices, in order to avoid personal danger.
- ▶ Before commissioning assure that the plastic covers are over the parts under voltage (power unit connections) and that the fans are covered with an accordant lattice.
- ▶ Assure, that the touch protection has been carried out according to BGV A2.

7.5 Procedure of commissioning



WARNING

The following **can occur**, if you disregard this warning instruction:

- serious personal injury • death

During the initial operation an incorrect or uncontrolled movement of the powered machine elements can occur. Therefore exercise reasonable care when commissioning the first time.

Special caution is necessary at direct or indirect contact of drive shaft (of hand). This is only permitted at standstill of shaft and off-circuit power unit or deactivated safety relay. If there are uncovered machine parts, these must be covered at operation (shafts, fans, or similar).

If there is an error then the drive is changed to zero-current, after that the motor coasts down non-braked. This must especially be considered at travel- and lift drives.

- ▶ Assure, that no persons are in the danger range of the operating machine.
- ▶ Assure, that the installation immediately is able to be switched off via the emergency stop.
- ▶ Switch on the unit and pay attention to faulty or uncontrolled states of installation.

8

OPERATION

The device is operated exclusively via the controller (see controller description). The only exception is the reset (acknowledge) of errors via the optocoupler input „reset“ of the plug-in terminal X99AB.

In this chapter we do not describe the operation but the monitoring and display elements on the device, which are important for the operation.

8.1 Safety instructions



WARNING

The following **can occur**, if you disregard this warning instruction:

- serious personal injury
- death

Immediately report changes, which could affect the security.

In order to commission or repair, set the machine/installation in exact accordance with the instructions out of operation before demounting the safety devices.

Mount the safety devices again and assure their function directly after completion of commissioning or repairing it.

8.2 Monitoring functions and its messages



NOTE

The monitoring functions are only active, if the +24V-supply voltage (X99A) is present.

The monitoring functions of the unit are divided into two groups. The first group is 'Monitoring functions supply unit' see [▶Figure 4◀](#) on page 27. The second group is 'Monitoring functions motor-sided power unit'. This division corresponds to the internal construction of the unit.

8.2 Monitoring functions and its messages

8.2.1 Monitoring functions supply unit

The messages, which were generated from the 'monitoring functions supply unit' are indicated via relay contacts and/or are displayed via light emitting diodes (LEDs). The messages simultaneously are transferred and then processed by the controller.

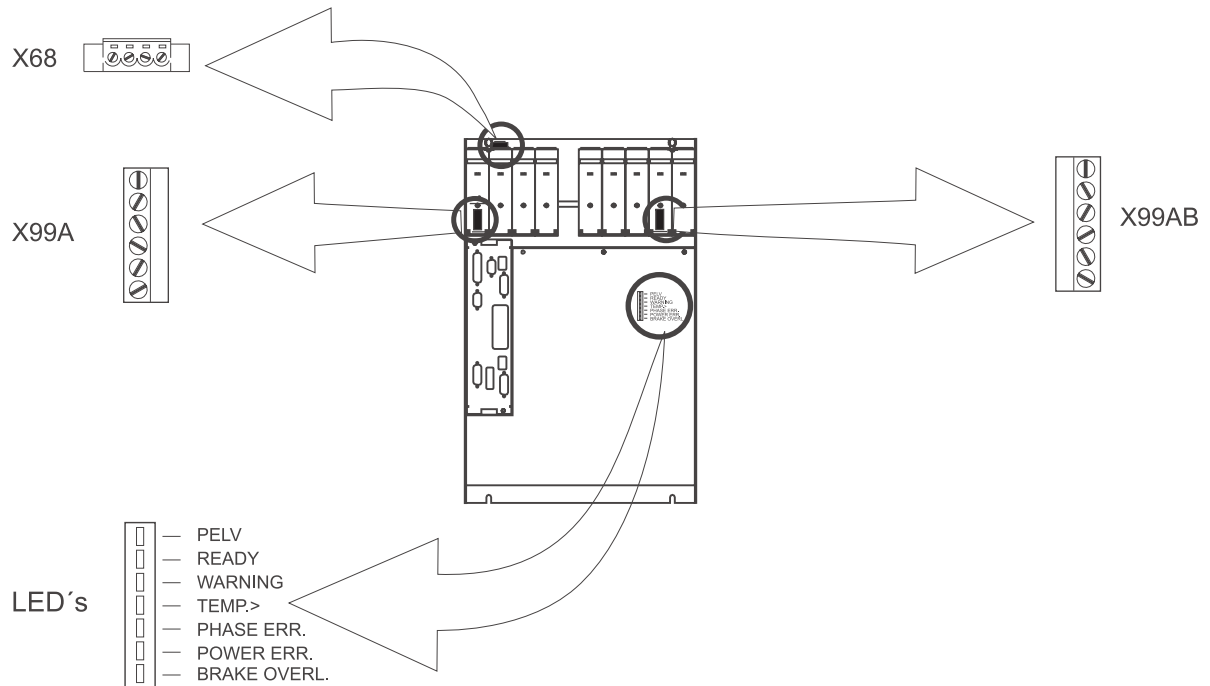

Figure 31: Position of relay contacts and of LEDs

8.2.2 Monitoring functions motor-sided power unit

The messages, which were generated by 'monitoring functions motor-sided power unit' are exclusively forwarded and processed to the controller. Additional data is available in [Monitoring functions](#) on page 77.

8.3 Ready-to-operate

The message 'ready-to-operate' is the most important message to know. If a monitoring function generates a message, which resets the message 'ready-to-operate' in the last resort the production of the installation is stopped.

There is not only one single message 'ready-to-operate'. If, for example, a V-controller is in the unit, there are four different messages 'ready-to-operate' in one drive.

- 'Ready-to-operate supply unit' (in the unit existent and visible)
 - = 'Ready-to-operate internal' (digital output)
 - = 'Ready-to-operate external' (relay contacts)
- 'Ready-to-operate power unit' (in the unit existent and **not** visible)
- 'Ready-to-operate controller' (existent in the controller)
- 'Ready-to-operate total' (in the controller)

The message 'ready-to-operate total' is dependent on the three other ready-to-operate messages. When the messages 'ready-to-operate supply unit' and 'ready-to-operate power unit' and 'ready-to-operate controller' are available, the message 'ready-to-operate total' is displayed (see figure ► 'Ready-to-operate (BB)' ◀ on page 75).

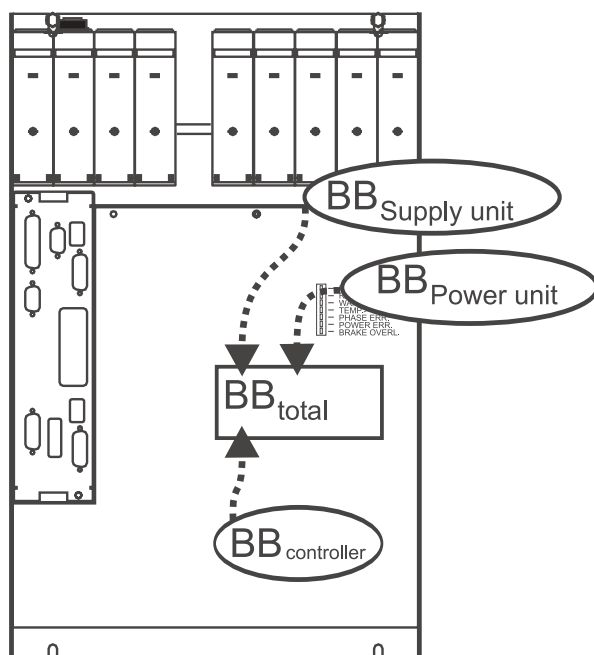

Figure 32: 'Ready-to-operate (BB)



NOTE

After applying the +24V control voltage and the mains voltage, the unit is ready-to-operate in approximately five seconds.

„Ready-to-operate power unit“ after approx. 0.5 s, „Ready-to-operate controller“ after approx. 4.5 s

In the following section additional data is available according to the different 'ready-to-operate' messages.

- 'Ready-to-operate supply unit'** If the 'monitoring function supply unit' does not detect errors, the monitoring function generates the message 'ready-to-operate supply unit'.
- If the message 'ready-to-operate supply unit' is reset by the monitoring function, the drive is switched to a torque-free status, i. e. the unit does not supply power anymore.
- The unit displays this message by a LED and at the same time applies the message to the relay contacts. Additional data is available in [►Messages via LEDs◄](#) on page 82 and [►Messages via relay contacts◄](#) on page 83.
- The „ready-to-operate supply unit“ is also designated „ready-to-operate internal“ (terminal marking BB INT) or „ready-to-operate external“ (terminal marking BB ext).
- It is always the same message at both messages. The differentiation is due to the internal structure of the unit.
- At the output of the supply unit the 'Ready-to-operate supply unit' is also designated 'Ready-to-operate internal'. After the message within the unit has been transferred to the power unit, the message 'Ready-to-operate supply unit' is designated 'Ready-to-operate external'.
- 'Ready-to-operate motor-sided power unit'** If the 'monitoring function motor-sided power unit' doesn't locate an serious error, the monitoring function generates the message 'ready-to-operate motor-sided power unit'.
- If the message 'ready-to-operate supply unit' of monitoring function is reset, the device changes the drive to torque-free, e. g. the unit doesn't supply power anymore.
- 'Ready-to-operate controller'** Here also the above mentioned is valid. In the documentation for the controller, which is used, you will find information, if the message 'Ready-to-operate controller' is existent and if so, how to process the message 'Ready-to-operate controller'.
- 'Ready-to-operate total'** In the documentation for the controller, which is used, you will find information, if the message 'Ready-to-operate total' is there and if so, how to process the message 'Ready-to-operate total'.

8.4 Monitoring functions

The following table is listing all of the monitoring functions. A declaration of every single monitoring function is to be found on the following pages.

Monitoring function		LED	Relay	V-Controller	Reset
Supply unit	Phase failure	WARNING PHASE ERR.	- X99AB; 3.4 X99AB; 1.2	- F 0110 ¹⁾	- 24 V ²⁾
	Mains failure	WARNING POWER ERR.	- X99AB; 3.4 X99AB; 1.2	- F 0110 ¹⁾	- 24 V ²⁾
	Short-circuit chopper resistor output	BRAKE OVERL.	X99AB; 1.2	F 0110 ¹⁾	³⁾
Motor-sided power unit	Overcurrent (motor)	-	-	F 0202	Reg. ⁴⁾
	Ground current (short-circuit)	-	-	F 0203	Reg. ⁴⁾
	Overcurrent DC link	-	-	F 0201	Reg. ⁴⁾
	Power transistors	-	-	F 0207	Reg. ⁴⁾
	Overtemperature heatsink	-	-	F 0205	Reg. ⁴⁾
	Internal auxiliary supply	-	-	F 0204	Reg. ⁴⁾
	Safety relay	-	X 68; 1.2 ⁵⁾	F 0206	Reg. ⁴⁾ ⁵⁾

¹⁾ The V-controller always displays this group error signal if an error appears in the supply unit. Which kind of error has occurred, is shown on the according LED on the front side of the supply unit.

²⁾ Activate reset-input (apply +24V and M24V at X99AB, optocoupler input).

or

switch off +24V supply voltage.

Thus **all** messages of the supply unit are reset!

Considering the message WARNING, you have the possibility to bring the drive into a defined operational status, before the power unit resets the message 'ready-to-operate supply unit' and turns to a current-free state.

³⁾ Not possible via reset input! Due to safety reasons you must wait, until the DC link is discharged ($U_{DC \text{ link}} < 20 \text{ V}$), then switch off the +24 V supply voltage.

Thus **all** messages of the supply unit are reset!

⁴⁾ The message must be deleted by a reset of the controller.

Display and deleting of the message is described in the manual of the controller.

⁵⁾ A message only then appears, if the safety relay is switched off. The safety relay is switched off then, if the +24V-supply voltage for the relay is inexistent.

Before you are able to delete the message by a reset of the controller, you must switch on the +24V supply voltage again.



NOTE

Reset: In case the message is not reset, it is in all probability, that the cause of the error still is existent.

8.4.1 Monitoring functions of the supply unit

There are 3 monitoring functions of the supply unit.

A preliminary information according these monitoring functions are in [►Monitoring functions supply unit◄](#) on page 74. In the following is a detailed description of the monitoring functions of the supply unit.

- **Monitoring function phase failure**

The voltage of all mains phases is monitored. If voltage is missing at a mains phase, the unit generates the message WARNING. If voltage recovers within ten seconds, the message WARNING is reset. If the voltage of the mains phase is missing more than 10 seconds, the message WARNING is reset and the message „Phase failure“ is saved. The message 'ready-to-operate supply unit' is reset.



NOTE

If the BUM62 S/A/F is operated with high motor power during phase failure, the input rectifier may be destroyed. In order to avoid this semiconductor fuses must be used.

- **Monitoring function mains failure**

The voltage of all mains phases is monitored. There are two different situations:

- the voltage is missing at two or three mains phases and
the **DC link voltage is slowly dropping**.
 - the message WARNING is set.
 - the message „mains failure“ is set, as soon as the DC link voltage is less than 300 V.
 - the message „ready-to-operate supply unit“ and the message WARNING are reset.
- the voltage is missing at two or three mains phases and
the **DC link voltage drops very quickly (within a few milliseconds)**.
 - the message „mains failure“ is set, as soon as the DC link voltage is less than 300 V.
 - The message 'ready-to-operate supply unit' is reset.
 - the message WARNING is (for a few milliseconds) set.

Reason: if the voltage is missing at two or three mains phases, the operation „output of message WARNING“ is started. This operation lasts a few milliseconds. If the DC link voltage drops to a value smaller than 300 V within this period, the message „ready-to-operate supply unit“ is immediately reset. Then the message WARNING is set and immediately is reset again, because the message „ready-to-operate supply unit“ is not available anymore.



NOTE

After switching on the +24 V supply voltage, the releasing of the monitoring function mains failure is saved only then, if:

the **mains** is detected as „correct“ and the **DC link dropped under 300 V**.

In order to achieve an independent starting e. g. after mains interruption, by a continuously control of the reset input (apply +24V and M24V at X99AB, optocoupler input) in order to avoid the saving of the messages (precondition is, that the mains failure time is set to > 0 seconds. See „mains failure time“ in the controller description).

WARNING

The following **can occur**, if you disregard this warning instruction:

- serious personal injury • death



*The danger is: **mechanical effects.***

execute protection on the motor side, if an automatic restarting of the drive is possible - because of the automatic restart the operating personal is subject to potential injury!

- **Monitoring function short-circuit chopper resistor output**

The connection for the external chopper resistor is monitored.

If the monitoring function detects a connection for the external chopper resistor a short-circuit, the message „short-circuit chopper resistor output“ is generated. This message is saved and the message „ready-to-operate supply unit“ is reset.



WARNING

The following **can occur**, if you disregard this warning instruction:

- serious personal injury • death

At short-circuit of chopper resistor output the unit can be destroyed.

8.4.2 Monitoring functions motor-sided power unit

A preliminary information according these monitoring functions are in [►Monitoring functions supply unit◄](#) on page 74. There are 6 (optional 7) monitoring functions of the motor-sided power unit. In the following the monitoring functions motor-sided power unit are explained in detail.

- **Monitoring function overcurrent (motor)**

Every of the three phase currents of the motor are monitored. In case of an exceeding of the phase current of 30% of the amplitude of the permissible peak current the unit generates a message. This message is saved in the unit and is transferred to the controller. This message 'Ready-to-operate motor-sided power unit' is reset.



NOTE

The overcurrent message and the consequential stopping of the drive protects this of damage/destruction. In order to avoid the message 'overcurrent (motor)', you must limit the permissible peak current of the motor phase currents by the control system.

- **Monitoring function ground current (short-circuit)**

The ground fault current of the motor phases is monitored. A message is generated, if the error current exceeds 20% of the amplitude of the permissible peak current of the power unit. As a cause of error an ground fault at the motor connection is likely. This message is transferred to the controller. This message 'Ready-to-operate motor-sided power unit' is reset.

- **Monitoring function overcurrent**

The level of the voltage is monitored. If the DC link voltage reaches 800 V, a message is generated. This message is transferred to the controller. This message 'Ready-to-operate motor-sided power unit' is reset.



NOTE

The voltage can increase until switch-off takes place, if the drive brakes and if there is no or too little chopper circuit at the DC link.

- **Monitoring function power transistors**

The collector-emitter-saturation voltage is monitored. If the voltage is too high, an overcurrent of the power transistor is present, for example by a short-circuit of the motor terminals and a controlled switch-off operation, which switches off the transistor and generates a message. This message is transferred to the controller. This message 'Ready-to-operate motor-sided power unit' is reset.

**NOTE**

In order to guarantee a recovery of the transistor after a switching-off because of overcurrent, the message can be reset not until after five (typical 10 s).

- **Monitoring function overtemperature heatsink**

The temperature of the heatsink is monitored. On the heatsink there is a linear temperature sensor, whose measured value is routed onto the controller. The controller therewith takes over the temperature monitoring (see description of the controller). The temperature monitoring must be set in accordance with the specifications in the controller descriptions. If an overtemperature was determined at a heatsink, the controller resets the message „ready-to-operate power unit“.

**CAUTION**

The following **can occur**, if you disregard this warning instruction:

- Property damage

*The danger is: **temperature of unit too high**. The maximum permissible temperature of the heatsink is 90 °C - if there is a higher temperature the device can be destructed.*

Set the controller in such a way, that the 'ready-to-operate motor-sided power unit' is reset by the controller at a temperature of the heatsink of 85 - 90 °C.

- **Monitoring function internal auxiliary supply**

The voltage, which is necessary for the activation of the power transistors is monitored. If the internal auxiliary supply is missing, a message is generated. This message is transferred to the controller and the controller then resets the message „ready-to-operate motor-sided power-unit“.







- **Safety relay (option)**

The output status of the safety relay is monitored.

Additional data referring to the safety relay is available in [▶Messages via relay contacts◀](#) on page 83 and in [▶Appendix E - Safety relay◀](#) on page 115.

8.4 Monitoring functions

8.4.3 Messages via LEDs

LED	Description
<p>PELV</p>  <ul style="list-style-type: none"> — PELV — READY — WARNING — TEMP.> — PHASE ERR. — POWER ERR. — BRAKE OVERL. 	<p>Protective extra-low voltage +24 V green LED off: At the plug-in terminal X99A or X99B the following is applied at the terminals: 1.2: no +24 V 3.4: no 24 V reference potential</p> <p>green LED on: At the plug-in terminal X99A or X99B the following is applied to the terminals: 1.2: +24 V 3.4: 24 V reference potential</p>
<p>READY</p>  <ul style="list-style-type: none"> — PELV — READY — WARNING — TEMP.> — PHASE ERR. — POWER ERR. — BRAKE OVERL. 	<p>„ready-to-operate supply unit“ ¹⁾ green LED on: The message 'ready-to-operate supply unit' is present.</p> <p>Additional data according message 'ready-to-operate power unit' is available in ▶'Ready-to-operate supply unit'◀ on page 76.</p>
<p>WARNING</p>  <ul style="list-style-type: none"> — PELV — READY — WARNING — TEMP.> — PHASE ERR. — POWER ERR. — BRAKE OVERL. 	<p>Warning yellow LED on: The message WARNING is present.</p> <p>In which case this message is generated, please read in ▶Monitoring function phase failure◀ on page 78 and ▶Monitoring function mains failure◀ on page 78.</p>
<p>TEMP. ></p>  <ul style="list-style-type: none"> — PELV — READY — WARNING — TEMP.> — PHASE ERR. — POWER ERR. — BRAKE OVERL. 	<p>Overtemperature The red LED is always off - it does not play a role on this device.</p>
<p>PHASE ERR.</p>  <ul style="list-style-type: none"> — PELV — READY — WARNING — TEMP.> — PHASE ERR. — POWER ERR. — BRAKE OVERL. 	<p>Phase failure red LED on: The message „phase failure“ is present.</p> <p>In which case this message is generated, please read in ▶Monitoring function phase failure◀ on page 78.</p>
<p>POWER ERR.</p>  <ul style="list-style-type: none"> — PELV — READY — WARNING — TEMP.> — PHASE ERR. — POWER ERR. — BRAKE OVERL. 	<p>Mains failure red LED on: The message „failure mains phase“ is present.</p> <p>In which case this message is generated, please read in ▶Monitoring function mains failure◀ on page 78.</p>
<p>BRAKE OVERL.</p>  <ul style="list-style-type: none"> — PELV — READY — WARNING — TEMP.> — PHASE ERR. — POWER ERR. — BRAKE OVERL. 	<p>Short-circuit chopper resistor output (BA+ with BA-) red LED on: The message „short-circuit chopper resistor output “ is present.</p> <p>In which case this message is generated, please read in ▶Monitoring function short-circuit chopper resistor output◀ on page 79.</p>

¹⁾ Also see [▶Messages via relay contacts◀](#) on page 83.

8.4.4 Messages via relay contacts

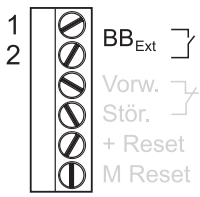
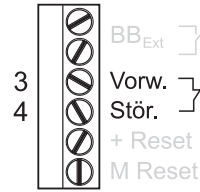
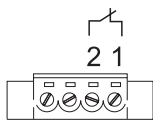
Plug-in terminal	Description
 <p>Figure 33: BB_Ext</p>	<p>'Ready-to-operate supply unit'</p> <p>Contact open: The message 'ready-to-operate supply unit' isn't present.</p> <p>Contact closed: The message 'ready-to-operate supply unit' is present.</p> <p>Additional data according message 'ready-to-operate power unit' is in ►'Ready-to-operate supply unit'◄ on page 76.</p>
 <p>Figure 34: Pre-warn- ing/error</p>	<p>Pre-warning -error (pre-warning is actually the wrong expression, warning would be correct)</p> <p>Contact closed: The message WARNING isn't present.</p> <p>Contact open: The message WARNING is present.</p> <p>In which case this message is generated, please read in ►Monitoring function phase failure◄ on page 78 and ►Monitoring function mains failure◄ on page 78.</p>
 <p>Figure 35: X68</p>	<p>The safety relay can be used to disconnect the motor from the unit. After the disconnection the motor is zero-torque, but isn't isolated from the unit. Due to the fact that the motor is not isolated from the unit, the motor is not off-circuit!</p> <p>A typical application for the safety relay is: ► very quick reuptake of the operation after switching off This is possible, because the DC link voltage is not switched off.</p> <p>Resetting safety relay (safety relay is optional available) Contact closed: +24V-supply for the safety relay is missing. The output stage or the inverter is inhibited.</p> <p>Contact open: +24V supply for the safety relay is existing. The output stage or the inverter can be controlled by the controller.</p> <p>If the +24 V supply for the safety relay is taken away, while the drive is running, then the drive is immediately switched zero-torque (this means the device doesn't supply any power anymore). In order to start the drive again you must obey the following procedure: Switch on +24V supply for safety relay Delete existing message by a reset of the controller</p>

MAINTENANCE

The maintenance of devices is the checking. If checking is carried out accurately problems can be avoided in time.

9.1 Inspection intervals

In the case of polluted environmental air, the required cooling air flow rate can not be reached anymore, if dirt deposits block the ventilation slots.

But already beforehand there can be dirt deposits in the inside of the device, which avoid the required heat dissipation. Dirt deposits at the ventilation slots are a warning signal, which attention must be paid to.

- Check the equipment at the control cabinet, which ensure the required environmental conditions (e.g. air filters) and maintain, if necessary according to the indications of the manufacturer.
- Check weekly the specified environmental conditions.

The prescribed environmental conditions are to be found in chapter [►Appendix D - Technical data◄](#) from page 107.

- Check monthly the mixing ratio of anti-corrosion protection (only valid for version F)

REPAIR



DANGER

The following **will occur**, if you disregard this safety information:

- serious personal injury
- death

Make sure, that only Baumüller personnel, who is familiar with the safety- as well as with mounting-, operating- and maintenance instructions, works on this unit.

This unit is carrying dangerous voltage - all repair workings must be executed if the unit is off-circuit.

Begin workings at the of the unit, not until it has been assured that neither potential nor voltage (residual charge) is present.

Before demounting safety equipment for commissioning or repair set the machine in exact accordance with the instructions out of operation. Directly after completion of commissioning or repair works you must mount the safety equipment again and ensure its function.



NOTE

The operator of the machine must make an acceptance test of the total drive and must document this in a maintenance schedule protocol chronological (maintenance log), after each intervention in the drive, it doesn't matter if in the motor, in the actual value sensing or in the power unit. If this is disregarded, the operator runs the risk of liability consequences.



11

SHUTDOWN, STORAGE

In this chapter we describe, how to set BUM62 S/A/F out of operation and the storage afterwards.

11.1 Requirements to the executing personnel

The personnel, who is appointed to setting out of operation, must have the required knowledge and instructions, which is necessary for an execution according to the rules. Select the personnel in such a way, that the safety instructions, which are mounted to the device and its parts as well as to the connections, are understood and applied to.

11.2 Safety instructions

The safety instructions which are valid for commissioning also must be applied to, when setting out of operation.



DANGER

The following **will occur**, if you disregard this safety information:

- serious personal injury • death

*The danger is: **electricity**.*



Assure, that all electrical connections are off-circuit and are well protected against unintentional restart.

*The containing components in the device (e. g. capacitors) can contain dangerous charges! At the earliest **10 min.** after switching off the supply voltage, the capacitors in the device are automatically discharged.*

Before workings at the electrical connections with suitable measuring devices check, that the connections are off-circuit and demount the cables not until you are convinced of the isolation of supply.

11.3 Shutdown

Setting out of operation is divided into the following steps:

- 1 Switch to off-circuit status and assure against unintentional reactivation.
- 2 (approx. 10 min after switching off) check isolation of supply of connections.
- 3 Demount connection and assure them according to safety instructions.
- 4 If necessary: demount and close cooling circuits.
- 5 Document the setting out of operation.

11.4 Demounting

The demounting assumes a completed, documented setting out of operation.

When demounting, the same instructions and safety notes must be obeyed as when „mounting“. Thereby consider, that a BUM62 S/A/F weighs about 35 kg and provide for equipment for transportation (hoisting devices, cranes, transportation staff a. s. o.) after demounting.

Enable all mechanical connections to the control cabinet not until the device has been protected against dropping/falling out.

Provide suitable packing, if the devices are stored, in doubt ask Baumüller Nürnberg GmbH. At transportation pay attention to, that the device is not damaged by wrong storage or severe shocks, also see [►Packing and Transportation◄](#) from page 21.

11.5 Storage conditions

The duration of storage is unlimited, if you adhere to the following storage conditions:

- 1 K 4 (climatic category)
- - 30 °C bis + 70 °C (temperature range)

11.6 Maintenance during storage

During storage no maintenance is required.

11.7 Recommissioning

- 1 Change the seal (only at BUM62 A/F)
- 2 Execute commissioning as with a new device.

In case you have stored the unit longer than six months, the capacitors must be reformed before recommissioning. Therefor you must supply the device for at least 48 hours ready-to-operate with supply voltage without pulse enable.

12

DISPOSAL

In this chapter we describe the correct and safe disposal of the BUM62 S/A/F devices. During the disposal you will mainly get metal parts (iron- and non-iron metal), electrical scrap and plastics.

12.1 Safety instructions

You must only dispose under consideration of the safety instructions. If necessary, also refer to the local regulations. In case you cannot execute a secure disposal, contact a certified disposal business.

CAUTION



The following **can occur**, if you disregard this warning instruction:

- Environmental pollution



*The danger is: **incorrect disposal.***

Dangerous materials may result or may be set free from a fire.

Do not expose electronic components to high temperatures.

As an inner insulation of e.g. various power semiconductors beryllium oxide is used. When opened, the beryllium dust is dangerous to your health.

Do not open the electrical components.

12.2 Requirements to the executing personnel

The personnel, whom you instruct to dispose/demount the device must have the knowledge and training to execute these works properly. The personnel is to be selected in such a way, that the safety instructions on the device and its parts is understood and referred to by the personnel.

12.3 Disposal instructions

- Preconditions**
- The device has already properly been demounted.
 - All technical devices are prepared and are technically in a good order and condition.

12.3.1 Modules

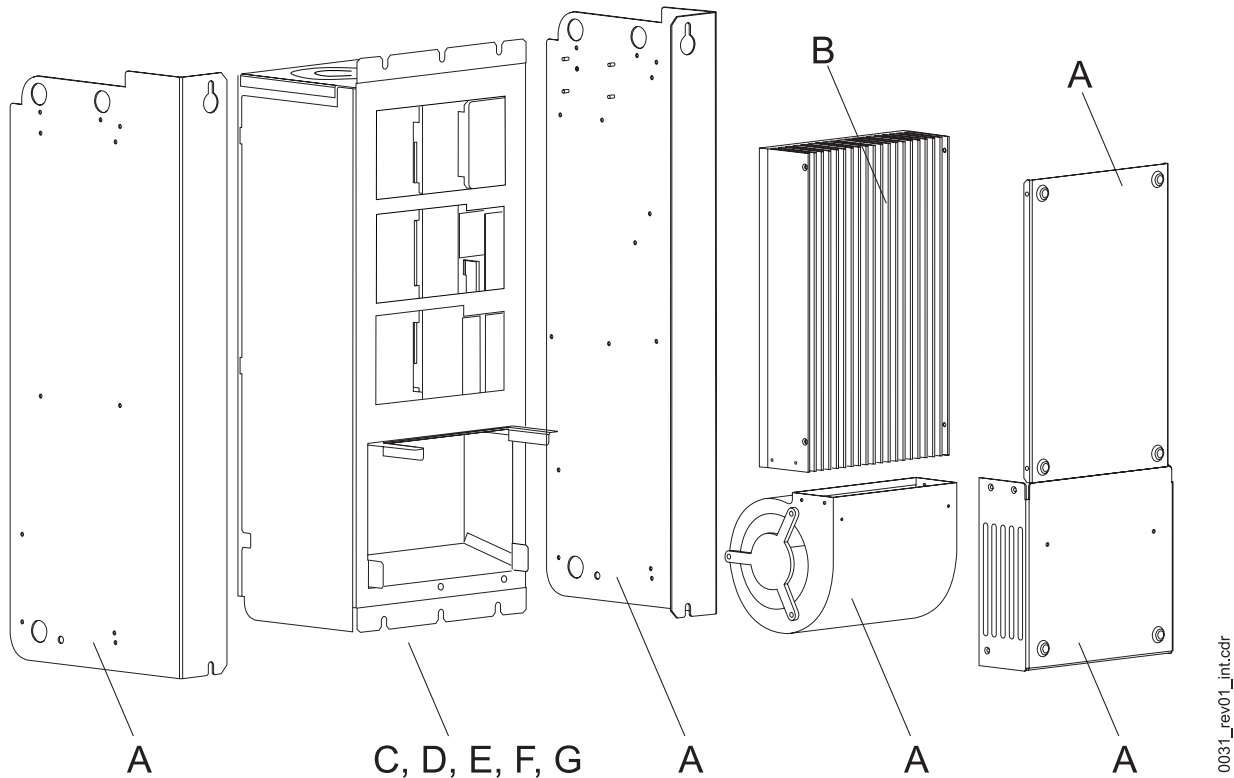

Figure 36: Demounting scheme

The components/modules given in round brackets you will find in the figure.

- | | |
|----------------------------------|--|
| Sheet steel | (A) Sheet steel must be given to the iron metal recycling. |
| Aluminium | (B) Aluminium must be given to the non-iron metal recycling. |
| Aluminium/copper compound | (C) Aluminium/copper compound must be given to the non-iron metal recycling. |
| Plastics | (D) The plastic parts of the housing as well as the plastic covers and further small plastic parts must be given to the plastics recycling. |

**CAUTION**

The following **can occur**, if you disregard this warning instruction:

- Environmental pollution

*The danger is: **incorrect disposal.***

The following parts/modules are disposed as special waste.

Capacitors	(E) Capacitors are to be recycled as special waste. Thereby refer to the relevant instructions.
Semiconductor modules	(F) Semiconductor modules are to be recycled as special waste. Thereby refer to the relevant instructions.
Electronic scrap	(G) The electronic scrap from PCBs, which no further can be demounted, must be recycled as special waste. Thereby refer to the relevant instructions.

12.4 Recycling plants/offices

Assure, that the disposal is carried out according to your company's regulations and the regulations of the disposal companies and official administrations. In case of doubt, contact the local business administration, which is responsible for your company or the environmental office.



APPENDIX A - ABBREVIATIONS

Para.	Paragraph	ID-No	Identification number
AC	Alternating current	I_F	Field current
BAPS	Baumüller drives parallel link	I_{FMax}	Maximum field current (nominal current)
BASS	Baumüller drives serial link	I_{Fmin}	Minimum field current
BB	ready-to-operate	I_{Fsoll}	Field current setpoint
BBext	ready to operate (external)	Inc	Counting unit of position
BBint	ready-to-operate (internal)	IND	index
BSA	Reference potential analog	Ink	PPR count of incremental encoder
BSD	Reference potential digital	INK.	Incremental
BSE	Reference external for 24V-control inputs	I_{set}	Armature current setpoint
BUB	Chopper resistor unit	LED	Light-emitting diode
BUC	Baumüller supply/recovery unit	M24	Reference potential 24 V
BUG	Baumüller converter basic-supply-unit	MR1	Torque direction 1
BUM	Baumüller single-power-unit	MR2	Torque direction 2
BUS	Baumüller power module	mtr.	Medium time-lag
DA	digital/analog	n = 0	Speed = 0
DC	► Direct current ► drive control	N	Function module speed controller
DIN	Deutsches Institut für Normung e.V. (German Institute for Standardization)	n_{is}	Speed actual value
EMF	Electromagnetic constant	n_{Max}	Maximum speed
EMC	Electromagnetic compatibility	n_{min}	Minimum speed
EN	European standard	NN	Altitude
EXT, ext	External	n_{soll}	Speed setpoint
FI	Residual current	P	Identification number
HE	Main contactor ON	PELV	Protective extra-low voltage with safety separation, grounded
HS	Main contactor	PZD	Process data
HSE	Main contactor on	R	Reserved
HSF	Main contactor enable	RF	Controller enable
		RS	Controller inhibit
		SE	Shield ground

SELV	Safety extra-low voltage with safety separation
SH	Quickstop
SL	Protective conductor
SM	Synchronous motor
SWK	Setpoint channel
TBA	Overtemperature chopper resistor
TKK	Overtemperature heatsink
TM	Temperature motor
TMO	Overtemperature motor
U_A	Armature voltage
UVS	Supply voltage too low
USS[®]	trade-mark Siemens, universal serial interface
U_{ZK}	voltage
VBG	German Administrative Occupation Co-operative
VDE	Association For Electrical, Electronic & Information Technologies
X	Terminal strip
ZK	DC link



APPENDIX B - ACCESSORIES



B.1 Connector

Item	Part No	Manufacturer - order No Type
Connector for X99 A	00309454	Phoenix Contact - MVSTBW 2.5/6-ST
Connector for X99 AB	00309455	Phoenix Contact - MVSTBR 2,5/6-ST
Connector for X68	00309482	Phoenix Contact - MC 1,5/4-STF-3,81-BD:1-4
Connector for X90	00313767	Phoenix Contact - MC 1.5/2-STF-3.81

B.2 Fuse

General information according fuses is to be found in [►D.4 Fuse protection◄](#) on page 113.



















B.2.1 Full-range fuses gR, gRL, gR/gS, gGR (device and cable), model NH

Bussmann	00	80A/690V: 170M2699	100A/690V: 170M2700
		125A/690V: 170M2701 ¹⁾	
	1	80A/690V: 170M4178	100A/690V: 170M4179
		125A/690V: 170M4180	
Ferraz Shawmut	000	80A/690V: 6.9 GGR 000 PV 080/ 6,9 GGR 000 D08L 080	
	00	80A/690V: 6.9 GGR 00 PV 080/ 6,9 GGR 00 D08L 080	
SIBA	1	80A/690V: 2021120-80A	100A/690V: 2021120-100A
		80A/690V: 2021134-80A 	100A/690V: 2021134-100A  ¹⁾
Siemens	000	80A/690V: 3NE1 820-0 	

Size

¹⁾ For the connection of an additional DC link capacity or the parallel operation of up to five devices suitable, that means the DC link of several devices is connected with at the same time existent mains connection of every device.

B.2.2 Semiconductors aR (device), model NH

Bussmann	000	80A/690V: 170M1566 	100A/690V: 170M1567 
		125A/690V: 170M1568 	
	00	80A/1000V: 170M2680	100A/1000V: 170M2681
		125A/1000V: 170M2682	
	1	80A/690V: 170M3811 	100A/690V: 170M3812 
		125A/690V: 170M3813 	
SIBA	1	125A/690V: 2021120/125A ¹⁾	
		125A/690V: 2021134/125A 	
Siemens	000	80A/690V: 3NE8 720-1 	100A/690V: 3NE8 721-1 
		125A/690V: 3NE8 722-1 	
	00	80A/690V: 3NE8 020-1 	100A/690V: 3NE8 021-1 
		125A/690V: 3NE8 022-1 	
	0	80A/1000V: 3NE4 120 	100A/1000V: 3NE4 121 
		125A/1000V: 3NE4 122 	
	1	100A/1000V: 3NE3 221 	125A/1000V: 3NE3 222 

Size

For the connection of an additional DC link capacity or the parallel operation of up to five devices suitable, that means the DC link of several devices is connected with at the same time existent mains connection of every device.

B.3 EMC accessories

Mains filters for TN-mains

$I_{\text{Rated AC}}^{1)}$	Type	Part No
75 A	BFN 3-1 - 75 - 001	314282
100 A	BFN 3-1 - 100 - 001	314283

Mains filter for IT- and grounded delta mains

$I_{\text{Rated AC}}^{1)}$	Type	Part No
250 A	BFN 3-1 - 250 - 002	373620

¹⁾ Rated temperature = 40° C



APPENDIX C - DECLARATION OF CONFORMITY / MANUFACTURER / UL-CERTIFICATION

In this section we provide general information about EU directives, the CE symbol and the Declaration of Conformity/by Manufacturer.

C.1 What is an EU directive?

EU directives specify requirements. The directives are written by the relevant bodies within the EU and are implemented by all the member countries of the EU in national law. In this way the EU directives guarantee free trade within the EU.

An EU directive only contains essential minimum requirements. You will find detailed requirements in standards, to which references are made in the directive.

C.2 What the CE symbol indicates

a) The CE marking symbolizes conformity to all the obligations incumbent on manufacturers for the product by virtue of the Community directives providing for its affixing.

...

b) The CE marking affixed to industrial products symbolizes the fact that the natural or legal person having affixed or been responsible for the affixing of the said marking has verified that the product conforms to all the Community total harmonization provisions which apply to it and has been the subject of the appropriate conformity evaluation procedures.

...

Council Decision 93/465/EEC, Annex I B. a) + c)

We affix the CE mark to the equipment and to the documentation as soon as we have established that we have satisfied the requirements of the relevant directives.

All converters and control systems supplied by the Baumüller Nürnberg GmbH satisfy the requirements of 73/23/EEC (Low Voltage Directive).

As all converters and control systems comply with the requirements of the harmonized standards EN50178, EN 60204-1, EN 60529 and HD625.1 S1, the protection targets of 73/23/EWG are reached.

With specified application of this Baumüller equipment in your machinery, you can act on the assumption that the equipment satisfies the requirements of 98/37/EG (machinery directive). Therefore the equipment is developed and constructed in such a way, that the requirements of the harmonized standard EN 60204-1 can be met by the electrical installation.

Compliance with 89/336/EEC (EMC Directive) depends on how the equipment is installed. Since you are performing installation yourself, it is you who are responsible for complying with 89/336/EEC.

A declaration of conformity on the EMC directive therefore cannot be issued.

We will provide you with support in the form of EMC information. You will find this information in the operating manual and in “filters for main applications”. When you have complied with all the requirements we impose in this documentation, you can assume that the drive satisfies the requirements of the EMC Directive.

The limit values and requirements for variable-speed electrical drives are determined in the harmonized product standard EN61800-3. If you are erecting an installation, for which a declaration of conformity on the EMC directive must be generated, it may be necessary to specify several harmonized standards, which you have used for the compliance of the protection targets of the directive. The harmonized product standard EN 61800-3 has to be used with electrical drives.

To enable you to market your machine within the EU, you must be in possession of the following:

- Conformity mark (CE mark)
- Declaration(s) of Conformity regarding the directive(s) relevant to the machine

C.3 Definition of the term Declaration of Conformity

A Declaration of Conformity as defined by this documentation is a declaration that the electrical equipment brought into circulation conforms to all the relevant fundamental safety and health requirements.

By issuing the Declaration of Conformity in this section the Baumüller Nürnberg GmbH declares that the equipment conforms to the relevant fundamental safety and health requirements resulting from the directives and standards which are listed in the Declaration of Conformity.

C.4 Definition of the term Declaration by Manufacturer

A Declaration by Manufacturer as defined by this documentation is a declaration that the machine/safety component brought into circulation conforms to all the relevant fundamental safety and health requirements.

By issuing the Declaration of Conformity in this section the Baumüller Nürnberg GmbH declares that the equipment conforms to the relevant fundamental safety and health requirements resulting from the directives and standards which are listed in the Declaration of Conformity .

The Baumüller equipment is integrated into a machine. For health and safety, of the users for example, it is important for the entire machine to conform to all the relevant fundamental safety and health requirements. For this reason the Baumüller Nürnberg GmbH draws attention in the Declaration by Manufacturer to the fact that it is prohibited to put the machine as a whole into operation before it has been declared that the machine conforms to the provisions of the Machinery Directive.

C.5 Declaration of conformity

EU-Konformitätserklärung

Declaration of Conformity

gemäß EU-Richtlinie 73/23/EG (Niederspannung) vom 19.02.1973

geändert durch: 93/68/EWG vom 22.07.1993

in accordance with EC directive 73/23/EG (low voltage) dated 19.02.1973

changed by: 93/68/EWG dated 22.07.1993

BUM62-XXX/XXX-XX-X-X-XXX

BUM62S-XXX/XXX-XX-X-X-XXX

BUM62A-XXX/XXX-XX-X-X-XXX

BUM62F-XXX/XXX-XX-X-X-XXX

Das obige Gerät wurde entwickelt und konstruiert sowie anschließend gefertigt in Übereinstimmung mit o.g. EG-Richtlinie und u.g. Normen in alleiniger Verantwortung von:

The unit specified above was developed and constructed as well as manufactured in accordance with the above mentioned directive and the standards mentioned below under liability of:

Baumüller Nürnberg GmbH, Ostendstr. 80 - 90, D-90482 Nürnberg

Berücksichtigte Normen - standards complied with:

Norm / standard

EN 50178	Ausrüstung von Starkstromanlagen mit elektrischen Betriebsmitteln Electronic equipment for use in power installations
EN 60204-1	Sicherheit von Maschinen - Elektrische Ausrüstung von Maschinen Safety of machinery - Electrical equipment of machines
EN 60529	Schutzarten durch Gehäuse (IP Code) Degrees of protection provided by enclosures (IP Code)
HD 625.1 S1	Isolationskoordination für elektrische Betriebsmittel in Niederspannungsanlagen Insulation coordination for equipment within low-voltage systems

Nürnberg, 28.09.2006

Andreas Baumüller
Geschäftsführer
Head Division

ppa. Dr. Heidrich
Entwicklungsleiter
Head of development

C.6 Declaration by manufacturer

EU-Herstellererklärung

Declaration by Manufacturer

gemäß EU-Richtlinie 98/37/EG (Maschinen) vom 22.06.1998

geändert durch: 98/79/EG vom 27.10.1998

in accordance with EC directive 98/37/EG (machinery) dated 22.06.1998

changed by: 98/79/EC dated 27.10.1998

BUM62-XXX/XXX-XX-X-X-XXX

BUM62S-XXX/XXX-XX-X-X-XXX

BUM62A-XXX/XXX-XX-X-X-XXX

BUM62F-XXX/XXX-XX-X-X-XXX

Die Inbetriebnahme der Maschine, in die dieses Gerät eingebaut wird, ist untersagt bis die Konformität der Maschine mit der obengenannten Richtlinie erklärt ist.

The machinery into which this unit is to be incorporated must not be put into service until the machinery has been declared in conformity with the provisions of the directive mentioned.

Bei der Entwicklung und Konstruktion des Geräts wurden folgende Normen beachtet:

The development and construction of the unit is complied with following standards:

Norm / standard

EN 60204-1	Sicherheit von Maschinen - Elektrische Ausrüstung von Maschinen Safety of machinery - Electrical equipment of machines
------------	---

Baumüller Nürnberg GmbH, Ostendstr. 80 - 90, D- 90482 Nürnberg

Nürnberg, 28.09.2006

Andreas Baumüller
Geschäftsführer
Head of division



ppa. Dr. Heidrich
Entwicklungsleiter
Head of development

C.7 UL certification





UL is a mark of conformity, which is assigned from **Underwriters Laboratories Inc.** (www.ul.com), an American company. The UL-certification is not statutory regulated, but takes place voluntarily.

In order to be allowed to mark equipment and components with the UL-mark of conformity, tests must have to be done, which are attended and documented by an UL-inspector. Only if all necessary tests have been passed and regular product monitoring at the production process of the equipment or the components has been passed without objections, the UL-mark of conformity may be attached to the equipment under test.

Line filters of the company **Baumüller Nürnberg GmbH** are checked in accordance of the UL-standard UL 508C (UL-Standard for Safety for Power Conversion Equipment) and are recorded under the category control number NMMS. The product- and test description is recorded under file-no. E179860.

Only if all necessary tests have been completely carried out the -mark may be attached to the equipment or components. If single tests have not already taken place at the manufacturer's, but are carried out not until at the user's, then only the -mark may be attached.

With products of the **Baumüller Nürnberg GmbH** all tests are already completed at the UL-certification process, so that they may be marked with the -mark.

In case with the UL-certification process also standards of the CSA (Canadian **S**tandard **A**ssociation) are considered, then instead of the - or -mark the  or -mark may be attached to the product.

With products of the company **Baumüller Nürnberg GmbH**. the CSA-standard Norm C 22.2 was considered, that's why they are marked with the -mark.

If products of **Baumüller Nürnberg GmbH**. are mounted into an UL-certified installation, then certain application-, mounting- and installation notices must be considered, which are upon the functioning of the device. We have marked these notes in the manual with „UL 508C ...“. Only if you follow these notes and apply to them you may go by it, that the installation has been mounted UL-conform.



APPENDIX D - TECHNICAL DATA

In this appendix you will find a survey of the technical data. Some of this data we have used in the previous chapters at the accordant positions.

D.1 Requirements on the power supply

D.1 Requirements on the power supply

Mains	Industrial system with direct or low impedance grounded star point (TN-mains or TT-mains) Industrial supply network with no or high impedance grounded star point (IT mains) Industrial system with direct or low impedance grounded corner point (grounded delta wye)
Total inductance at the device connection (sum of mains inductance and mains choke inductance)	min. $U_k = 4\%$ max. $U_k = 6\%$
Rated mains input voltage/-frequency	3 x 400 V / 50/60 Hz
Mains voltage/-frequency ^{1) 2)} Device (U_{AC})	BUM 62 S/A/F: min. 3 x 360 V / 48 to 62 Hz max. 3 x 528 V / 48 to 62 Hz BUM 62-70/200: min. 3 x 360 V / 48 to 62 Hz max. 3 x 506 V / 48 to 62 Hz
Harmonics (mains voltage)	THD < 10% ³⁾
Unbalanced mains voltage	max. 3% ⁴⁾
Voltage dip	Depth of dip < 40%, area < 250% x degree ⁵⁾
Control voltage ⁶⁾ (U_{DC})	+ 24 V -15% / +20% ⁷⁾

¹⁾ At voltage interrupts ($0,7U_B > U > 0,1U_B$ for $t > 0,1$ sec.) (U = mains voltage) the error 'Phase failure' or 'Mains failure' is generated (also see [Monitoring functions](#) from page 77).

²⁾ The rated voltage is 400 V. At mains voltages that are smaller 400 V the output power of the device reduces (see curves).

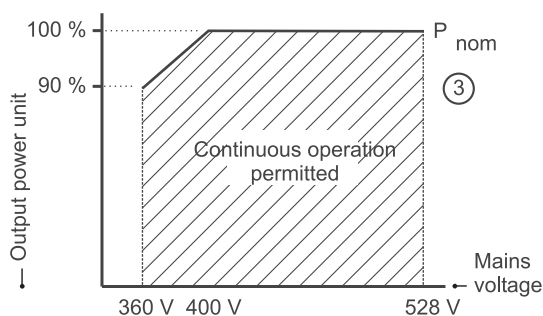
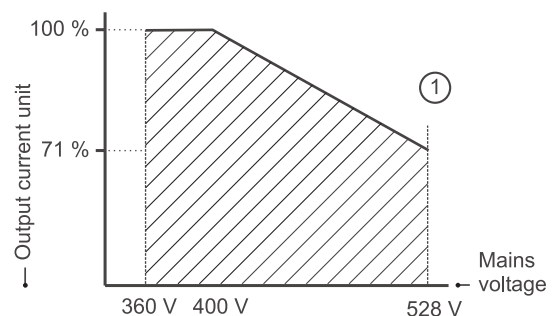
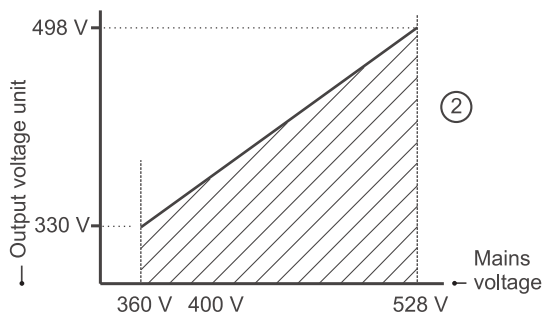

① Curve 'Output current'

② ' Curve 'Output voltage'

③ If the output current is multiplied with output voltage the output power is obtained. In order to obtain the specified curve/surface, it is necessary, that the output current is reduced between 400 and 528 volt.

- 3) EN 61800-3, chapter 5.2.1
- 4) EN 61000-2-4, tab. 1, class 3
- 5) EN 61800-3, chapter 5.2.2
- 6) The supply voltage must be accordant to PELV (EN 50178, chapter 3.70).
At supply voltage of < 24 V the ventilation power output is reduced.
It, therefore, may be necessary, to reduce the output currents as well.
- 7) EN61131-2: 1994, table 6

D.2 Required environmental conditions

Transportation temperature range	- 30 °C bis + 70 °C
Transportation climatic category	2 K 3 ¹⁾
Storage temperature range	- 30 °C bis + 70 °C
Storage climatic class	1 K 4 ¹⁾
Operational environment	outside of residential areas ²⁾
Operation temperature range	min. 0 °C bis max. 55 °C ³⁾
Operation climatic class	3 K 3 ¹⁾
Mounting height ⁴⁾	absolute altitude up to 2000 m (rated duty at 1000 mm over sea level)
Relative humidity (operation)	5% to 85% no condensation ¹⁾
Ionized and non-ionized radiation	no limit
Vibration, shock and repetitive shock	max. 1 g ⁵⁾
Degree of pollution	2 ⁶⁾
Cooling air temperature ⁸⁾ Cooling water temperature ⁷⁾	min. 0 °C to max. 55 °C ³⁾ min. 'cooling air temperature ⁹⁾ ' to max. 60 °C
Cooling air requirement (power heat sink) ¹⁰⁾	m ³ / h
Cooling air requirement (interior space of device) ¹⁰⁾	135 m ³ / h
Cooling water flow rate ⁷⁾	min. 4 l/min. to max. 10 L/min.
Cooling water pressure ⁷⁾	max. 6 bar
Temperature difference (cooling water inlet to-outlet)	8.5 K at 4 l/min at rated operation
Pressure loss at water cooler ⁷⁾	Version F: 1.15 bar at 4 l/min

¹⁾ EN 50178, table 7

²⁾ at use in residential areas you must reckon that there are high frequency disturbances (EN 61800-3, 6.3.2.3)

³⁾ 40° is the rated temperature

D.2 Required environmental conditions

- 4) Characteristic curve: Power output of the device in dependence with the mounting height at normal pressure

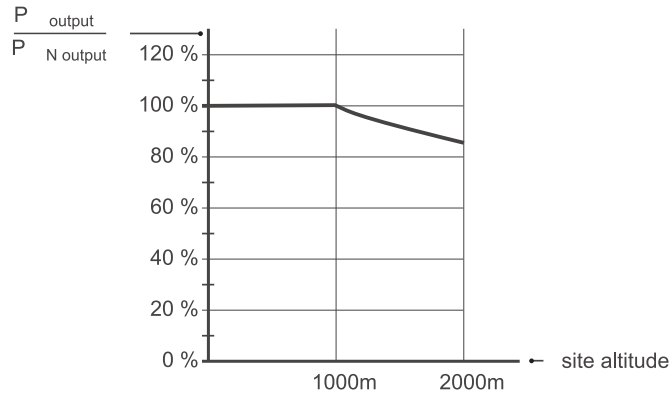

- 5) EN 50178, chapter 9.4.3.2
 6) EN 50178, table 2
 7) The cooling water must meet the following requirements:

pH-value	6.5 to 9.5	Manganese (Mn)	< 0.05 ppm
Conductivity	< 1.8 ppm	Copper (Cu)	< 0.1 ppm
Total water hardness (incl. CaCO ₃)	< 100 ppm	Chlorine (Cl ₂)	< 1 ppm
Suspended matters	< 10 ppm	Chloride (Cl ⁻)	< 500 ppm
Particle size	< 5 µm	Sulfate (SO ₄ ²⁻)	< 500 ppm
Ryznar Stability Index (RSI)	5.0 to 6.0		

The corrosion-resistant compared with further materials you can take from the DECHEMA-material tables. Use a corrosion-resistant and a closed cooling circuit.

- 8) The cooling air temperature refers to the total suction area, see [►Figure 37◄](#) on page 110.
 9) Air inside the control cabinet.
 10) The cooling air requirement corresponds at least to that of a free-blowing device. Under free blowing an unlimited air inlet and air outlet is to be understood.
 With the mounting of the device into a control cabinet it therefore can be necessary to use additional fans, so that the necessary cooling air requirement is covered (see [►Figure 37◄](#) on page 110). If the necessary cooling air requirement of the power heat sink is not provided, then the output power of the device has to be reduced.

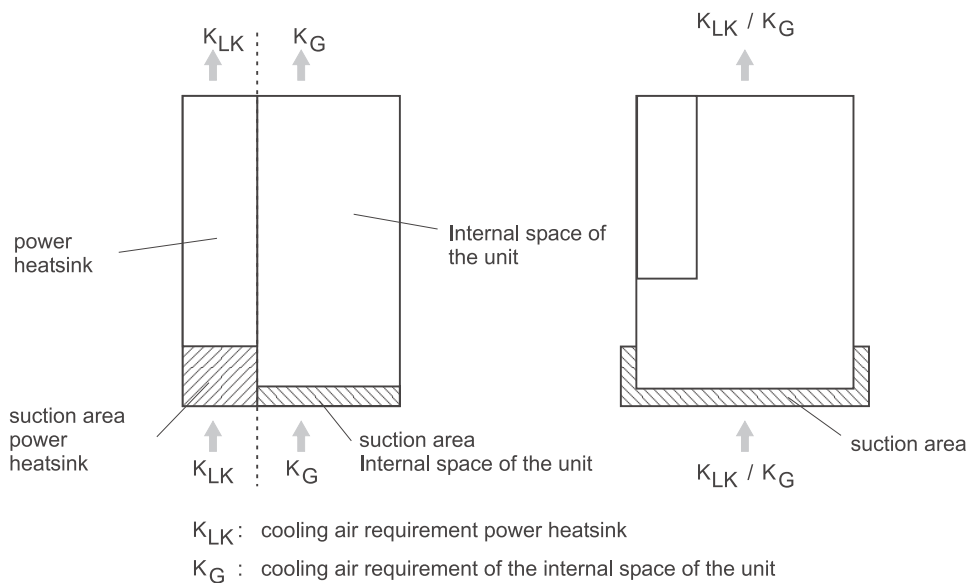

Figure 37: Cooling air requirement

D.3 Electrical data

		BUM62 S/A/F	BUM 62-70/200
Input power 24V ¹⁾		72 W	
DC link voltage ¹⁾ (U _{DC})		540 V	
DC link capacity (internal)		1000 µF	
DC link capacity (external)		2200 µ	19 mF (regard extended charge time!)
Input current, typical at 4 kHz (I _{eff}) ¹⁾		70 A	
Input power, maximum at 4 kHz ⁸⁾ (I _{eff}) ¹⁾		110 A	220 A
Output voltage ²⁾ (U _{AC})		3 x 0 V to 3 x (supply voltage -30 V)	
Output frequency ³⁾		0 Hz bis 300 Hz	
Output frequency ¹⁾	at 4 kHz ⁴⁾	52 kVA	
Output peak power ⁸⁾	at 4 kHz ⁴⁾	67 kVA	138 kVA
Motor power, typical ¹⁾	at 4 kHz ⁴⁾	35 kW	
Output rated current ¹⁾⁵⁾⁶⁾⁷⁾ (I _{AC})	at 4 kHz ⁴⁾	75 A	
Output peak current ¹⁾⁵⁾⁶⁾ (I _{AC})	at 4 kHz ⁴⁾	97.5 A ⁸⁾	200 A ¹⁰⁾
Power supply (1C1/1D1)		36kW	
Chopper resistor current (Î)		max. 73 A	-
Fan power ⁹⁾		max. 200 W	
Chopper resistor external		≥ 11 Ω	-
Chopper start-up voltage (Â)		780 V	-
Power loss 'heatsink' ¹⁾		1410 W	
Power loss 'interior space of device' (with controller, without fan)		200 W	

¹⁾ All rated values refer to a mains input voltage of 400 V and a rated output current (I_{AC}) a control voltage of 24 V and a switching frequency of 4 kHz.

²⁾ The output voltage is a pulsed d.c. voltage. The operating range refers to the effective value of the fundamental wave.

³⁾ The frequency is dependent on the controller, which is used.

⁴⁾ Switching frequency of the inverter. For this see manual of controller.

⁵⁾ Effective value at an environmental temperature of 40 °C.

D.3 Electrical data

- 6) At rated input supply voltage the device supplies the rated-/maximum output currents. At input voltages above the rated input voltage the output currents at constantly output power have to be accordingly reduced.
Characteristic curve: Output current dependent on supply voltage.

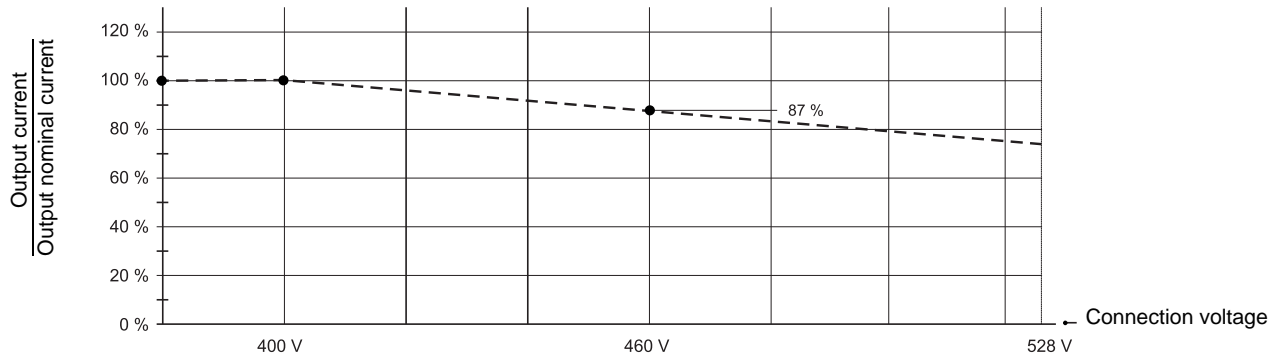

- 7) The output current must be reduced between 40° C and 55° C.
The allowable output current (I_0) is calculated with the following formula:

$$I_e = I_D (40^\circ \text{C}) \cdot \left(1 - \left(\frac{\text{Cooling air temp.}^* - 40^\circ \text{C}}{T_c} \cdot 0.03 \right) \right)$$

*Possibly there are two temperature values (cooling air, which flows through the inner space of the device/cooling air which flows through the heat sink).
Here use the higher value.

Example: output rated current = 150 A, environmental temperature = 46° C

$$I_e = 150 \text{ A} \cdot \left(1 - \left(\frac{46^\circ \text{C} - 40^\circ \text{C}}{T_c} \cdot 0.03 \right) \right) = 150 \text{ A} \cdot 0.82$$

Therewith the output current must be reduced: 123 A

- 8) The peak input power, the peak output power and the peak output current available 120 seconds at maximum. The period is dependent of the prior motor current and of the heatsink temperature. For this see manual of controller.
- 9) is only valid for cooling versions S and A
- 10) for maximum 1 s (at heatsink temperature = environmental temperature)

D.4 Fuse protection



NOTE

In case you consider UL 508C, use semiconductor- or full-range fuses.

Also if you do not consider UL 508C, it is recommended to use semiconductor- or full-range fuses.

Overcurrent protection devices mains cable ¹⁾	in accordance to EN 60204-1
Overcurrent protection devices for device ¹⁾	$I^2t \text{ value} \leq 125,000 \text{ A}^2\text{s}$

¹⁾ Use fuses, which **fall in the operating point below** the stated total operating I^2t value (i^2t).

Consider that there are different types of fuses and that accordant fuse holders must have to be used.

A list of the fuses are to be found in [►B.2.1 Full-range fuses gR, gRL, gR/gS, gGR \(device and cable\), model NH◄](#) on page 98 and [►B.2.2 Semiconductors aR \(device\), model NH◄](#) on page 99.

D.5 BUM62 S - non-electrical data

Dimensions (W x H x D)	328 x 460 x 280 mm
Weight without controller	35 kg
Type of protection	IP 00
Fight fire with	ABC-Pulver

D.6 BUM62 A - non-electrical data

Dimensions (W x H x D)	$368 \times 515 \times (220 + 90)^{1)}$ mm
Weight without controller	35 kg
Type of protection	IP 00/outside IP 44
Fight fire with	ABC-Pulver

¹⁾ The first value is the depth inside the control cabinet. The second value is the depth outside the control cabinet.

D.7 BUM62 F - non-electrical data

Dimensions (W x H x D)	$368 \times 515 \times (220 + 33)^{1)}$ mm
Weight without controller	30 kg
Type of protection	IP 00/outside IP 54
Fight fire with	ABC-Pulver

¹⁾ The first value is the depth inside the control cabinet. The second value is the depth outside the control cabinet.

D.8 Circuit mains - device

D.8 Circuit mains - device

Cross section ¹⁾	dependent on line current
Maximum length mains to mains filter	user-defined
Maximum length mains filter to device	max. 0.3 m (unscreened) max. 5 m (unscreened)
Connection to device	Cable lug

¹⁾ EN 60204, table 5, type of installation C
For UL conform machines/installations you must use UL certified circuit cables.

D.9 Cable control voltage supply/signals

Cross section	2 x 0.2 to 2.5 mm ² (without ferrules) 2 x 0.25 to 2.5 mm ² (with ferrule)
Maximum length	user-defined
Connection to device	flexible, with or without ferrules

D.10 Cables device-motor

Cross section ¹⁾	dependent on connection
Type of cable	screened, shield overlapping > 85%
Maximum length ^{2) 3)}	dependent on the used cross section: up to 4x 25mm ² (AWG 10 to 3): 60m 4 x 35 mm ² (AWG 1): 50m > 4x 50mm ² (AWG 1/0): 15m
Connection to device	Cable lug

¹⁾ EN 60204, table 5, type of installation C
For UL conform machines/installations you must use UL certified circuit cables.

²⁾ Only for Baumüller cables with this maximum length you can act on the assumption, that it is complied with the EMC-regulations.

³⁾ In case you use parallel-installed motor cables, the maximum length is to be reduced by the factor 1/n.

D.11 Electric motor, which has to be connected

Motor type ¹⁾	Three-phase motor (synchronous, asynchronous)
--------------------------	---

¹⁾ dependent on controller



APPENDIX E - SAFETY RELAY

In this chapter we describe the safety relay.

E.1 Methods to avoid an unexpected starting

In order to avoid danger for persons, for example operators, service- and maintenance technics, the machine has to be kept in a safe state (safe stop), while interfering in the dangerous area of the machine. This is why the dependable prevention of an unexpected starting is demanded (amongst others Machine directive 89/392/EEG, attachment I, 1.6.3, last para.; EN 292-2, 4.1.4; EN 60204-1, 5.4). Unexpected approaching is every starting that can cause a risk when appearing unexpected for persons (EN 292-1). Moreover, besides the transition of the enable- to the operating condition of the machine also the unexpected ramp-up of the machine, this means the transition from the safe stop into an unsafe moving has to be considered. This is necessary, because the unexpected ramp-up usually is to be led back to an interruption of the control loop of the machine. Because of its control system, in this case the drive is anxious to achieve highest speed at maximum acceleration. If an unexpected starting occurs, the operator therefore doesn't have the possibility anymore to remove himself or his hand from the danger area. This is why the drive has to be stopped and has to be kept safe in its 'off-position', when having opened, electrical interlocked safety devices. The motor may not have torque and thus cannot generate a dangerous movement.

The prevention of an unexpected starting of the machine can be reached by electrical separated safety devices, e. g. contactors. At some machine types it has to be done without the isolation of the electrical connection of the drive to the mains, if e. g. a drive supplied by a power converter is often stopped and started again. The constant dis- and recharging of the DC link represents a great stress for the concerned parts and often leads to disturbing delays and failures of these parts.

The precondition of starting an three-phase motor is the generation of a rotating field, which drives the inductor of the motor. When having variable-speed three-phase drives, usually in the micro-processors a complex pulse pattern is generated, then the pulses are amplified and are used for the switching of the power semiconductors. If either no defined pulse pattern is available or the amplifying connection is interrupted, e. g. by switching off of the power supply with a relay (safety relay), no rotary field can be generated. An error at the pulse pattern generation therefore cannot lead to a starting of the motor, as long as the second precondition, namely the interruption of the amplifying power supply is available and contrary. The protection against unexpected starting is reached by an electromechanical method which is superior to the electronics. It is reached by a safe isolation - elsewhere than in the load circuit.

The power supply to the windings of the motor is reached at a stoppage by inhibiting the power semiconductor. As semiconductors possibly can fail or be started, because of electromagnetic interferences, the behavior of the shut down drive has to be considered if such an error scenario arises. The fail or 'accidental' turning on of a single or of more power semiconductors at the same pole does not lead to an uncontrolled starting, as no current flow is accomplished. Not until additionally a further power semiconductor is enabled at another pole, current is able to flow through the motor. If, thereby the is directly short-circuited, the fuses which are upstreamed to the converter are tripped, the motor doesn't start. If the is 'short-circuited' over a winding of the motor, a magnetic field can be set up in the motor. If it is an asynchronous motor, then the generated d. c. magnetic properties cannot cause a lurch of the inductor. By the permanent-magnetic synchronous motor the inductor will rotate into a notch position. The therewith angular movement which is covered is dependable of the inductor's position and the number of pole pairs of the motor. It amounts to maximum $180^\circ/\text{number of pole pairs}$. Subsequently the enabled DC link operates like a brake, this means after the ending of the lurching movement the drive is in a blocked state. A starting of the drive is impossible. If a machine with a synchronous motor is planned, the possible sudden movement must be considered, because it can lead to a dangerous movement. Therefore the mechanical engineer must execute a safety evaluation for the residual movement.

The function of the safety relay is limited to the prevention of an unexpected starting. The switching of the safety relay, while the inductor of the motor is rotating, causes an uncontrolled 'coasting' of the machine, a braking with help of the converter is not possible anymore.

WARNING

The following **may occur**, if you disregard these safety notes:

- serious personal injury
- death

*The danger is: **electricity**. Both on the motor and at the unit there can be mains voltage although safety relay is switched off.*

If required, switch the appliance off-circuit like an appliance without a safety relay - the safety relay does not switch the appliance and the motor **off-circuit!**

Switching off the safety relay has no isolation from the supply system as a consequence. Therefore, mains potential can be both at the converter and at the motor. At maintenance, service- and repair workings at electrical components of the drive system therefore the security against electrical dangers must be assured with other means (e. g. main switch).



E.2 Safety categories

Dependent on the possible dangers (these are rated due to the consideration of the severity of the injuries, the frequency of the length of stay within the danger area and possibilities in order to prevent dangers) safety-related components of machines must meet certain safety criteria. The requirements to safety-based parts are divided into five categories in the standard EN 954-1.

In category B basic demands, in 1 additionally safety-technical checked components and principles are claimed. In category 2 an error between inspection intervals can lead to a loss of the safety function.

Category 3 accords to the level 'the single-error-certainty to recognize errors partially'. The safety-related components must be in such a way, that a single error doesn't lead to a loss of the safety function, whereat not the complete possible errors can be self-contained recognized by the system. Therefore an accumulation of unrecognized errors can lead to a loss of the safety function.

Category 4 accords to the level 'Self-monitoring'. This component recognizes self-contained possible errors and signals these in time of the loss of the safety function. Also if up to three from one another independent errors arise the safety function is always maintained.

E.3 The safety relay

The function of the safety relay is executed in fail-safe-technic, also named closed-circuit principle. The safety function 'safe stop' is active, as long as no voltage is applied to the input terminals (X68: 3.4). Consequently the functioning of the safety function is guaranteed if power failure operates. In order to deactivate 'safe stop' a voltage of 24 V must be applied to the terminal, which is concerned (X68: 3.4).

For external monitoring of the safety relay at its positively-driven status signal contacts (X68:1.2) of momentary switch status can be checked. If at the safety relay (X68: 3.4) there is no voltage, that means during the 'safe stop', then the status signal contacts are closed (NC). Also a cable breakage can thusly be recognized as an error.

If the voltage at the input terminals of the relay (X68: 3.4) is switched off, the converter generates one or two error messages (F0204 and/or F0206), which are shown at the V-controller. The drive can only be taken in operation again, if these messages are reset after a reset of the safety relay with a reset signal from the controller (for example by X26, pin programmable or via the interface to a bus system).

The switch-on and switch-off sequence of the enable signals as well as of the safety relay must be considered in order to assure a fault-free operation of the drive.

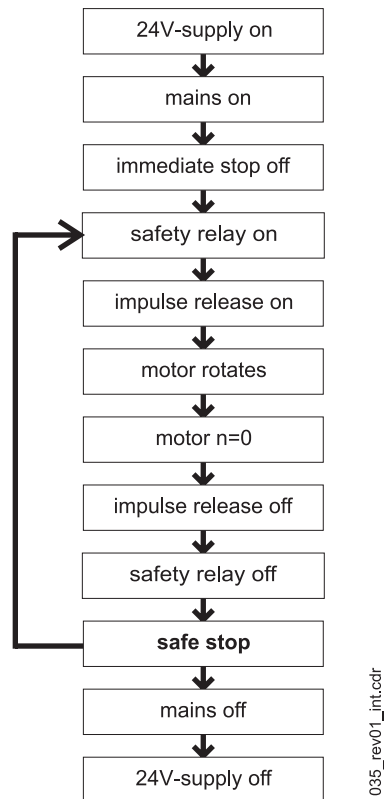

Figure 38: Sequence diagram of safety relay

Baumüller-device of series BUM 6, BUS 6 and BKH, which are executed with a safety relay (optional), comply with the requirements of category 3 (EN 954-1) for the safety-relevant application 'protection against unexpected starting', if the configuring and installation instructions are complied with.

Before the commissioning of the machine, in which the converter with the safety relay is built in, the safety function 'protection against unexpected starting' must be checked. For that purpose a safety device must be executed (for example door contact). The motor must now be zero-torque.

If the reliability performance of the 'protection of unexpected starting' once has been determined, then this safety function of the converter doesn't have to be checked by an external monitoring, as the device checks itself on possible errors and if necessary displays a message as well as switches off the drive.

E.4 Application example for machine of category 3

Exemplary the following diagram shows the usage and cabling of a Baumüller converter of the series BUM 6, BUS 6 or BKH in a machine tool, at which the safe removing of work pieces at opened cover is possible according to category 3 (EN 954-1).

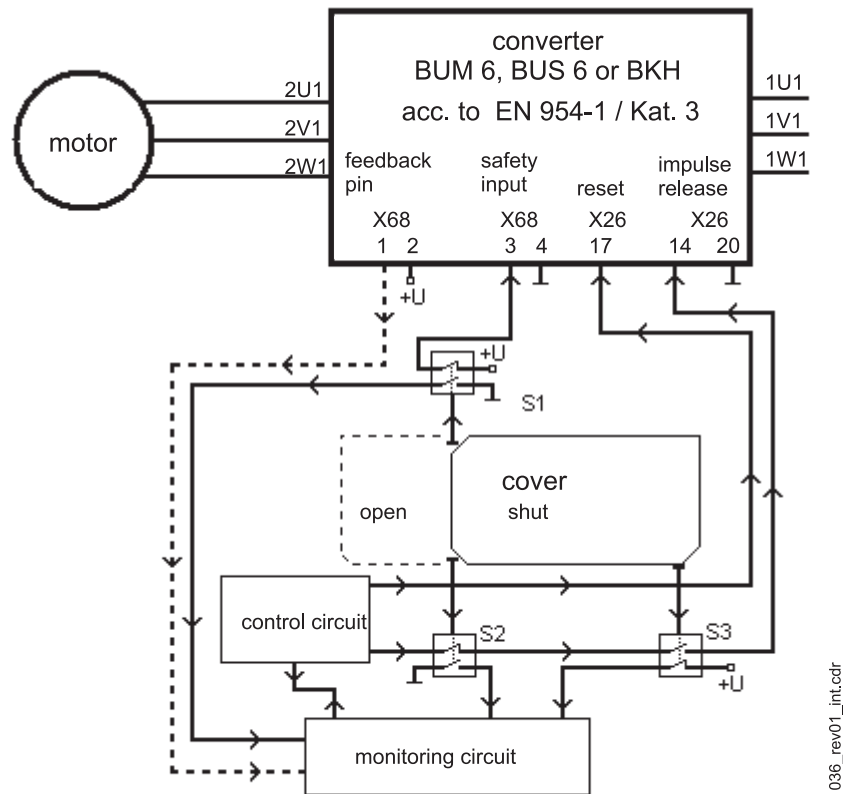

Figure 39: Application example for safe stop according to category 3 (EN 954-1)

The switching-off of the electrical drive motor operates dual-ported.

- S2 (NC) and S3 (NO) effectuate the pulse enable input of the converter by hardware (X26: 14). Only if S2 and S3 display a shut cover (and therewith a safe state) voltage is being applied to the pulse enable input of the converter.
- S1 (NC) has hardware effects on the safety relay of the converter. Only if S1 displays a closed cover (and therewith a safe state) there is voltage at the safety relay input (X68: 3) and this generates a torque at the shaft of the motor. The NO of S1 is connected with the monitoring circuit.
- The monitoring circuit, a fail-safe monitoring control of the category 3 (EN 954-1), checks on its own the directly connected switching contacts of the position switch S1 (NO), S2 (NO) and S3 (NC). If the cover is not completely closed or if there is a theoretical impossible condition of the limit switch contacts (for example S1 and S2 show a different switching condition or S2 and S3 show the same switching condition), then the control circuit will not get an enable signal from the monitoring circuit. A missing enable signal of the monitoring device leads to a direct switching off of the converter by means of the control circuit. If the monitoring circuit has recognized an error (for example different switch state of S1 and S2), this is displayed to the operator and a commissioning of the drive is not possible until the error has been repaired.

- The status signal contact of the safety relay (X68:1.2 NC) is able to be additionally evaluated by the monitoring circuit (but this is not imperative).
- The position switches, which are used, must unavoidable have actuated and mechanical connected contacts as well as a dual-port connection (NC/ NO). The mechanical operating at the safety device must take place unavoidable, that means tamper-resistant.

The connection cables between the safety relay input (X68: 3.4) and the control as well as between the pulse enable input at the converter (X26: 14) the controller must not be installed outside the control cabinet in a common cable channel.

E.5 Application example for machine of category 4

Additional procedures when configuring a machine make it possible with a converter of the category 3 (EN 954-1) at safety-relevant operations for the 'protection against unexpected starting' also category 4 for the complete drive.

A possibility is the usage of a contactor, with which the phases of the motor cable is short-circuited.

The diagram shows exemplary the usage and cabling of a Baumüller converter of the series BUM 6, BUS 6 or BKH of a machine tool, at which the safe removal of work pieces at opened cover according to category 4 (EN 954-1) is possible.

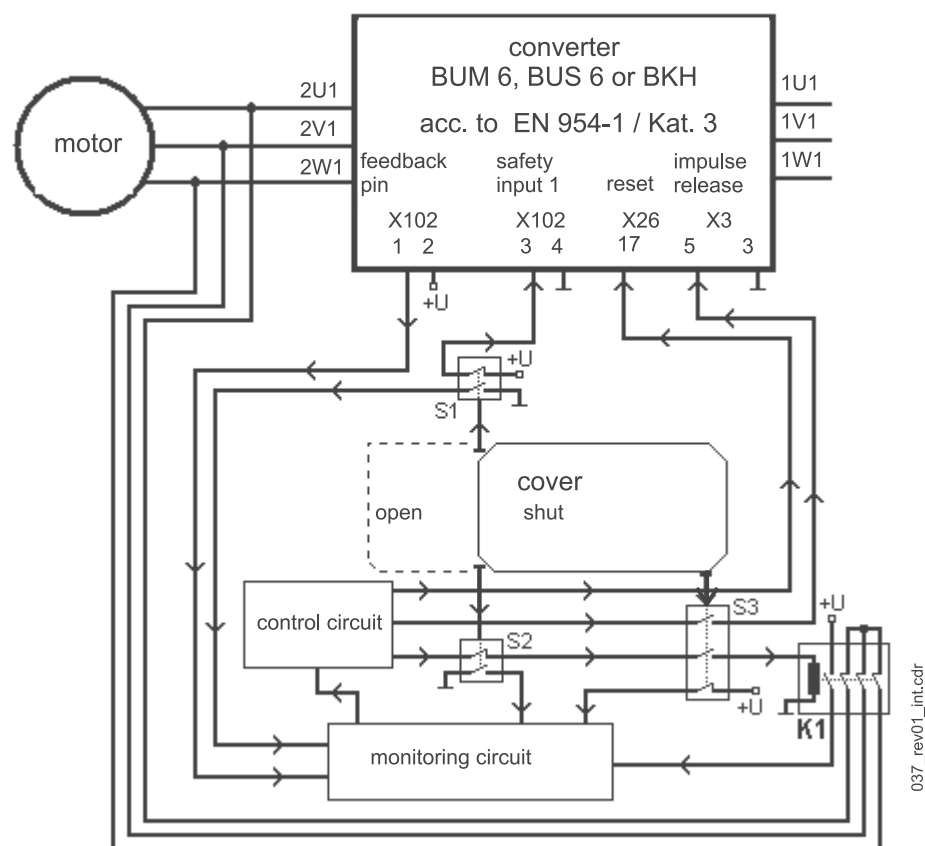

Figure 40: Application example for safe stop according to category 4 (EN 954-1)

The switching-off of the electrical drive motor operates three-ported.

- The contactor K1 with three NCs short-circuits the current to the motor in the enable state in all poles (closed-circuit current principle), so that no electrical energy of the converter arrives at the motor. S2 (NC) and S3 (NO) effectuate K1. Only if S2 and S3 display a closed cover (and therewith a safe state) K1 starts up and the short-circuit in the motor cable is reset. The status signal contact of K1 (NO) to the monitoring circuit is constructed with mechanical with the NC connected contacts. The selection of the contactor operates after its limiting short-time current load capability (10 ms). This must be greater than the nominal current of the used semiconductor fuses at the mains input of the converter.

- S1 (NC) has hardware effects on the safety relay of the converter. Only if S1 shows a closed cover (and therewith a safe state) there is voltage at the safety relay input (X68: 3) and makes a torque generation possible at the shaft of the motor. The NO of S1 is connected with the monitoring circuit.
- S3 (NO) has hardware effects on the pulse enable input of the converter (X26: 14). Only if S3 displays a closed cover (and therewith a safe state) voltage is applied to the pulse enable input of the converter.
- The monitoring circuit, a fail-safe monitoring control of the category 4 (EN 954-1), checks on its own the directly connected switch contacts of the position switches S1 (NO), S2 (NO), S3 (NC) and the status signal contacts of the safety relay (X68: 1.2 NC) as well as the contactor K1 (NO). If the cover is not completely closed or a theoretic impossible status of the limit switch contacts is present (for example S1 and S2 show a different switch status or S2 and S3 show the same switch status or the status signal contact of the safety relay is opened/closed, although the status signal contact of S1 is closed/opened), the control circuit receives no enable signal of the monitoring signal. A missing enable signal of the monitoring device leads to a direct switching off of the converter by means of the control circuit. If the monitoring circuit has recognized an error (for example different switch status of S1 and S2), this is displayed to the operator and the commissioning of the drive is not possible until the error has been repaired.
- The position switches, which are used, must unavoidable have actuated and mechanical connected contacts as well as a dual-port connection (NC/ NO). The mechanical operating at the safety device must take place unavoidable, that means tamper-resistant.

The connection cables between the contactor K1 and the control circuit as well as between the safety relay input at the converter (X68: 3.4) and the control circuit must not be run together in a cable channel outside the control cabinet.



NOTE

All information for the converter given in the manual, especially the chapters safety instructions, installation and commissioning, must absolutely be observed.

For the use and the installation of the safety devices the relevant legal and official regulations of the Safety Authorities and of the EU Directives for safety-engineering regulations at installations and machines (for example EN 60204-1, security of machines, electric equipment and EN 292-2, security of machines - general configuration guidelines).

E.6 Durability

The mechanical durability of the safety relay is at least 1×10^7 cycles of operation.



Table of figures

Cooling versions.....	24
Danger areas	25
Type key.....	26
Block diagram BUM 62 S/A/F	27
Block diagram BUM 62-70/200	28
Danger areas at mounting.....	29
Dimension diagram BUM 62 standard	31
Dimension diagram BUM62 through-hole version A	32
Dimension diagram BUM62 through-hole version F	32
Drill drawing BUM 62 standard	33
Drill drawing BUM 62 through-hole version A/F	34
Mounting instruction BUM62 S.....	36
Mounting instruction BUM62 through-hole version A/F.....	38
: Power connections BUM 62 S/A/F	47
: Power connections BUM 62-70/200.....	48
DC link connection	49
: Control connections X99A, X99B.....	51
: Ready-to-operate internal	51
: Control connection X99AB	53
: isolated optocoupler input	53
: Safety relay X68.....	55
: DC link quick discharge X90	56
Cabling proposal BUM62 S/A/F	58
Reducing effective aerial height	59
Reducing loop areas	59
Contact cables when exiting the housing.....	60
Cable screening at exiting housing	61
Screen on both sides	61
Connection diagram BUM62 S/A/F	64
Connection diagram BUM 62-70/200.....	65
Position of relay contacts and of LEDs	74
'Ready-to-operate (BB)	75
BB_Ext	83
Pre-warning/error	83
X68.....	83
Demounting scheme	92
Cooling air requirement.....	110
Sequence diagram of safety relay.....	118
Application example for safe stop according to category 3 (EN 954-1)	119
Application example for safe stop according to category 4 (EN 954-1)	121



Table of figures



Index

Numerics

73/23/EWG 101

A

Abbreviations 95
automatically restarting 79
automatically starting 79

B

Baumüller 11, 21
BB ext 76
BB INT 76

C

Cable
EMC instructions 57
Cables
laying 57
Cabling 58
Chopper resistor monitoring 79
Connection
DC link 111
Control cabinet
thickness of rear panel 30

D

DC link capacitor 111
DC link connection 66
Delete messages 77

E

EMC instructions 57
EMC-compatible installation 57
Environmental temperature 109

F

Filter mounting 62
Filtering 62
Fuses 98

G

Grounding 60

I

IT-mains 44

L

Leakage currents 62
Line up devices 49, 52
Lining up
of power modules 46, 63
Low Voltage Directive 101
Low-voltage supply 108

M

Mains failure monitoring 78
Mains voltage 108
Maximum temperature 81
Modification 9, 19
Monitoring 80
Mounting height 109

O

Output frequency 111
Overtemperature 81

P

Personnel
qualified 20
Phase failure monitoring 78
Power loss 111
Power modules
lining up 46, 63

Q

Qualified personnel 20

R

Ready-to-operate controller 75
Ready-to-operate external 76
Ready-to-operate internal 76
Ready-to-operate power unit 75
Ready-to-operate supply unit 75

S

Safe stop 115
Safety categories 117
Safety note
WARNING 53, 67
Safety notes
DANGER 46, 49, 50
Safety relay 117
is switched off 77
Screening 61
Skilled person 20
Start the drive 83
Supply unit
delete all messages 77
Supply voltage 108

T

Terms
definition 7
Thickness of rear panel
maximum 30

U

UL 508 C 44



Index

screwing	67
specifications	44
UL-Zertifizierung	105
unexpected starting	115

W

Warning	
reset message	78

be in motion

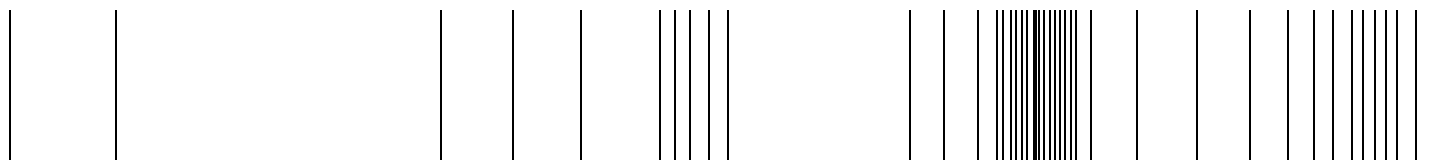

Baumüller Nürnberg GmbH Ostendstraße 80-90 90482 Nürnberg T: +49(0)911-5432-0 F: +49(0)911-5432-130 www.baumueller.de

All information given in this manual is customer information, subject to change without notice. We reserve the right to further develop and actualize our products continuously using our permanent revision service. Please notice, that specifications/data/information are current values according to the printing date. These statements are not legally binding according to the measurement, computation and calculations. Before you make any information given in this manual to the basis of your own calculations and/or applications, please make sure that you have the latest edition of the information in hand. No liability can be accepted concerning the correctness of the information.