



BAUMÜLLER

Instruction manual 3-AxisFlex

Short description:

The technology solution 3-AxisFlex is a machine template for applications that require movement in three-dimensional space, i.e. in X/Y/Z direction. G-code can be used to specify the coordinated motion control.

Version: 1.0 from 2021/07/01

Status: release

Autor: [VT]

1. Content

2. History	3
3. Introduction	3
4. Definitions	3
5. Requirements	4
5.1 Development system.....	4
5.2 Controller system.....	4
5.3 Hardware system.....	4
6. Safety related notes	5
7. System components	6
7.1 System structure.....	6
7.2 Input/output module.....	6
8. Functional overview	7
8.1 Navigation bar.....	8
8.1.1 Function keys.....	9
8.1.2 Time & Date.....	9
8.2 Status bar.....	10
8.2.1 User.....	10
8.2.2 Status.....	10
8.2.3 Position.....	11
8.2.4 G-Code.....	11
8.2.5 Communication status.....	11
8.3 Initialization.....	12
8.4 Home.....	13
8.5 Automatic.....	15
8.6 Manual.....	18
8.7 Editor.....	22
8.8 Settings.....	23
8.8.1 Overview.....	23
8.8.2 General.....	25
8.8.3 Interface.....	27
8.8.4 Language.....	28
8.8.5 User management.....	29
8.8.6 Homing.....	30
8.8.7 Kinematics.....	31
8.8.8 Dynamics.....	32
8.9 User login.....	33
8.10 Service.....	35
8.10.1 Overview.....	35
8.10.2 PLC inputs/outputs.....	37
8.10.3 Drive inputs/outputs.....	38
8.10.4 System.....	40
8.10.5 Monitoring.....	41
8.11 Alarms.....	42
8.12 Shutdown of the machine.....	44
8.13 Virtual Event Generator.....	45
9. Error list	46
10. List of illustrations	47

2. History

Version	Date	Name	Change
1.0	2021/07/01	VT	Initial Version

3. Introduction

This document provides an overview of the functionalities of the software template 3-AxisFlex version 2.3.0. The pre-configured system solution for multi-axis applications already includes all basic functions and can be easily adapted to the respective application.

The template includes two parts: the basic Coordinated Motion 3D-Axis library and the PLC and HMI templates, as well as a wizard-guided installation.

For better illustration, functions are partly shown and explained by using illustrations of the user interface. Technical information of the hardware can be found in the corresponding instruction manuals or parameter manuals on the [Baumüller Website](#) in the Service\Downloads section.

4. Definitions

Term	Definition
HW	Hardware
LOG	Logic
PII	Process image of the inputs
PIQ	Process image of the outputs
POU	Programming Organisation Unit
PLC	Programmable logic controller
TCP	Tool Center Point

5. Requirements

5.1 Development system

Description	Version
Microsoft Windows 10	ab V20H2
ProMaster Engineering Framework	ab V1.21.1.34
SCADA Editor	ab V7.02.00.20

5.2 Controller system

Description	Version
Baumüller PLCmc	ab Image V3.1.1.0

5.3 Hardware system

Beschreibung	Version
bmaXX5000	ab FW 1.15.04

6. Safety related notes

DANGER	
	<p>... indicates an imminently dangerous situation that will result in death or serious injury if not avoided.</p>

WARNING	
	<p>... warns of a potentially dangerous situation that can lead in death or serious injury if it is not avoided.</p>

ATTENTION	
	<p>... warns of a potentially dangerous situation that can lead to minor or slight injuries if it is not avoided.</p>

NOTICE	
	<p>... warns of a potentially dangerous situation that can lead in material damage if it is not avoided.</p>

Note!	
	<p>... points out useful tips and recommendations as well as information for efficient, trouble-free operation.</p>

7. System components

This chapter describes the system structure and the digital input and output module.

7.1 System structure

The following illustration shows a schematic system structure. In addition to the required components such as control, touch monitor, inverter, etc., an optional retrofittable I/O module is also shown.

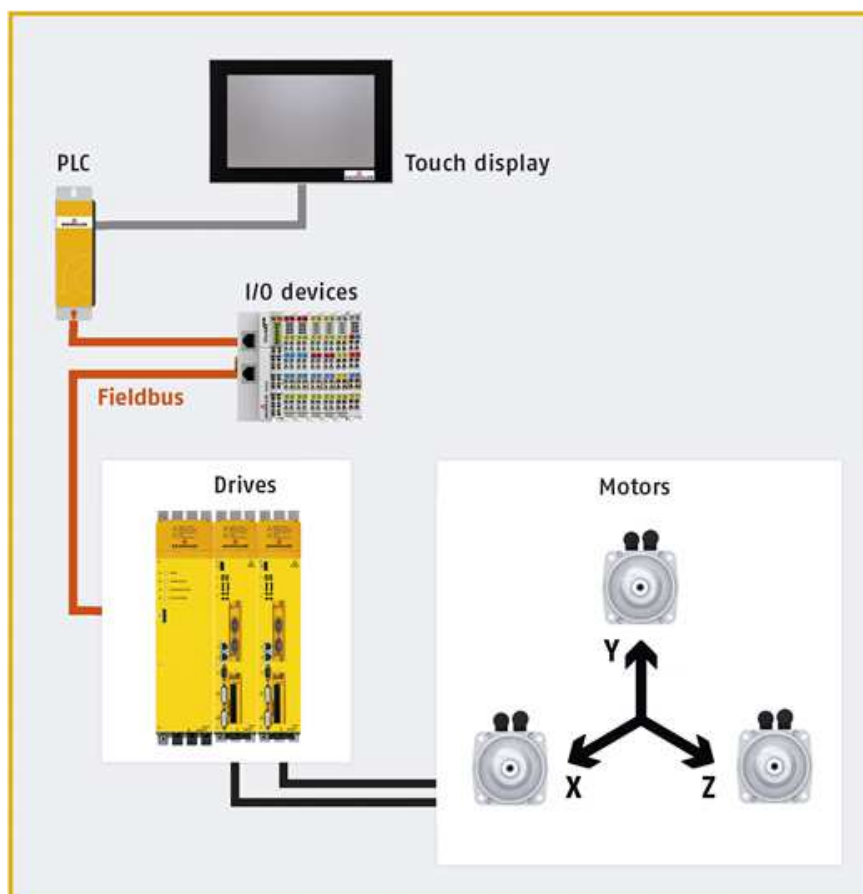

Illustration 1 – System structure

7.2 Input/output module

The I/O module is optional and not integrated in the standard configuration. The PLC inputs & PLC outputs are prepared exclusively in the service menu of the visualisation. In order for these to be used, corresponding changes to the software are required. This concerns the PLC software, Ethercat configuration and visualisation.

8. Functional overview

This chapter provides an overview of the available functions of the technology solution 3-AxisFlex. In general, all inputs for controlling and operating can be made via the user interface. In addition, some control commands can be made via an optionally connected I/O module.

The control concept is to be represented by the following simplified programme flow chart:

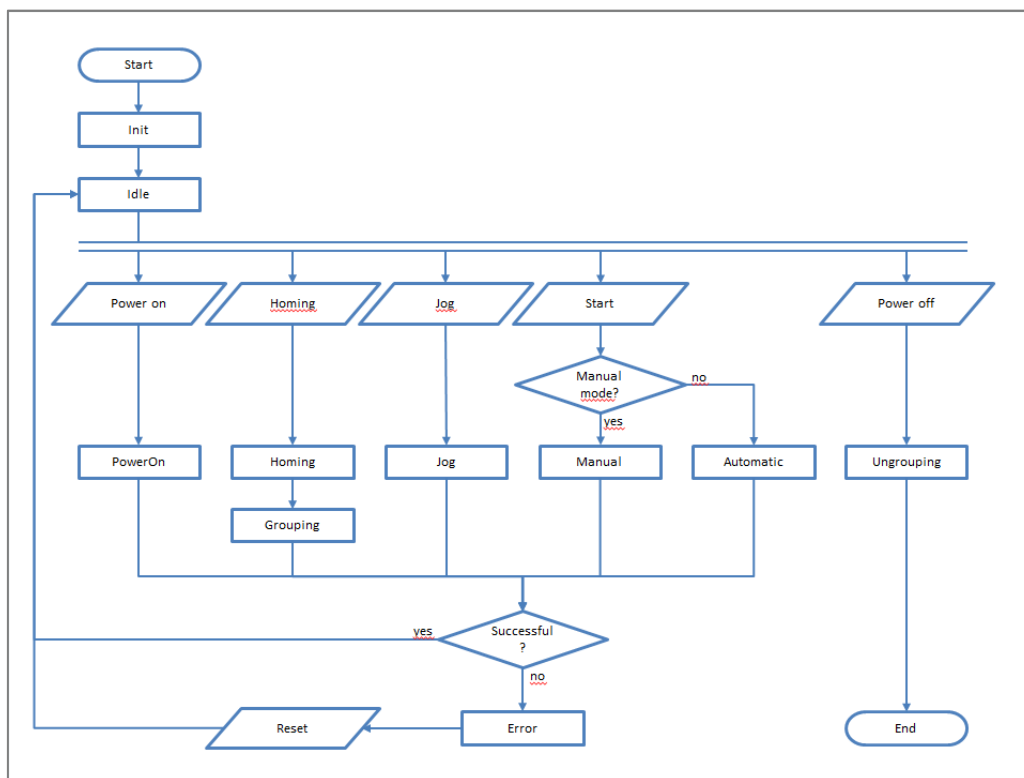

Illustration 2 - Programme flow chart (simplified)

Each page of the user interface is divided into the following three sections:

Navigation bar

Processing area

Status bar

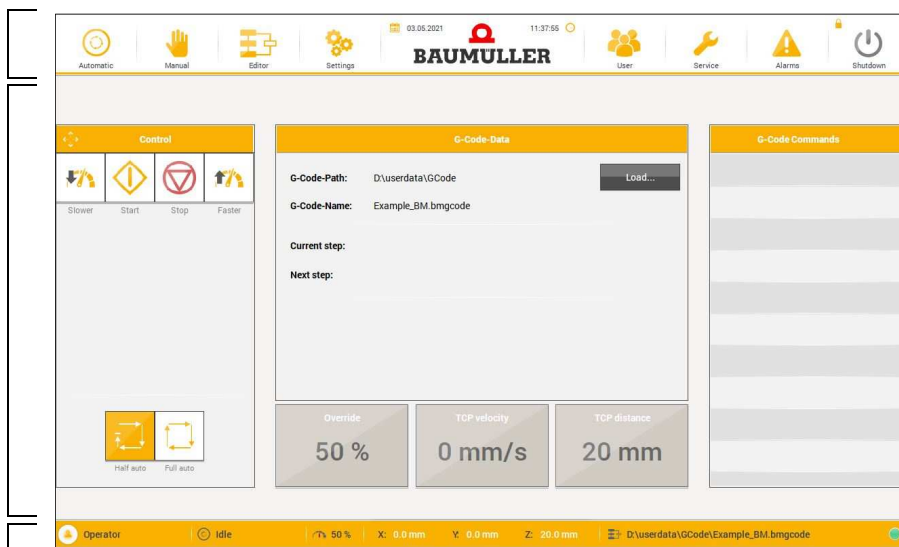

Note!



Some input fields can only be used from a higher user level. These are graphically marked with a lock. 









8.1 Navigation bar



Illustration 3 – Navigation bar

At the top of the user interface is the navigation bar, which is used to access the individual machine functions, e.g. automatic & manual mode. The content of this bar is always the same, regardless of the machine function called up.

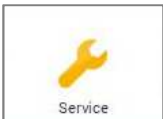
8.1.1 Function keys

Symbol	Description
 Automatic	Automatic mode: automatic processing of the movement commands stored in a G-code file.
 Manual	Manual operation: moving the individual machine axes by hand, moving to a target position in the working area.
 Editor	Editor: Open G-Code Editor to edit and save a G-code file
 Settings	Settings: switching machine functions on or off, entering machine settings, etc.
 Home	Home: starting/stopping and referencing the machine axes
 User	User: Login with the corresponding password to activate the different user levels.
 Service	Service: Diagnostic functions of the machine
 Alarms	Error management: Alarm history of the individual error messages with time stamp (Occurred, Resolved)
 Shutdown	Shutdown: permits switching off or restarting the machine (operable from user level 1).

8.1.2 Time & Date

Symbol	Description
	The current system time of the machine is displayed here. All time stamps in the system refer to this time, for example, entries in the error list, storage times, etc.

8.2 Status bar







Illustration 4 – Status bar

The status bar is located at the bottom of the user interface. This informs the operator about the current status of the machine. The most important information, such as the current user level, the current machine status, the actual position of the TCP in the working area and the G-code file currently loaded for automatic mode are displayed.







8.2.1 User

The following user levels are integrated:



Symbol	User	Level
	Operator	0
	Production Manager	1
	Setter	2
	Service	3
	Developer	4

8.2.2 Status

The following machine states are possible:

Symbol	Status	Description
	Init	Initialisation: Establishing the general operating condition, i.e. starting the user interface, the machine control/communication system, the drives and loading the necessary files.
	Idle	Idle: The machine is ready for operator input or to execute a move command. The TCP is at standstill.
	Homing	Referencing: The machine axes are referenced according to the set sequence.
	Manual	Manual mode: The individual machine axes are moved by hand or a target position in space is approached.
	Automatic	Automatic mode: Movement commands stored in a G-code file are executed.
	Error	Error: There are currently one or more error messages. Until the errors are cleared, the machine is not ready for operation in this state. The TCP is at a standstill.



8.2.3 Position

Symbol	Description
	Actual positions are not displayed before homing of all axes is completed.
	After the referencing procedure, the current position of the TCP (X/Y/Z) is displayed. The unit is [mm].

8.2.4 G-Code

Symbol	Description
	G-Code file currently loaded for automatic mode.

8.2.5 Communication status

Symbol	Description
	Status: Communication with the control unit is offline. (No data exchange)
	Status: Communication with the control unit is online (data exchange active).

Notiz!	
	Only when there is an active communication between the HMI and the PLC, the machine configuration is taken over and the required functionalities for starting or controlling are enabled. The data exchange starts automatically as soon as the HMI and PLC are ready for operation.

8.3 Initialization

After switching on the system, an initialisation page appears on the HMI. If the system start or initialization is completed successfully, the user is automatically forwarded.

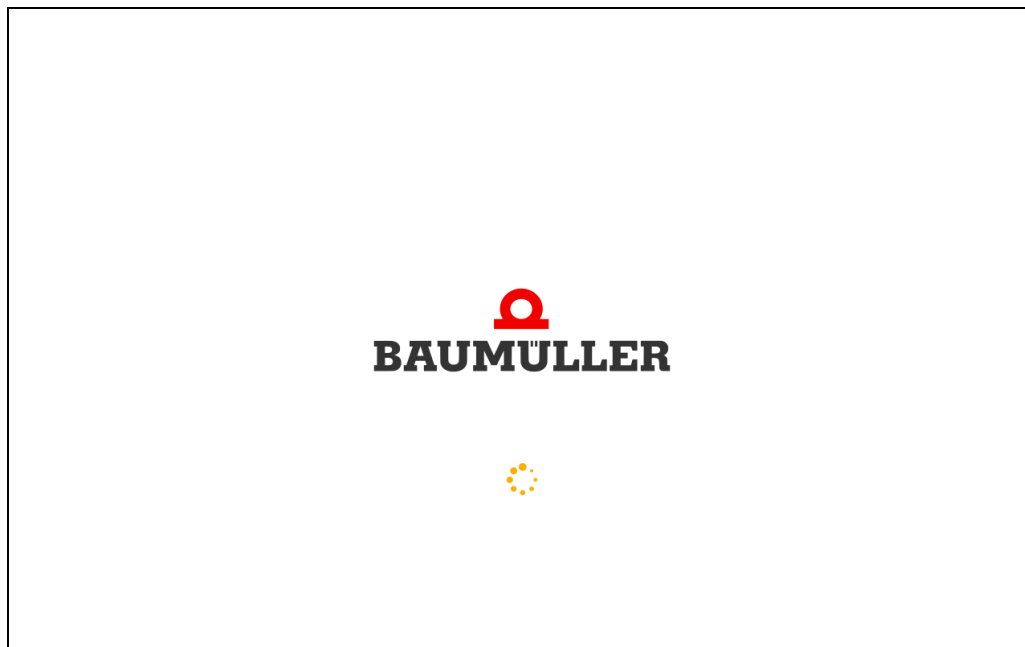
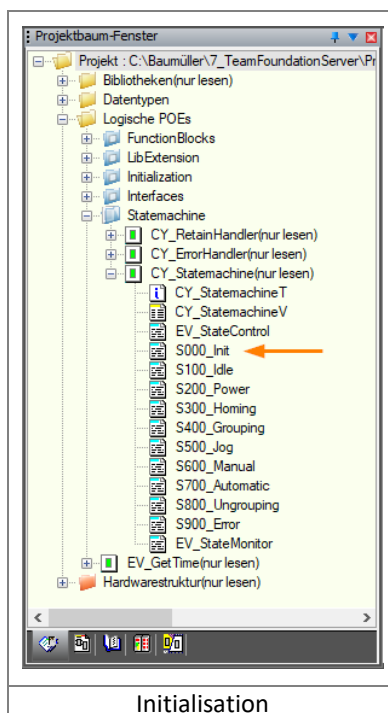

Illustration 5 – Initialization

During the initialization phase, various diagnostic functions are activated in the control and machine data (retain data) are loaded. (see state machine - section S000_Init)



8.4 Home

After successful initialization, the system automatically forwards the user to the home page. Here, the drives can be switched on/off and referenced.

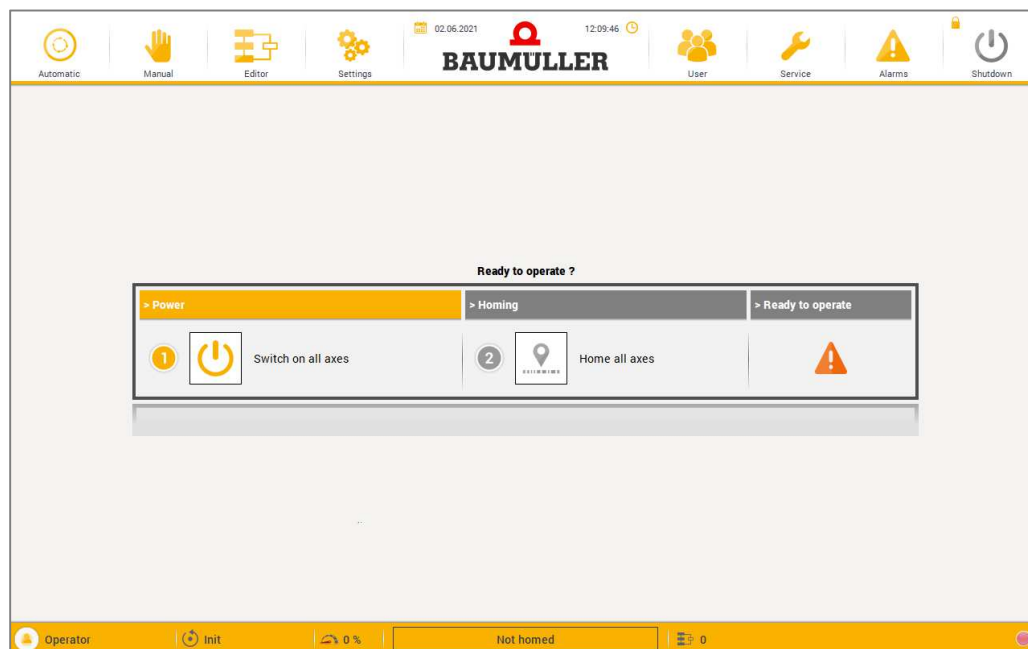





Illustration 6 – Home

Symbol	Description
	<p>Switch on: starts establishing general operational state, i.e. the drives are switched on. (drive active and holding brake open).</p> <p>Switch off: starts resetting the general operational state, i.e. the drives are switched off. (drive stopped and holding brake closed).</p>
	<p>Homing: starts the referencing of the machine axes according to the set sequence.</p>

WARNING	
	<p>The axes are enabled for operation after pressing the "Switch on" button, i.e. the inverter outputs power. It must be ensured that there are no persons in the working area!</p>

After establishing general operational state, the drives can be referenced. (see state machine - section S200_Power & S300_Homing).

Directly afterwards, the single axes are automatically added to an axis group and a kinematic transformation of the single axis coordinates is performed to describe the geometric relationship between the axis positions of the machine and the TCP in the coordinate system. (see State Machine - section S400_Grouping)

If the general operational state is reseted by switching off, the axis group is ungrouped and some diagnostic functions are deactivated. (see state machine - section S800_Ungrouping)

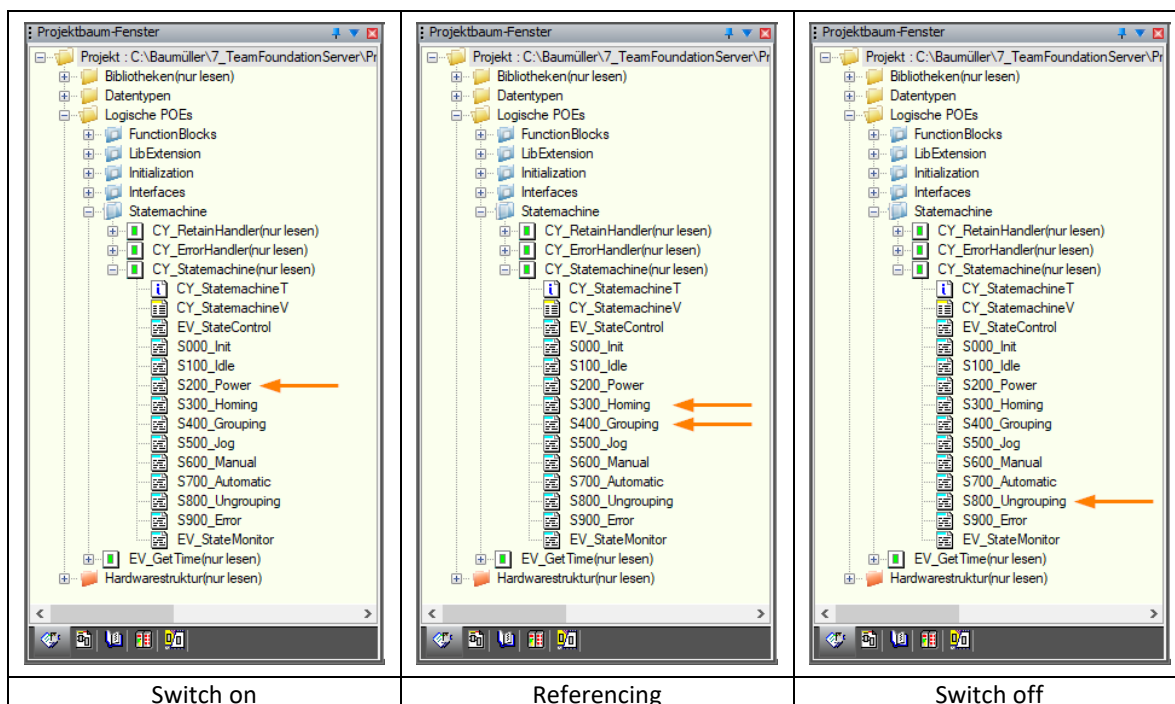

Note!







Only after a successful reference run are the axes in coordinated operation and all machine functions are enabled and the current position of the TCP (X/Y/Z) is displayed.

8.5 Automatic

In automatic mode, all drives are controlled together as a group and automatically by movement commands stored in a G-Code file. The velocity of the single axis depends on the [settings of the axis group dynamics \(TCP\)](#) and the set override factor. All characteristic values are maximum values and can vary depending on the given path movement.

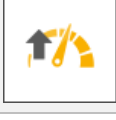

Illustration 7 – Automatic

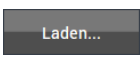
Symbol	Description
	Slower: Reduces the override factor for the path velocity in 10% steps to a minimum value of 0%. At the minimum, the TCP is at standstill.
	Start: Starts the automatic processing of the movement commands stored in a G-Code file.
	Stop: Stops the G-Code file from proceeding.
	Faster: Increases the override factor for the path velocity in 10% steps up to a maximum value of 100%. The maximum corresponds to the dynamic settings.
	Half Auto: The G-code file is processed once.
	Full Auto: The G-Code file is run periodically until a stop command is given.
	Load: Opens the file dialogue for loading a G-Code file.

WARNING	
	If the override factor is set to 0% while the machine status "Automatic" is active, the TCP is at standstill, but the axes are still enabled! No persons are allowed to enter the working area!

The Automatic mode uses the G-Code interpreter MC_MovePath to move the tool centre point (TCP) of the axis group on a path, in space from the starting position to the end position in the PCS coordinate system. (see state machine - section S700_Automatic)

The function block MC_MovePath is part of the Coordinated Motion library MOTION_COORD_40bdxx.

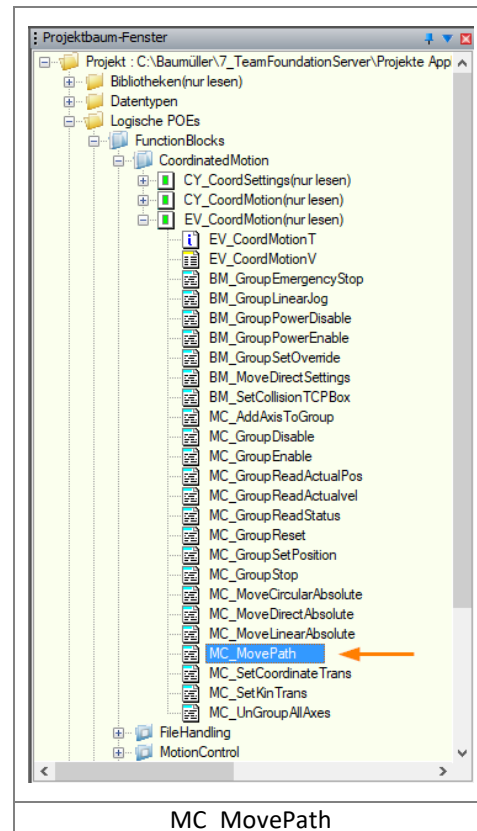
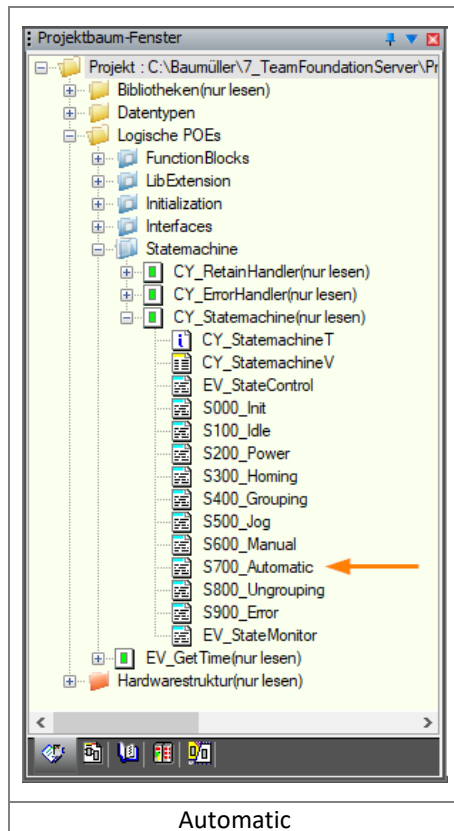

8.6 Manual

In the manual operating mode, all axis can be moved individually via jog mode, as well as together as a group to a target position in the space. The velocity of the single axis motors depends on the settings of the axis group dynamics (TCP); single axis dynamics and the override factor. All characteristic values are maximum values and can vary depending on the given path movement.

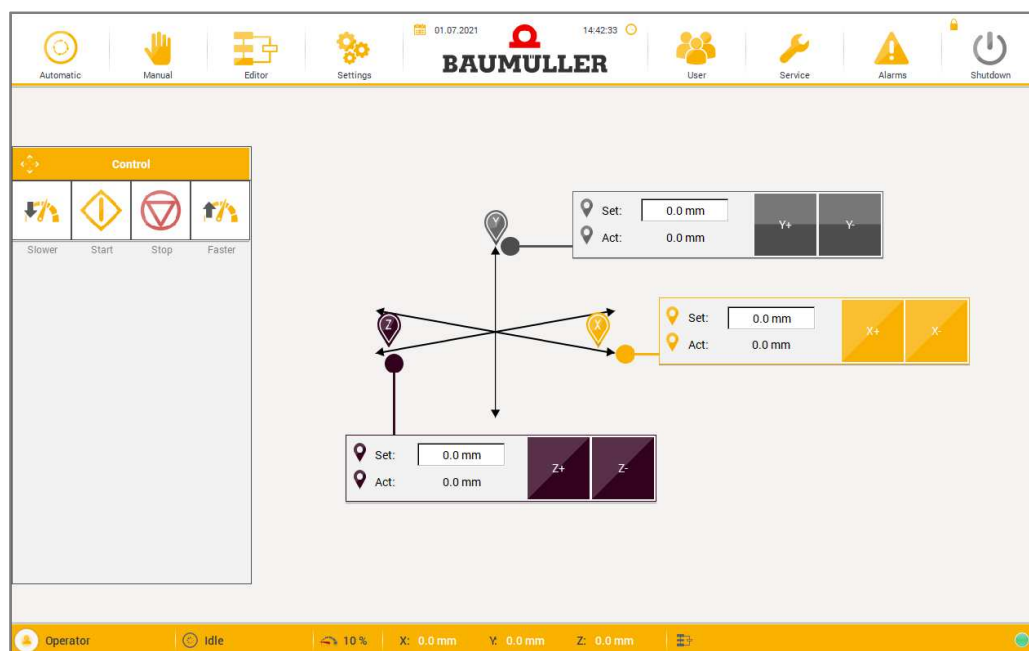

Illustration 8 – Manual (referenced)

Before all axes have completed homing, it is not possible to enter a target position or coordinated movement of the axes. However, jogging of the individual axes is possible directly after switching on, the axes are then moved by single motion. As long as referencing is still pending, the motor angle in [°] is displayed as the actual position.

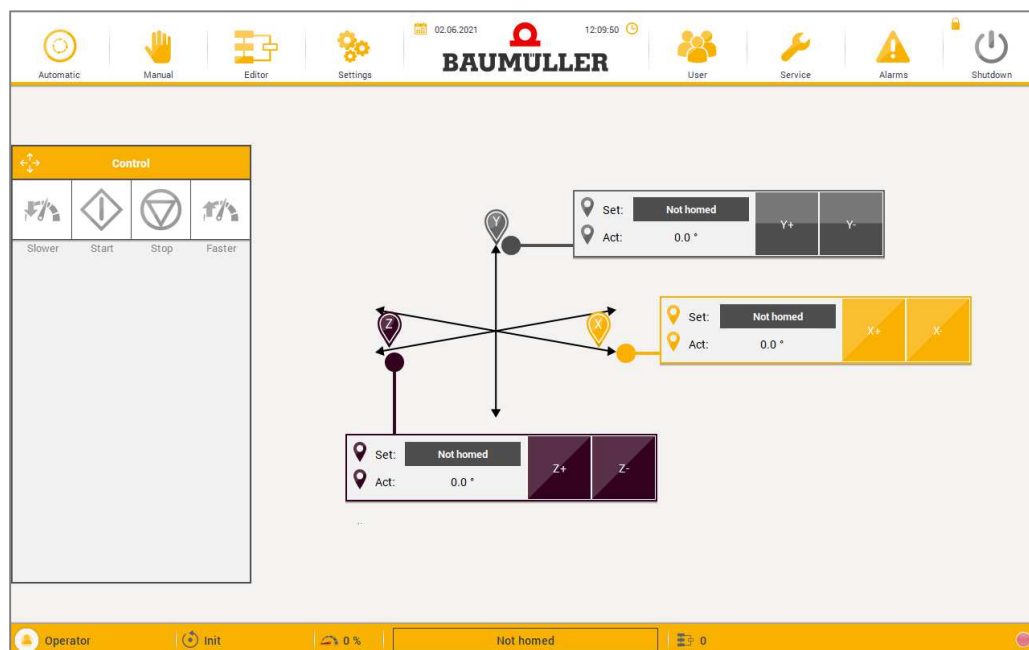



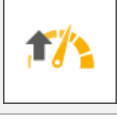



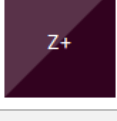
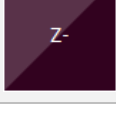

Illustration 9 – Manual (not referenced)

Symbol	Description
	Slower: Reduces the override factor for the path velocity in 10% steps to a minimum value of 0%. At the minimum, the TCP stands still.
	Start: Starts the automatic movement to a predefined target position in the space.
	Stop: Stops moving to the predefined target positions in space.
	Faster: Increases the override factor for the path velocity in 10% steps up to a maximum value of 100%. The maximum corresponds to the dynamic settings.
	X+: jogging the X-axis in positive direction
	X-: jogging the X-axis in negative direction
	Y+: jogging the Y-axis in positive direction
	Y-: jogging the Y-axis in negative direction
	Z+: jogging the Z-axis in positive direction
	Z-: jogging the Z-axis in negative direction

WARNING

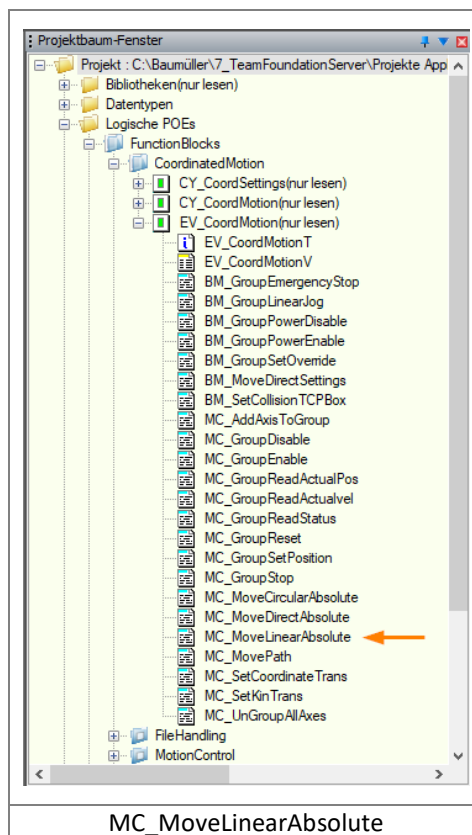
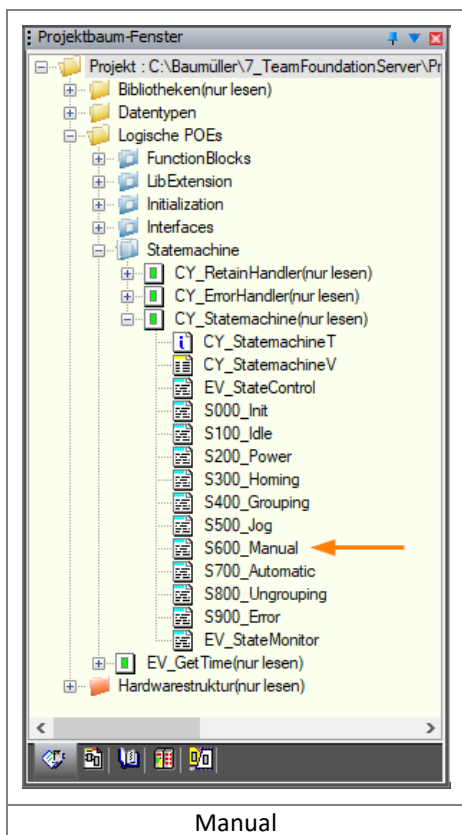

If the override factor is set to 0% while the machine status "Manual" is active, the TCP is at standstill, but the axes are still enabled! No persons are allowed to enter the working area!

In manual mode, the Coordinated Motion function block MC_MoveLinearAbsolut is used to move the TCP of the axis group on a straight-line path in space from the starting position to the absolutely given target position. (see state machine - section S600_Manual)

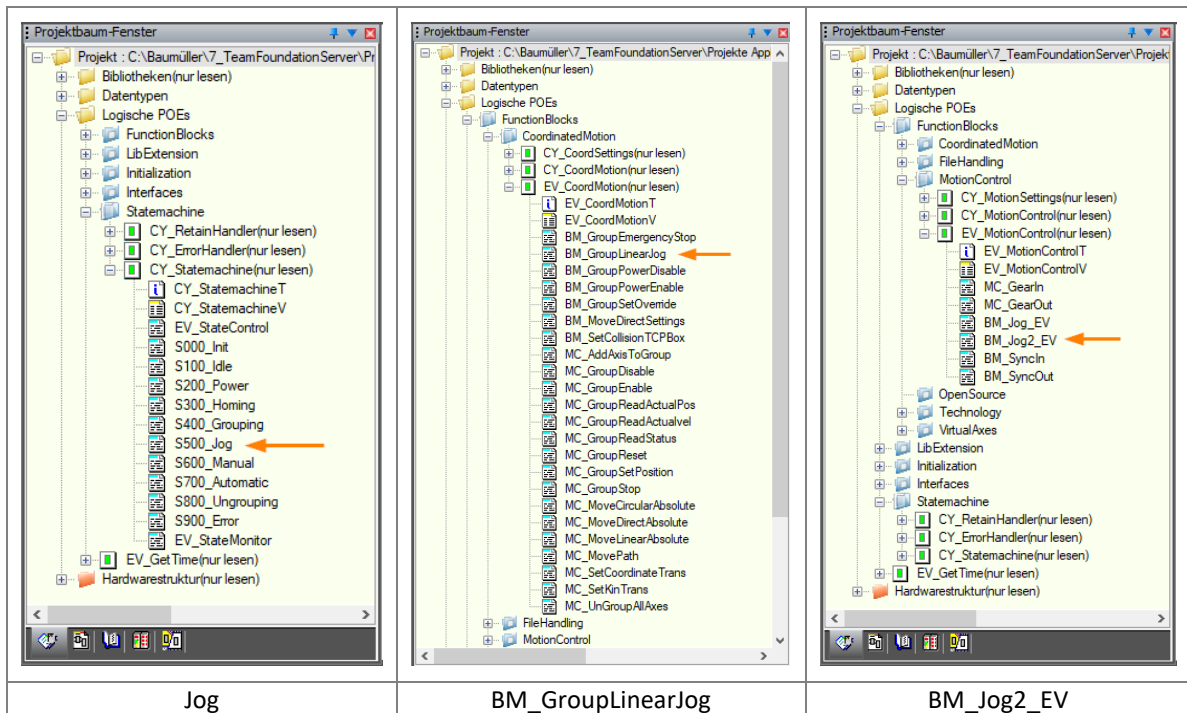

In manual mode, the Coordinated Motion function block **BM_GroupLinearJog** is used to move the TCP on a linear path in jog mode. (see state machine - section S500_Jog)

If referencing has not been carried out yet, the motion control function block **BM_Jog2_EV** is used for jog mode in order to move the individual axes by synchronous setpoint value.



8.7 Editor

The free text editor "Notepad++" is available to the machine operator for editing a G-code file.

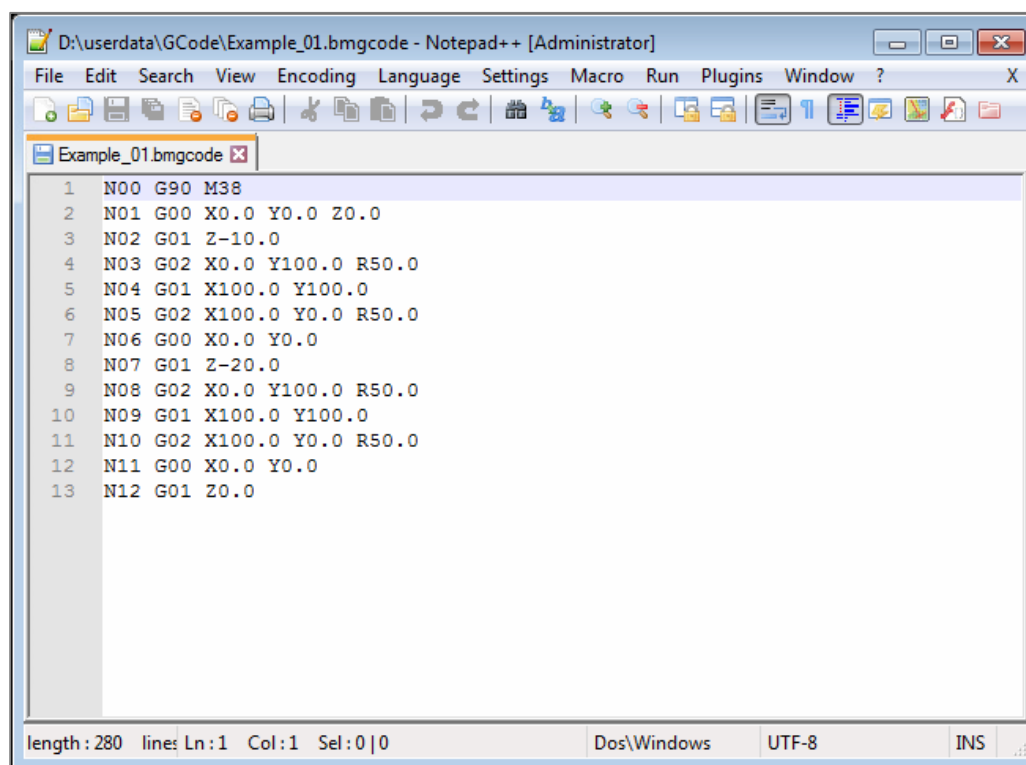

The screenshot shows a Notepad++ window titled "D:\userdata\GCode\Example_01.bmgcode - Notepad++ [Administrator]". The menu bar includes File, Edit, Search, View, Encoding, Language, Settings, Macro, Run, Plugins, Window, and ?. The toolbar contains various icons for file operations and editing. The main text area displays the following G-code:



```

1 N00 G90 M38
2 N01 G00 X0.0 Y0.0 Z0.0
3 N02 G01 Z-10.0
4 N03 G02 X0.0 Y100.0 R50.0
5 N04 G01 X100.0 Y100.0
6 N05 G02 X100.0 Y0.0 R50.0
7 N06 G00 X0.0 Y0.0
8 N07 G01 Z-20.0
9 N08 G02 X0.0 Y100.0 R50.0
10 N09 G01 X100.0 Y100.0
11 N10 G02 X100.0 Y0.0 R50.0
12 N11 G00 X0.0 Y0.0
13 N12 G01 Z0.0
  
```

The status bar at the bottom indicates "length: 280 lines: Ln: 1 Col: 1 Sel: 0|0", "Dos\Windows" encoding, "UTF-8" character set, and "INS" input mode.

Illustration 10 – Notepad++ G-Code Editor

8.8 Settings

Notiz!	
	<p>Some input fields can only be used from a higher user level. These are graphically marked with a lock. </p>



8.8.1 Overview

The "Settings" section is separated into different areas within which the operator can set parameters. The available areas are:

Settings	
General	Homing
Interface	Kinematics
Language	Dynamics
User management	

Illustration 11 – Overview Settings

- **General:** Activate user log
- **Referencing:** Order of axis referencing / reset referencing
- **Interface:** Deactivate mouse indicator
- **Kinematic:** Gear ratio, axis lengths
- **Language:** Set the language of the user interface
- **Dynamic:** Velocities for the different operating modes
- **User management:** Information about the individual levels

Symbol	Description
	Save: Starts the saving process for the settings
	Saving active: The saving process is active
	Saving done: Settings has been saved successfully

For saving the machine settings (retain data), the firmware function blocks for opening, reading, writing and closing files are used. (see CY_RetainHandler)

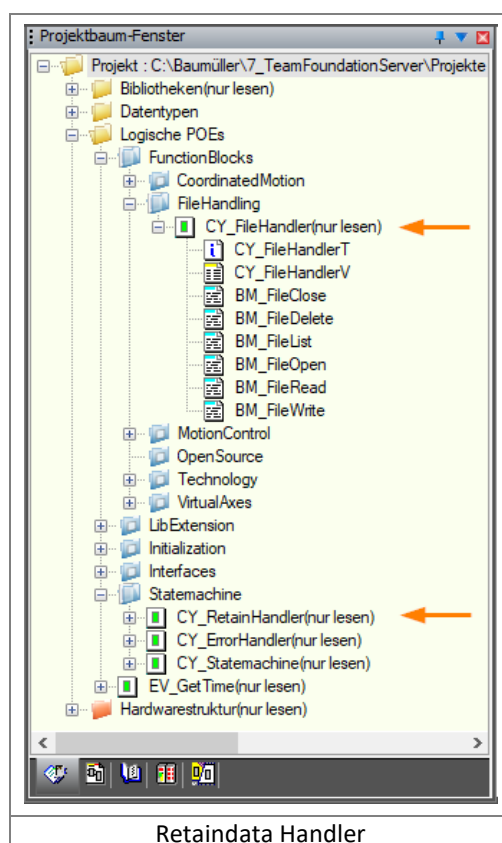

8.8.2 General



Illustration 12 – Settings General

- **Virtual axes:** All movements can also be carried out with virtual axes instead of the real ones. If the activation is made during an axis movement, the changeover is made as soon as the machine has changed to the Idle status. This option is available from user level 4.
- **User log:** For diagnostic purposes, it is possible to write the sequence of the PLC internal step chain in a log file on the PCC (PLC.log). This option is available from user level 3.
- **Directory path:** Displays the location and name of the machine settings file. The file path cannot be changed.

NOTICE	
	<p>Each time you switch between real and virtual axes, the referencing of the axes is removed! As a result, it is always necessary to repeat the procedure for switching on and referencing.</p>

The Coordinated Motion assistant function block EV_VirtualCoordAxis is used for the Virtual Axes option. Activating this function shifts the axis reference from the real axes to virtual axes for all function blocks. This is particularly helpful in the software development phase, as function tests can be carried out and dangerous situations caused by uncontrolled axis movements can be avoided.

The TB_StateMonitor_IAX technology block is used for the user log option. This module can be used for detailed diagnosis of the state machine. Each state change is entered in a state trace and saved with additional information in a log file on the PCC.

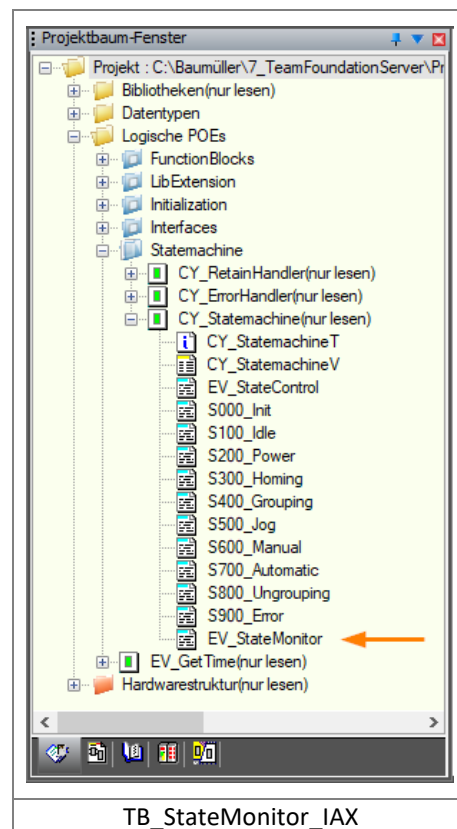
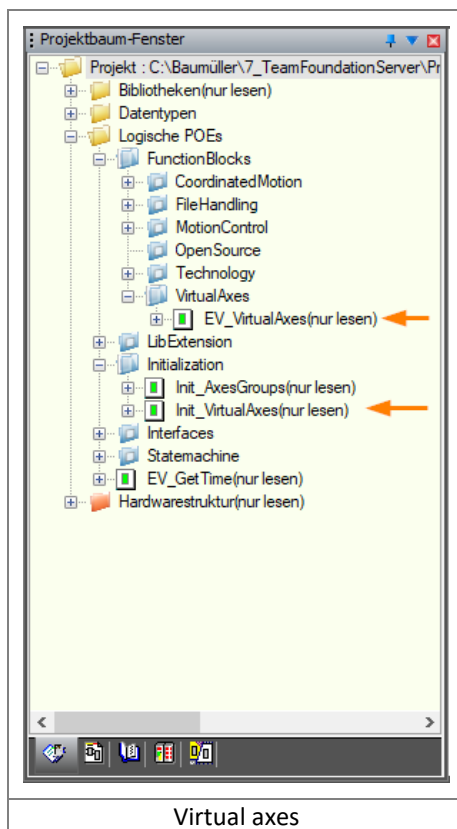

The extended user logging can be viewed directly in the command line window of the PCC, provided that the debugging option of the PLC is activated.

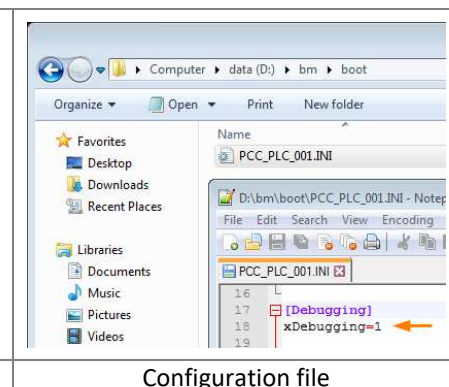
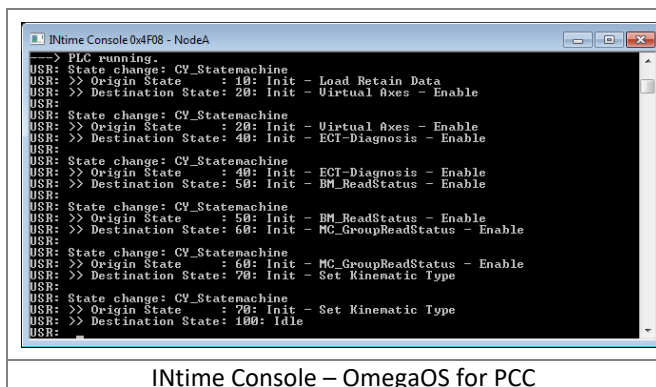

8.8.3 Interface

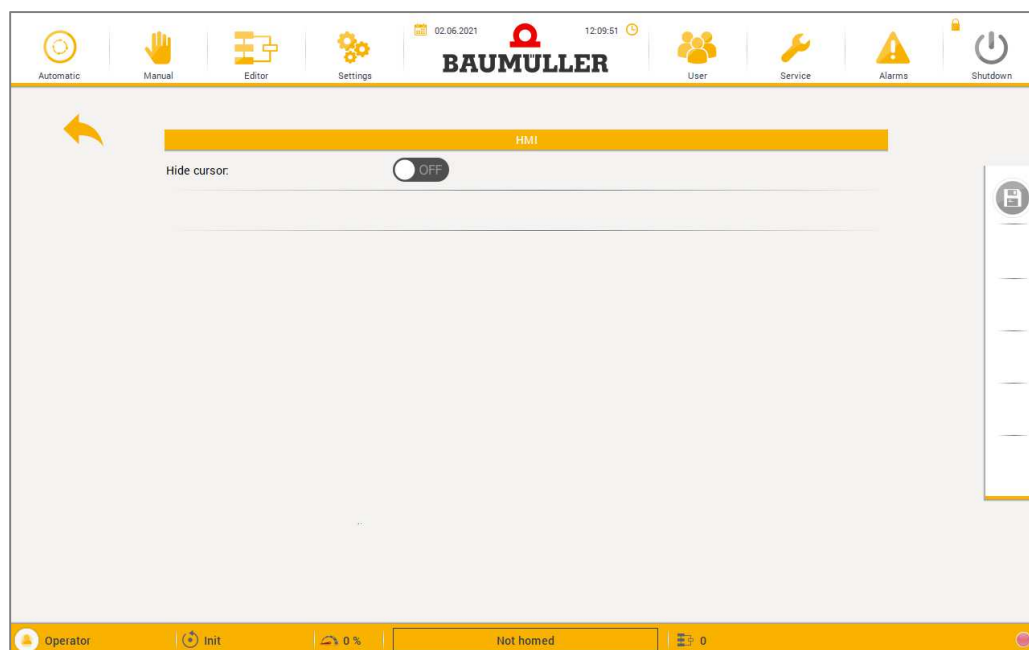
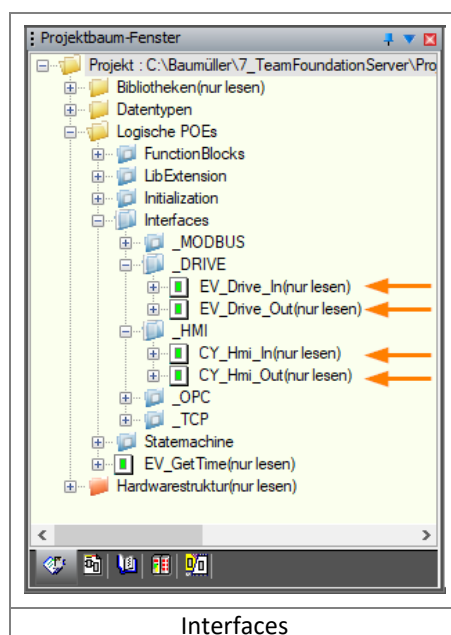

Illustration 13 – Settings Interface

- **Display cursor:** By default, the mouse pointer is hidden. However, it can be displayed for training or remote maintenance purposes, for example.

The application interfaces to the drive and to the visualisation (HMI) can be found in the control system interfaces area. In the POU's with the suffix "_In", the PI is created and the data is copied into the controller-internal data structure "Iface" for further processing. In the POU's with the suffix "_Out", the required data is read from the "Iface" data structure, copied into the PIQ and forwarded to the corresponding PLC periphery.



8.8.4 Language



Illustration 14 – Settings Language

- By clicking on the desired country flag, the language is switched immediately.

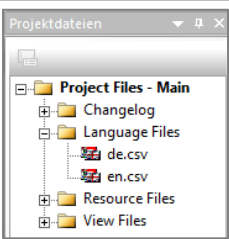
Symbol	Description
	<p>All texts in the visualisation can be translated via the language file. This includes button names, error messages, information texts, etc. A separate language file is required for each language.</p>

8.8.5 User management

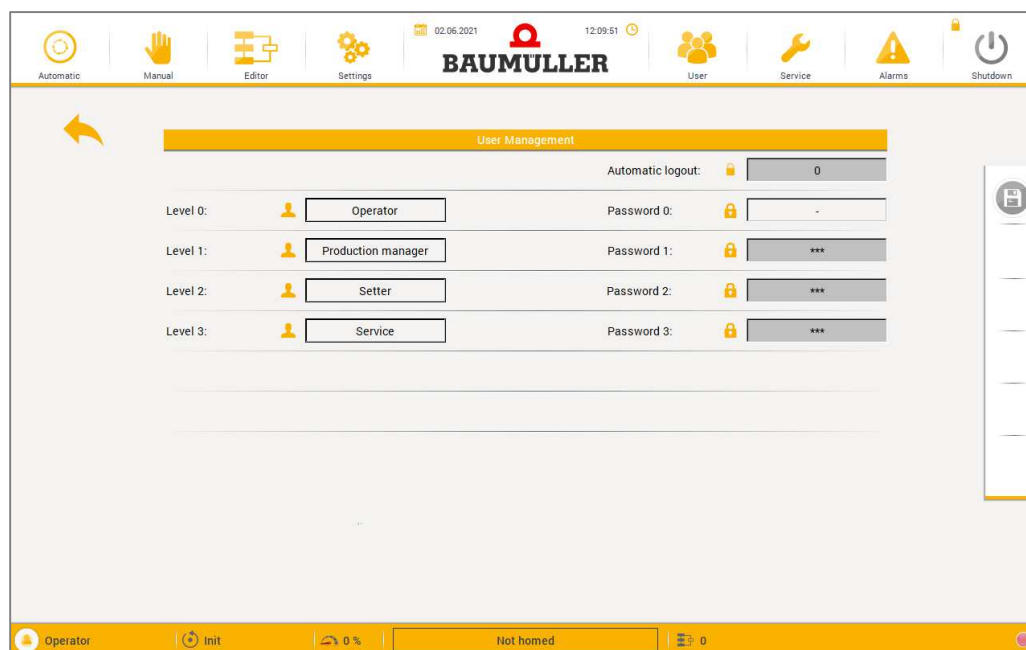

Illustration 15 – Settings User management

- **Log off automatically:** an inactive user is automatically logged off after the set time has elapsed. If the input value is shorter than the minimum value of 10s, the PLC automatically enters the default value of 60s. A change is possible from user level 2.
- **User:** In the visualisation, certain areas or operating options are protected by a user level. The user levels and corresponding passwords can be read in clear text, but not changed, depending on the current user. The user levels operator, production manager, adjuster, service and developer are available. Information about changing the passwords can be found in the chapter "[User Login](#)".

8.8.6 Homing

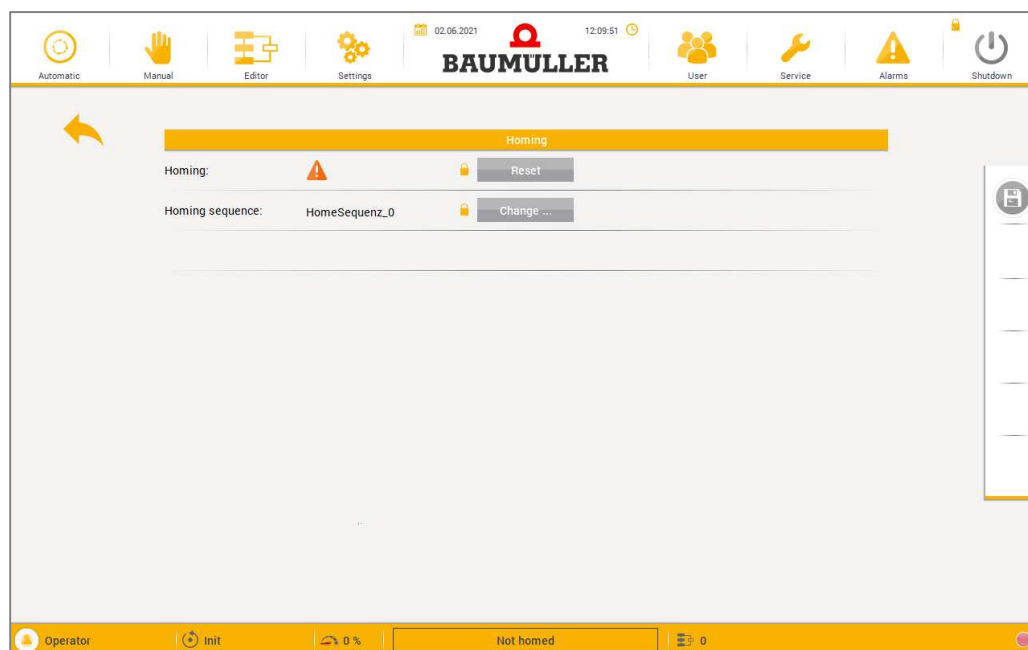

Illustration 16 – Settings Homing

- **Reset:** A successful referencing of the machine is indicated by a tick. ✓ If necessary, the referencing of the machine can be reset. ⚠ This function is available from user level 2.
- **Change...:** Here you can set the order in which the machine axes are to be referenced. For example, first the Y-axis, then the X-axis and then the Z-axis. This function is available from user level 2.

8.8.7 Kinematics

The basic mechanical data is set in the "Kinematics" section. This includes the mechanical scaling and gear/belt ratios. The value entry is possible from user level 2.

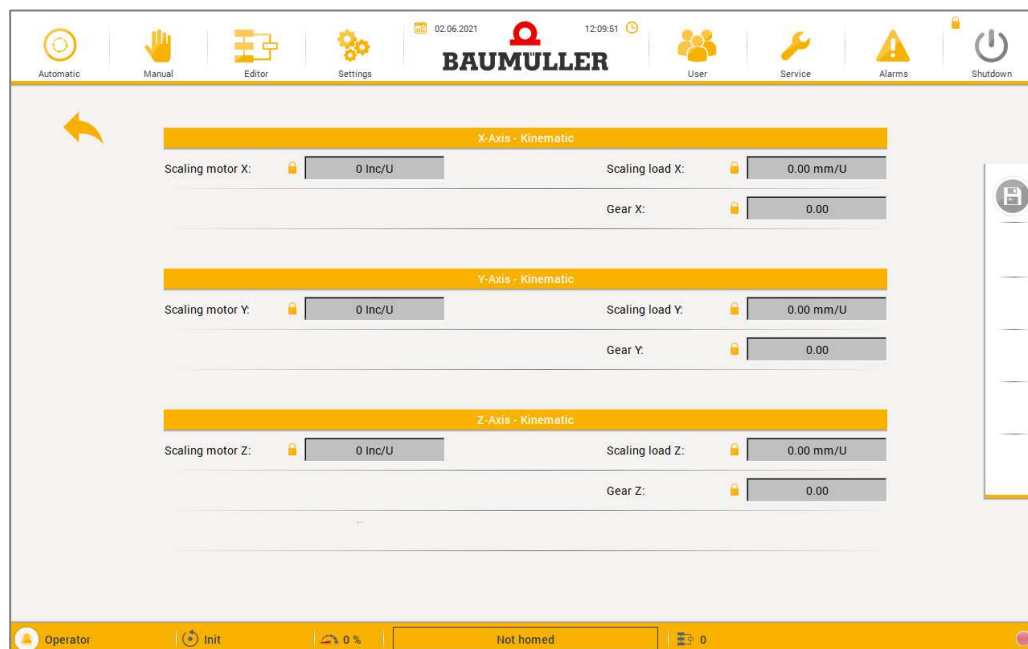



Illustration 17 – Settings Kinematic

- **Scaling motor:** Specifies the encoder resolution for one revolution.
- **Scaling load:** Specifies the mechanical resolution per motor revolution. (Gearbox output)
- **Gearbox:** Specifies the gear ratio.

NOTICE	
	<p>Missing or incorrect entry of the basic mechanical data can lead to material damage to the machine.</p>

8.8.8 Dynamics

In the "Dynamics" section, the characteristic values for the driving movements can be set.

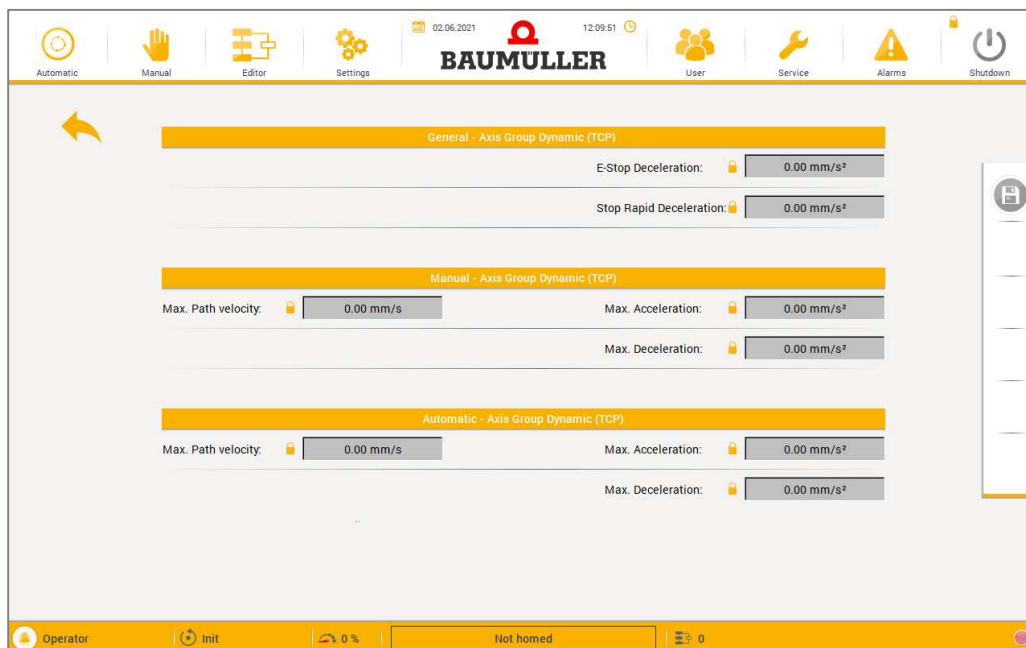

Illustration 18 – Settings Axis group dynamics

- **Axis groups dynamics:** Maximum permitted values for the speed, acceleration and deceleration of the TCP. The value input is possible from user level 2.



Illustration 19 – Settings single axes dynamics

- **Individual axes dynamics:** Maximum permitted values for the speed, acceleration and deceleration of the single machine axes. Value entry is possible from user level 2.

8.9 User login

In the "User login" section, the login is done by password.

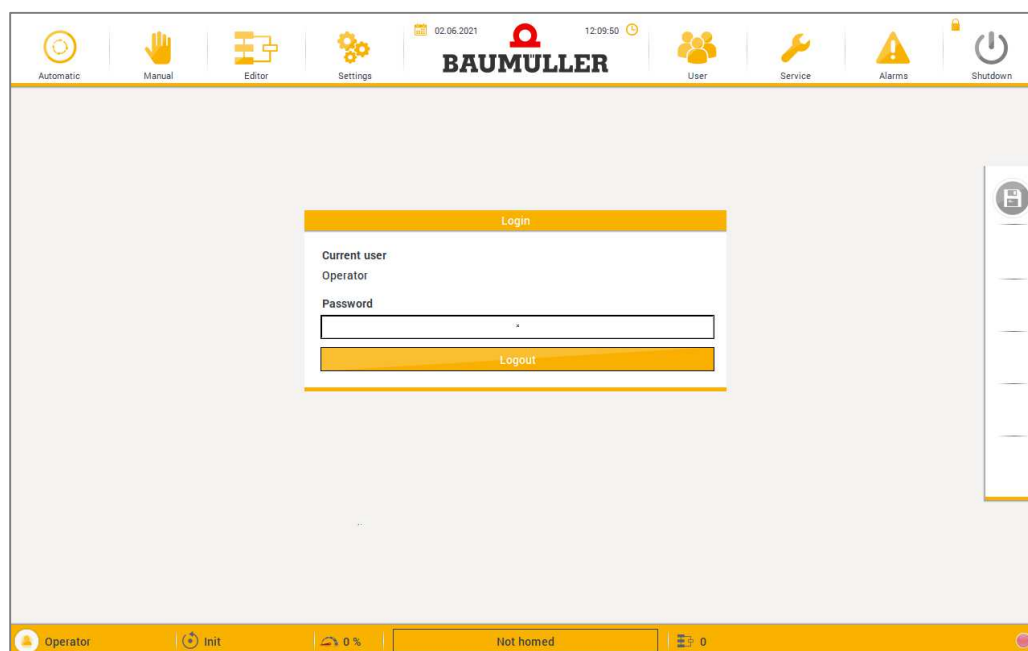





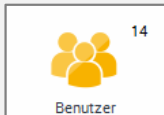

Illustration 20 – User login

- **User:** The following user levels are available:

Symbol	User	Level	Password
	Operator	0	-
	Production manager	1	1
	Setter	2	2
	Service	3	service
	Developer	4	develop

- **Inactivity timer:** If a user is logged in, a timer is displayed.

Symbol	Description
	In case of inactivity, the timer is incremented and when the time value for "Automatic logout" is exceeded, the user will be logged out.

Changing individual passwords is only possible by making the appropriate adjustments and re-transferring the HMI project. To do this, the macro for the user login must be opened in the Scada Editor in the User\Login.teq area.

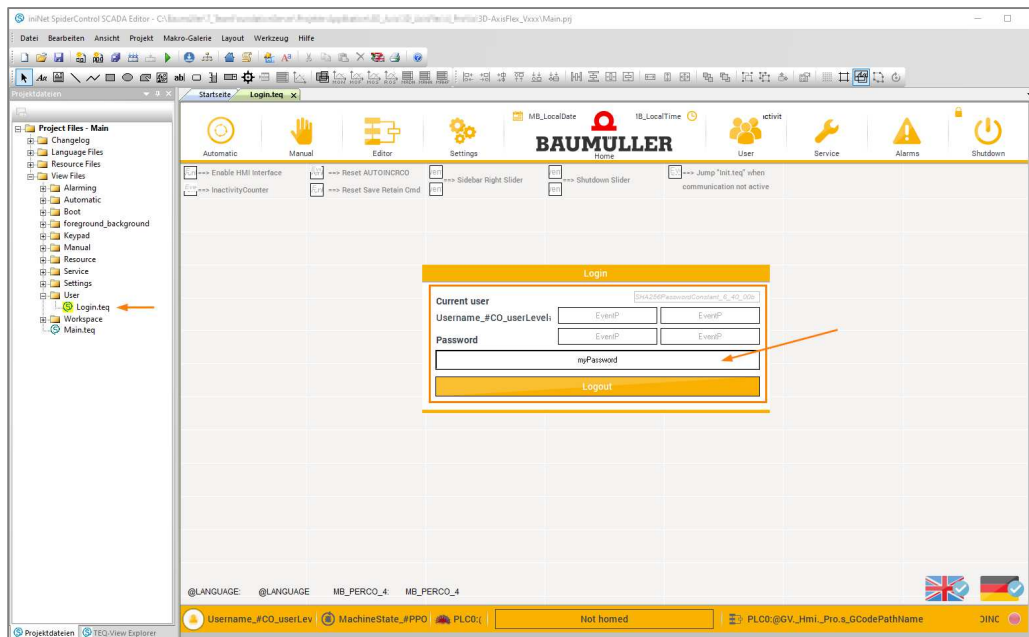
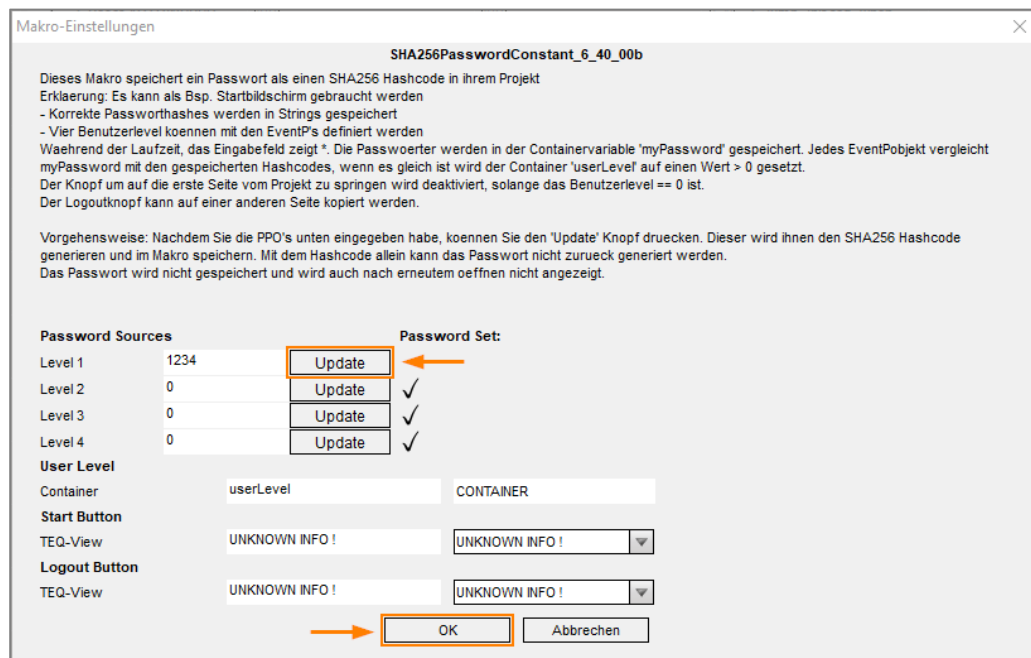



Illustration 21 – User login (HMI-Project)

The new password for the desired user level is then entered in the macro dialogue and accepted by pressing the "Update" button!



8.10 Service

In case of need, a wide range of functions are available to diagnose the machine in detail.

Note!	
	<p>Some input fields are only visible and operable from a higher user level.</p>

8.10.1 Overview

The "Service" section is divided into different areas, these are:

Service	
PLC Inputs	PLC Outputs
Drive Inputs	Drive Outputs
System	Monitoring

Illustration 22 – Overview Service

- **PLC inputs:** current state of the digital inputs (optional I/O module)
- **PLC outputs:** current state of the digital outputs (optional I/O module)
- **Drive inputs:** current state of the digital inputs on the drive
- **Drive outputs:** current state of the digital outputs on the drive
- **System:** summary of general information, e.g. software versions etc.
- **Monitoring:** trend display for drive position/speed

The basic signal processing of the PLC is shown below. First, the process image of the inputs (PII) is processed by the microprocessor and then the process image of the outputs (PIQ) is forwarded to the periphery of the PLC.

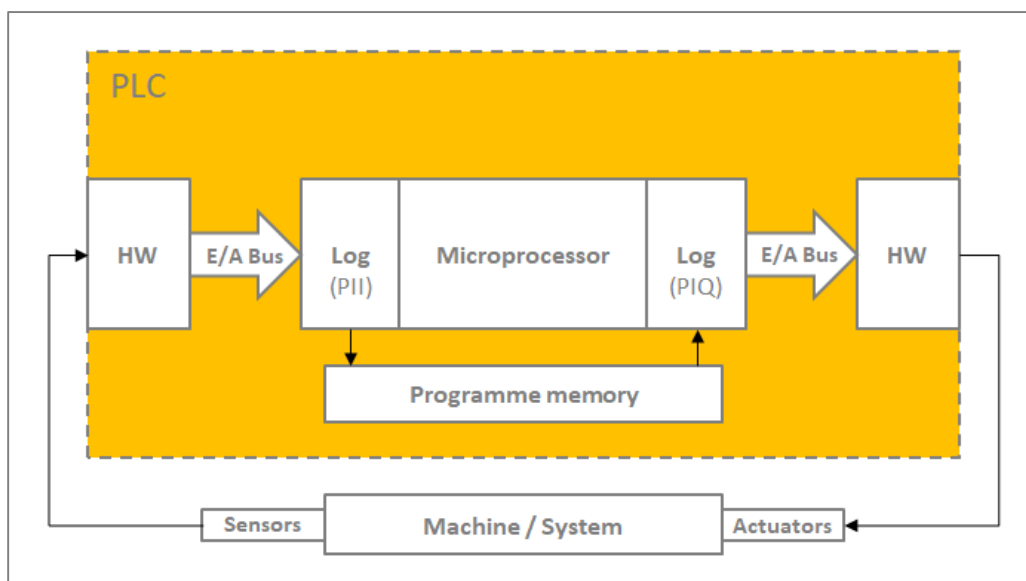

In the following subcategories of the service area, these symbols visualize the signal processing of the hardware logic level or the status of the digital inputs & outputs.

Symbol	Description
>>	Input: The HW logic level is transferred directly to the PII of the PLC. Output: The PIQ of the PLC is written directly to the HW output.
×	Input: The HW logic level is not transferred to the PII of the PLC. Output: The PIQ of the PLC is not written to the HW output
●	Status: The logic level is LOW
●	Status: The logic level is HIGH

8.10.2 PLC inputs/outputs

All digital inputs and outputs of the optional I/O module are visualised on the user interface.

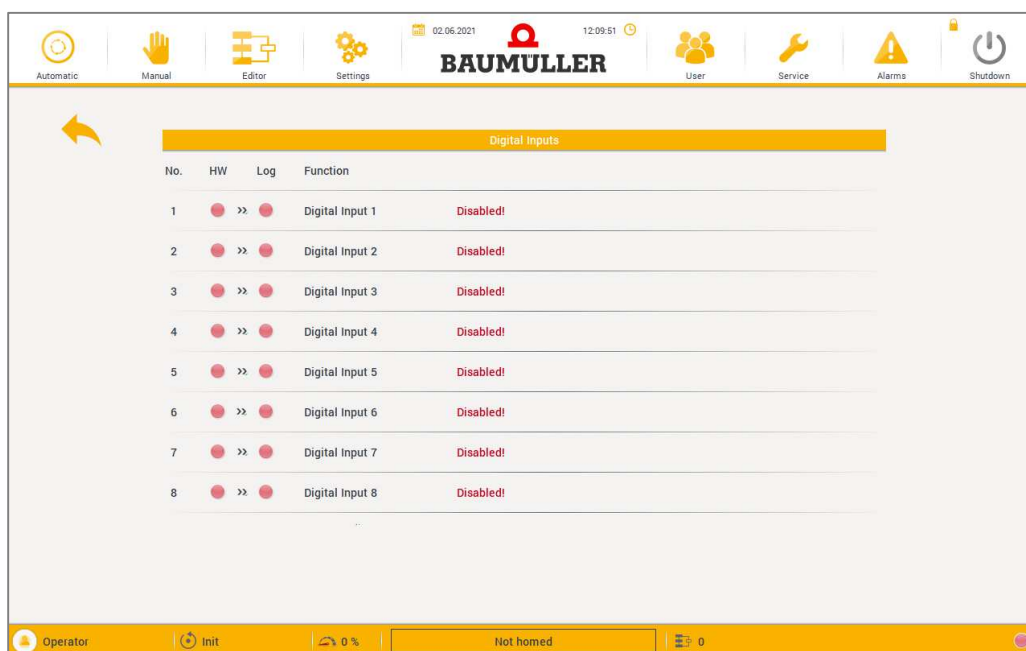

No.	HW	Log	Function	Status
1	●	●	Digital Input 1	Disabled!
2	●	●	Digital Input 2	Disabled!
3	●	●	Digital Input 3	Disabled!
4	●	●	Digital Input 4	Disabled!
5	●	●	Digital Input 5	Disabled!
6	●	●	Digital Input 6	Disabled!
7	●	●	Digital Input 7	Disabled!
8	●	●	Digital Input 8	Disabled!

Illustration 23 – Service PLC-Inputs

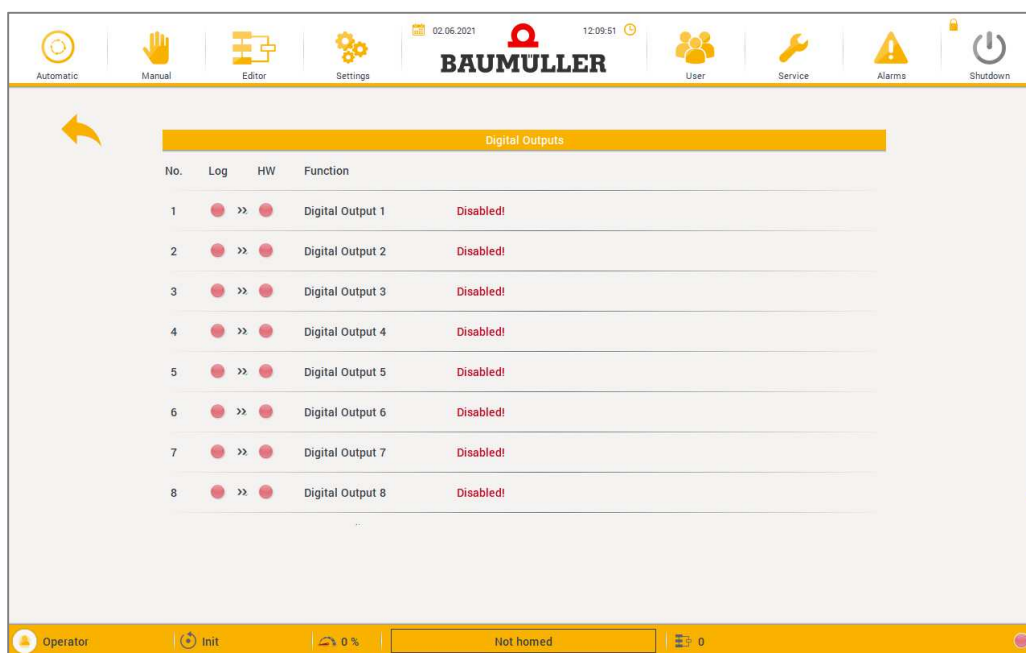

No.	Log	HW	Function	Status
1	●	●	Digital Output 1	Disabled!
2	●	●	Digital Output 2	Disabled!
3	●	●	Digital Output 3	Disabled!
4	●	●	Digital Output 4	Disabled!
5	●	●	Digital Output 5	Disabled!
6	●	●	Digital Output 6	Disabled!
7	●	●	Digital Output 7	Disabled!
8	●	●	Digital Output 8	Disabled!

Illustration 24 – Service PLC-Outputs

The interface data structure is already prepared for extension with the I/O module, but the logic for processing the I/O signals is not yet integrated in the control unit. This can be implemented analogously to the programming of the drive inputs/outputs.

8.10.3 Drive inputs/outputs

On these pages of the user interface, the digital inputs and outputs of the drives are displayed and their current state is shown. The desired drive can be selected via a drop-down list.

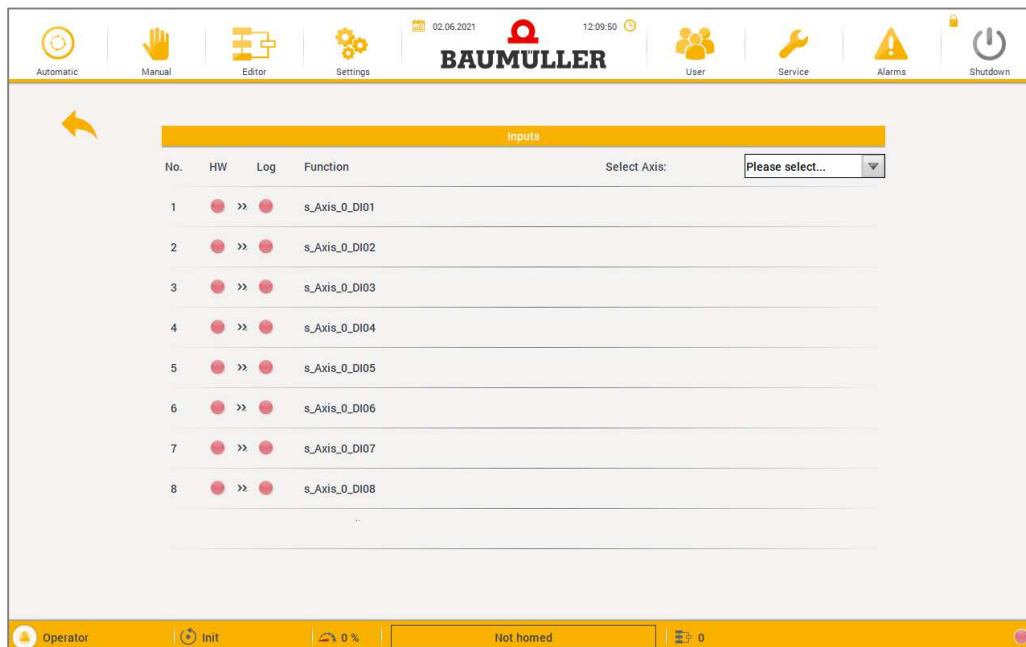

Illustration 25 – Service Drive inputs

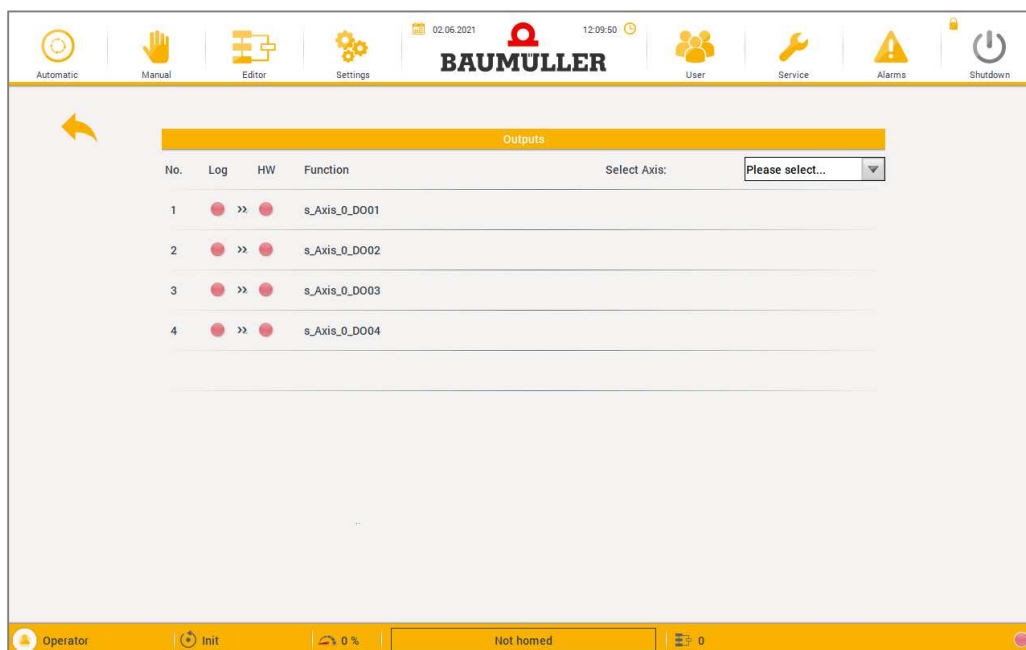
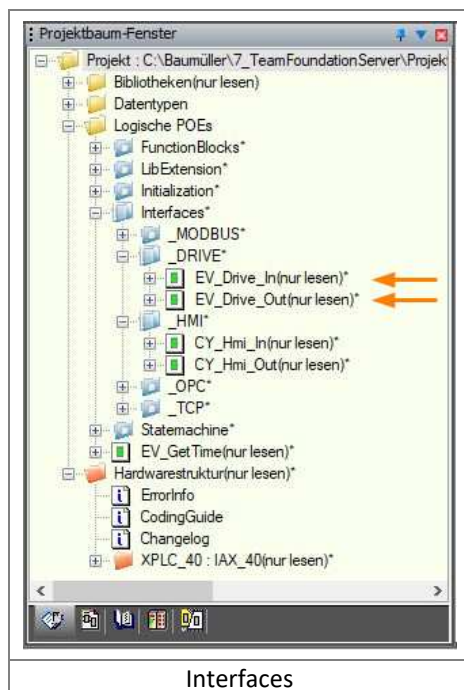

Illustration 26 – Service Drive outputs

The interface to the drive can be found in the Interfaces area of the control. In the POU with the suffix "_In", the PII is created and the data is copied into the controller-internal data structure "Iface" for further processing. In the POU with the suffix "_Out", the required data is read from the "Iface" data structure, copied into the PIQ and forwarded to the corresponding drive.



For commissioning or diagnostics, it is possible to manually manipulate the current state of the inputs/outputs. In this case, not the HW logic level but the logic level set by the user is transferred to the PAE of the PLC for the current signal. This option is available from user level 3.

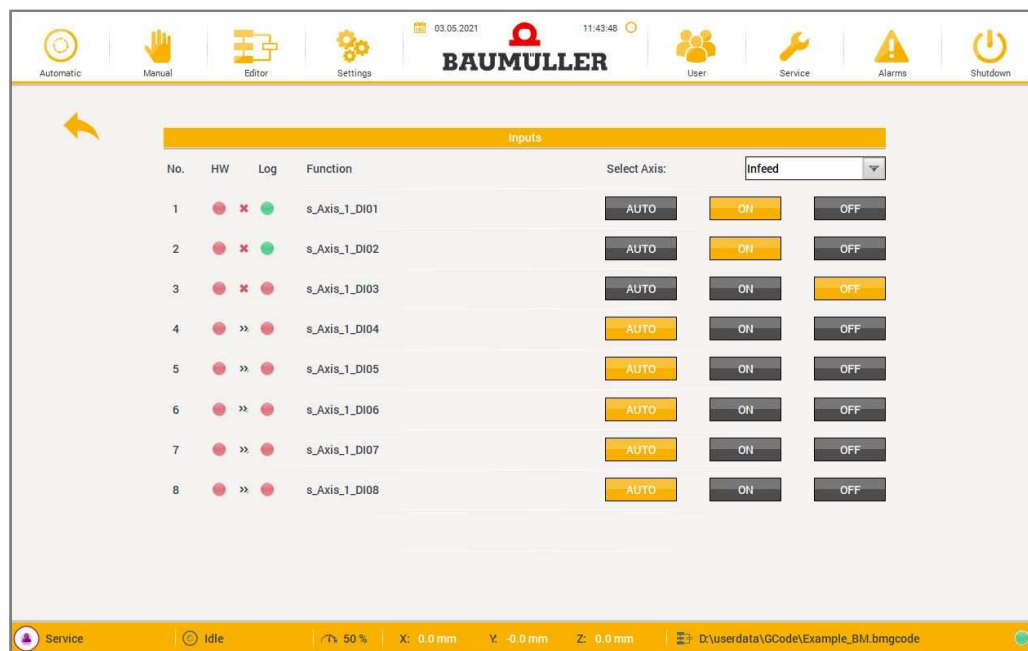









Illustration 27 – Service forcing inputs/outputs

Symbol	Description
	Input: The HW logic level is transferred directly to the PII of the PLC. Output: The PIQ of the PLC is written directly to the HW output
	Input: The HW logic level is <u>not</u> transferred to the PII of the PLC. Output: The PIQ of the PLC is <u>not</u> written to the HW output
	Input: A high level is transferred to the PII of the PLC for the input. Output: A high level is written to the HW output.
	Input: <u>No</u> high level is transferred to the PII of the PLC for the input. Output: <u>No</u> high level is written to the HW output.
	Input: A low level is transferred to the PII of the PLC for the input. Output: A low level is written to the HW output.
	Input: <u>No</u> low level is transferred to the PAE of the PLC for the input. Output: <u>No</u> low level is written to the HW output.

WARNING	
	<p>If the pulse enable of a drive was set manually, the drive is enabled for operation regardless of the machine state, i.e. the inverter outputs power. It must be ensured that there are no persons in the working area!</p>

8.10.4 System

General information on the user interface and control system is summarised here, e.g. name of the currently loaded PLC project, current firmware of the PLC, and so on.

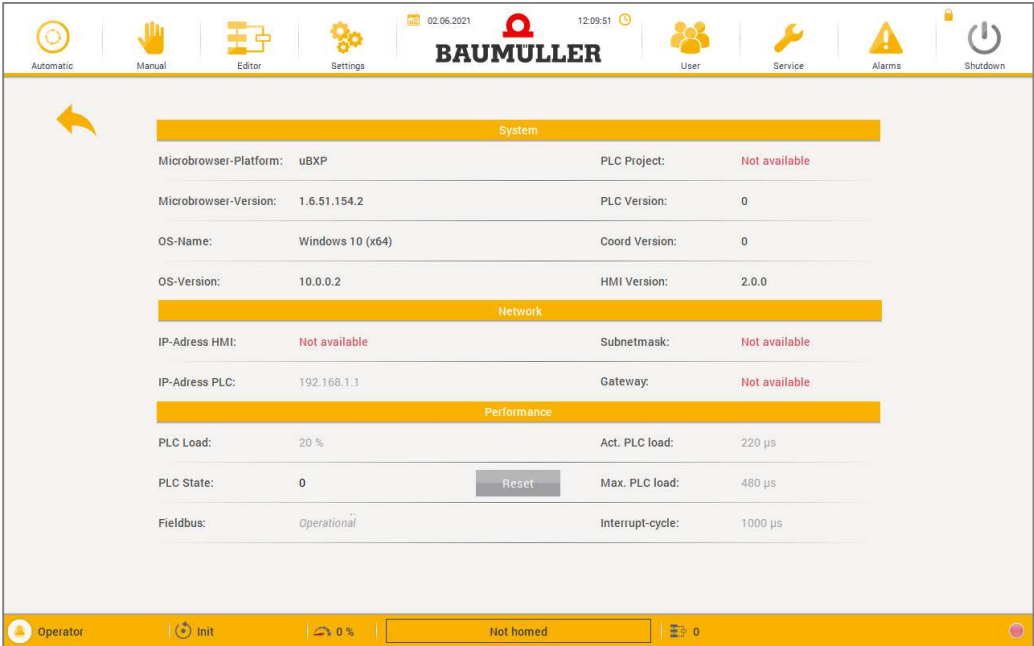

Illustration 28 – Service System information

8.10.5 Monitoring

For diagnostic purposes, a trend service is available, which displays the current positions and velocities of the axes.

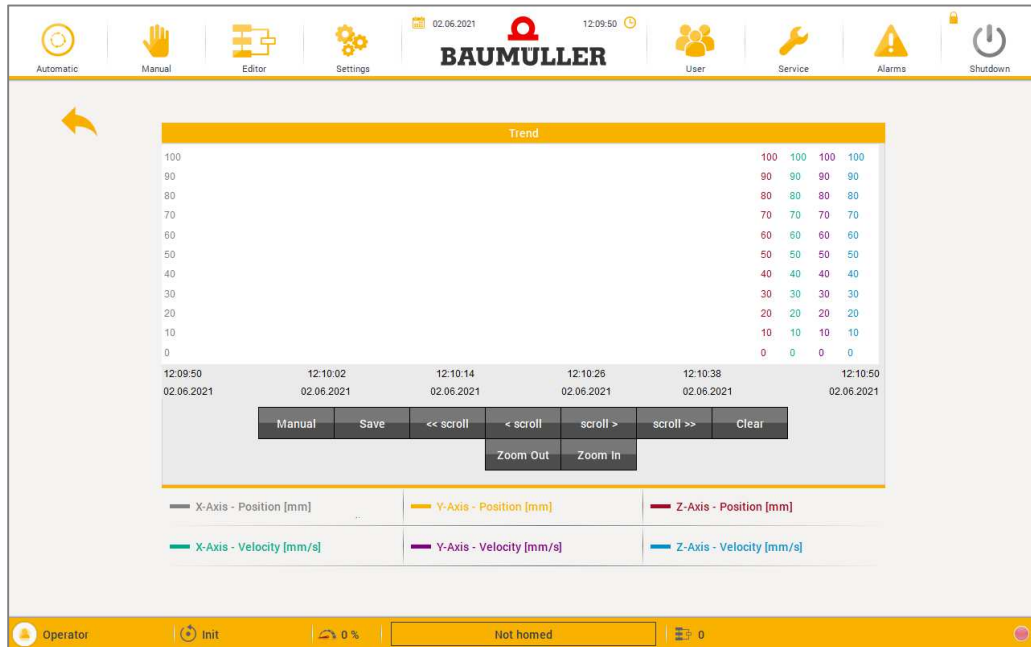

Illustration 29 – Service monitoring

8.11 Alarms

On the alarm page, all currently active errors of the system are displayed and reset upon request. An overview of the possible messages can be found in the chapter [Error list](#).

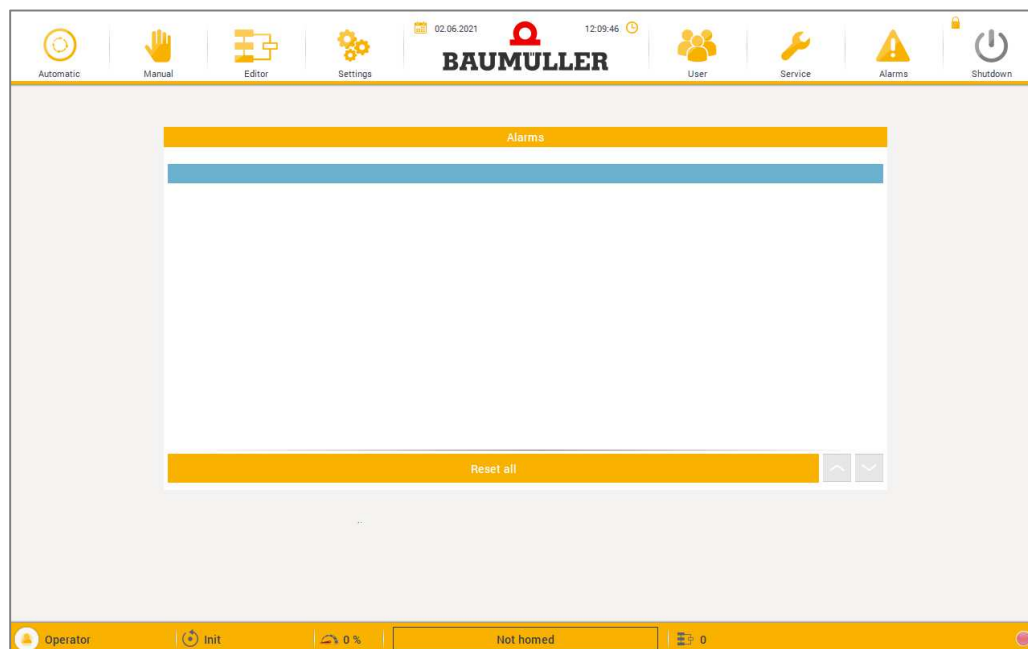

Illustration 30 – Error list

- **Reset all:** reset all active errors

After an error has occurred, it is written into the error list with a time stamp and marked as follows:

TID	Alarm Text	On	Off	ACK
9	Not-Aus betätigt	29.03.2017 16:01:17	-	NAK

After an error has been successfully reset, the acknowledgement with time stamp is written into the error list and marked as follows:

TID	Alarm Text	On	Off	ACK
9	Not-Aus betätigt	29.03.2017 16:01:17	29.03.2017 16:01:36	NAK

The error management function can be found in the CY_ErrorHandler area of the controller. Here, all errors are summarised and stored until they are reset by the operator.

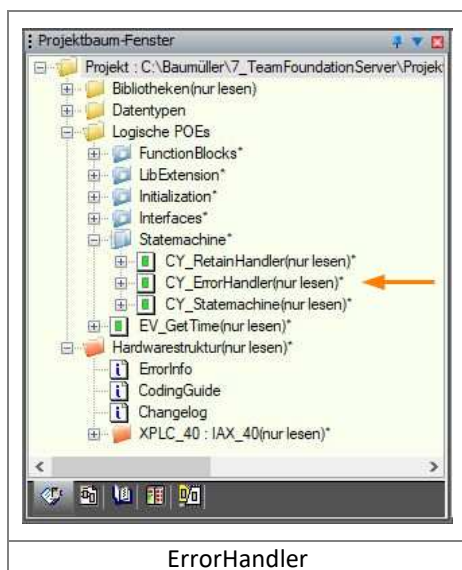

ErrorHandler

If necessary, the error management can be quickly expanded and adapted to the respective application.

8.12 Shutdown of the machine

The machine can be shut down or restarted via the corresponding control panel on the navigation bar. At least user level 1 is required for this. After pressing it, the following drop-down menu opens.

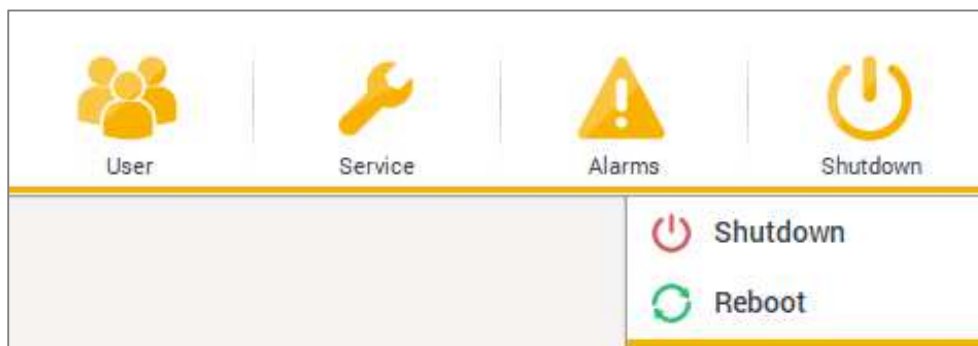

The machine axes are switched off in a controlled manner and any brakes that may be present are locked in. Changes that have not been saved are lost and will not be available after a restart.

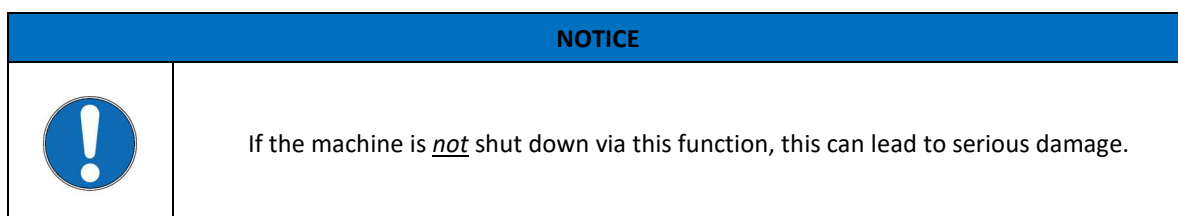

There is another "Exit" option available from user level 4. This can be used to close the visualisation in order to carry out software updates, for example.

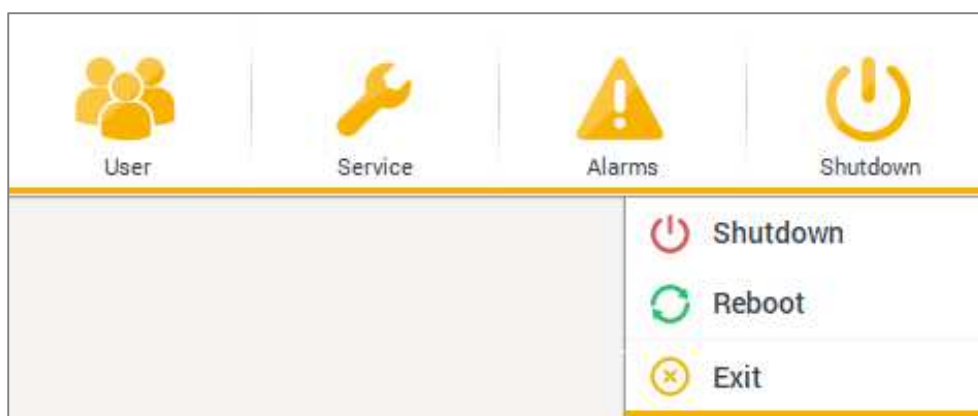

8.13 Virtual Event Generator

During software development, the programmer has the possibility to carry out function tests without peripherals (drives, touch display, I/O module, etc.), i.e. exclusively with the PCC-04.

Because the controller is a cyclic PLC with interrupt processing and in this case the interrupt event from the fieldbus is missing, a virtual event generator must be used. Otherwise the time-critical POU's will not be processed.

In the *Global Variables* area, there is the *Virtual_Event_Generator* group with the corresponding variables.

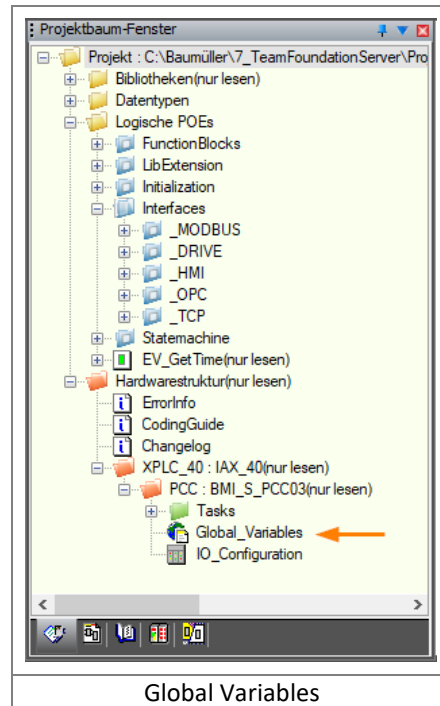

By default, the Virtual Event Generator is deactivated:

Name	Typ	Verwendung	Beschreibung	Adresse	Anfangswert
Virtual_Event_Generator					
x_OperatingModeVirtual	BOOL	VAR_GLOBAL	Fully Virtual -->> Standalone -->> If TRUE -->> Enable VirtualEventGenerator!		FALSE
w_VirtualEventGeneration_1	WORD	VAR_GLOBAL	Note: Disable all variables of VirtualEventGeneration (3x), if	%MW3.2016448	16#6973
w_VirtualEventGeneration_2	WORD	VAR_GLOBAL	at least one client (Axis) is connected to the fieldbus	%MW3.2016640	16#756D
b_VirtualEventGeneration_3	BYTE	VAR_GLOBAL	3 = Virtual Master State Operational	%MB3.2016663	

To activate the Virtual Event Generator, the entries must be changed as follows:

Name	Typ	Verwendung	Beschreibung	Adresse	Anfangswert
Virtual_Event_Generator					
x_OperatingModeVirtual	BOOL	VAR_GLOBAL	Fully Virtual -->> Standalone -->> If TRUE -->> Enable VirtualEventGenerator!		TRUE
w_VirtualEventGeneration_1	WORD	VAR_GLOBAL	Note: Disable all variables of VirtualEventGeneration (3x), if	%MW3.2016448	16#6973
w_VirtualEventGeneration_2	WORD	VAR_GLOBAL	at least one client (Axis) is connected to the fieldbus	%MW3.2016640	16#756D
b_VirtualEventGeneration_3	BYTE	VAR_GLOBAL	3 = Virtual Master State Operational	%MB3.2016663	

Notiz!



The project must be recompiled and then transferred to the controller and the controller must be completely restarted (e.g. by script). Furthermore, no fieldbus peripherals can be connected to or used with the PCC as long as the Virtual Event Generator is active!

9. Error list

ID	Description	Solution
01	Error - PLC cycle time exceeded	
02	Error - PLC event time exceeded	
03	Warning - Interface data struct size >=90%	
04	Error - Interface data struct size exceeded	
05		
06	Error - EtherCat Master is not Operational	
07	Error - At least 1. EtherCat Slave not Operational	
08		
09		
10		
11	Error - Motion Control	
12	Error - Coordinated Motion	
13	Error - Emergency stop pressed	
14		
15		
16		
17	Error - Main rectifier unit not ready	
18		
19		
20		
21	Error - Drive controller X-Axis	
22	Error - Drive controller Y-Axis	
23	Error - Drive controller Z-Axis	
24		
25		
26		
27	Warning - Drive controller X_Axis	
28	Warning - Drive controller Y_Axis	
29	Warning - Drive controller Z_Axis	
30		
31		
32		

10. List of illustrations

Illustration 1 – System structure	6
Illustration 2 - Programme flow chart (simplified).....	7
Illustration 3 – Navigation bar.....	8
Illustration 4 – Status bar	10
Illustration 5 – Initialization	12
Illustration 6 – Home.....	13
Illustration 7 – Automatic	15
Illustration 8 – Manual (referenced)	18
Illustration 9 – Manual (not referenced).....	18
Illustration 10 – Notepad++ G-Code Editor.....	22
Illustration 11 – Overview Settings	23
Illustration 12 – Settings General.....	25
Illustration 13 – Settings Interface.....	27
Illustration 14 – Settings Language	28
Illustration 15 – Settings User management.....	29
Illustration 16 – Settings Homing.....	30
Illustration 17 – Settings Kinematic	31
Illustration 18 – Settings Axis group dynamics	32
Illustration 19 – Settings single axes dynamics	32
Illustration 20 – User login	33
Illustration 21 – User login (HMI-Project)	34
Illustration 22 – Overview Service	35
Illustration 23 – Service PLC-Inputs.....	37
Illustration 24 – Service PLC-Outputs.....	37
Illustration 25 – Service Drive inputs	38
Illustration 26 – Service Drive outputs.....	38
Illustration 27 – Service forcing inputs/outputs	39
Illustration 28 – Service System information	40
Illustration 29 – Service monitoring.....	41
Illustration 30 – Error list	42