



**Operating instructions including
the safety instructions**

be in motion be in motion



TAM 00713

DS2 100 – 200

Three-phase synchronous motor

Version: 04/ 2021

English



LEGAL INFORMATION ABOUT THE DOCUMENTATION

Copyright

This commissioning and maintenance instruction may be copied by the owner in any quantity and is exclusively for internal use, only. This commissioning and maintenance instruction may not be copied or reproduced in whole or in part for any other purposes. The use and disclosure of information contained in this commissioning and maintenance instruction is not permitted. Designations and company marks contained in this documentation could be trademarks, the use of which by third parties for their own purposes could violate the rights of the rights holder.

Obligatory

This commissioning and maintenance instruction is part of the device / the machine. This commissioning and maintenance instruction must be available to the user at all times and must be in a readable condition.

After sale / relocation of the device / machine the original including all the copies of the commissioning and maintenance instruction must be passed on to the purchaser. After disposal or any other end of period of use this commissioning and maintenance instruction and all its copies must be disposed of.

After handing over the present commissioning and maintenance instruction previous versions of corresponding sets of the commissioning and maintenance instruction now are invalidate.

Please, note that the specifications / data / information are current values according to the printing date. These statements are not legally binding regarding measurements, computation or calculations.

The company Baumüller Nürnberg GmbH reserves the right, in developing its products further, changing the technical specifications and handling of its Baumüller products without prior notice.

However, no liability can be accepted concerning the correctness of these commissioning and maintenance instructions unless otherwise specified in the General Conditions of Sale and Delivery.

BAUMÜLLER NÜRNBERG GmbH

Motors business unit

D-90482 Nuremberg

www.baumueller.de

Lists of contents

1.1	Safety.....	4
1.2	Intended use	5
2	Operating requirements	6
2.1	Product description	6
2.2	Scope of supply	6
2.3	Type plate	7
2.4	Technical data.....	8
2.4.1	Technical data in general	8
2.4.2	Technical data for air-cooled motors.....	9
2.4.3	Technical data for liquid-cooled motors	9
2.5	Definition of performance.....	10
2.5.1	Definition of performance for air-cooled machines	10
2.5.2	Performance definition for water-cooled machines	10
2.6	Transport, temporary storage	11
2.7	Installation conditions; cooling information	12
2.8	Balancing, output elements and vibrations	13
3	Mounting	14
3.1	Safety notes.....	14
3.2	Installing, attaching	15
3.3	Vibrations and resistance to vibrations	16
3.4	Electric connection.....	17
4	Commissioning, operation	19
4.1	Safety notes.....	19
4.2	Tests before commissioning	20
4.3	Commissioning, operation	20
4.4	Failures	21
5	Inspection and maintenance	22
5.1	Inspection.....	22
5.2	Maintenance	23
6	Disposal	23
7	Appendix 1: Pole assignments (power and control connections).....	24
7.1	Main connection via terminal box.....	24
7.2	Control connection: Resolver.....	26
7.3	Control connection : SRS / SRM 50.....	26
7.4	Control connection : ECN 1313 / EQN 1325.....	27
7.5	Control connection : ECN 1325 / EQN 1337 (absolute value encoder with Endat 2.2-interface of the company Heidenhain).....	28
7.6	Fan connection / terminal markings	29
Table 5:	Data fan connection	29
8	Anhang 2: Water cooling	30
8.1	Specifications referring to the required cooling flows.....	30
8.2	Media-contacting materials in the motor	30
8.3	Motor cooling	30
8.4	Mounting notes	31
8.5	Electrical connection.....	31
8.6	Cooling water status	31
8.7	Minimum coolant temperature in dependence of the environmental conditions.	32
8.8	Failures	34
8.9	Inspection.....	34

1 General safety notes

1.1 Safety

This electric motor was built referring to the current state of the art of safety technology and was checked on its operational safety before it left the company.

Please, consider the following to ensure a proper commissioning as well as the safe use:

- The present commissioning and maintenance instruction and its enclosed additional parts
- The enclosed safety and commissioning instructions
- The technical documents of the product
- The commissioning and safety notes of the manufacturer of the converter
- The national, local and plant-specific regulations related to the finished product
- The technical instruction TAM 00697 when using the safety-related applications

When using this product the following dangers must be considered:

- Dangers due to
- Lifting and transport processes
 - Electrical current
 - Moving parts
 - Hot surfaces
 - EMC interferences
 - Mechanical overload
 - Thermal overload

In order to avoid dangers against persons and material assets or to minimize existing risks please regard all safety notes especially those which are marked by symbols.



Danger to life from electrical current

Non-observance can cause the death or severe injuries.



Warning about general dangers

Non-observance can cause severe injuries or material damage.



Warning about dangerous situation

Non-observance can damage the system and also the vicinity.



Do not touch!

Non-observance can cause severe injuries.



No Inadmissible actions!

Non-observance can cause severe injuries



Warning about hot surfaces

Non-observance can cause severe injuries



Magnetic field warning.

Failure to observe can lead to severe injuries or damage to property.



Electrostatically sensitive components

Non-observance can damage the system or the vicinity

1.2 Intended use

The use of the electric motor is permitted within its intended use. In this connection the electric motor may only be used in the provided applications in the technical documents considering all notes of this commissioning and maintenance instruction.

All workings regarding the mounting, commissioning and maintenance as well as during operation may be carried out by **qualified personnel**, only.

Qualified personnel is to be understood a trained and authorized person in the sense of the safety engineering notes qualified within a subject area who has the right to install, to mount, to commission and to operate devices, systems and circuits on the basis of the safety standards established. (EN 50110-1) .

Improper behavior can cause **severe injuries and damage**.

This **electric motor** is used in **industrial systems** and complies to the following **standards and directives**:

Standards

EN 60034-1, EN 60034-5, EN 60034-6, EN 60034-7, EN 60034-9, EN 60034-11, EN 60034-14, EN 60204-1

EU Low Voltage Directive

Electric motors of this series comply with the requirements of the Low Voltage Directive 2014/35/EU (conformity)

EU Machinery Directive

Electric motors are components which are intended to be installed in machines as described in the Machinery Directive. Commissioning is not permitted until such time as the conformity of the finished product with this directive has been established (refer to EN 60204-1 "Electrical Equipment of Machines").

EU EMC Directive

The operation of the electric motor within its intended use must meet the protective requirements of the EMC Directive. The constructor of the system as well as the system provider are responsible for the appropriate installation (e.g. spatial separation of signal cables and power cables, screened lines and cables etc.). In converter operation the EMC notes of the current converter, the encoder as well as of the brake manufacturer must be complied with.

All national, local and system-specific regulation must be complied with as well!

The electric motor is designed for the following **environmental conditions**:

- Environmental temperature: 0 °C bis +40 °C
- Installation height: ≤1000 m above sea level
- Relative humidity: 5 % to 85 %

Please, regard possible deviating statements on the type plate or in the technical documents. The conditions at the operation site must comply with all specifications defined on the type plate.



The use in hazardous areas **is forbidden**, unless explicitly provided for this purpose (regard additional notes). Furthermore, there may not be flammable gas mixes and dangerous dust concentrations in the vicinity of the electric motor. Voltage-carrying and hot motor parts could catch fire and cause severe injuries and material damages.

If there should be the special case of the use in systems which are not industrial, higher demands are required (e.g. protection against children's fingers), these conditions must be ensured at the system.

Motor type with rare earth magnets:

	<p>Near a drawn or exposed rotor having a strong magnet the following danger can occur:</p> <ul style="list-style-type: none">• Persons having electronic or metallic implants (e.g. pacemakers, hearing devices, plates or nails) are endangered, if the distance between the implant and the magnet pole is less than 0.5 m.• Due to the forces of attraction towards ferromagnetic parts the following can occur:<ul style="list-style-type: none">○ Risk of crushing injury○ Risk of destruction of measuring and assembly tools, check cards, watches etc.○ Pollution of the rotor package caused by drawn-in metal chips or powder.
---	--

Thermal danger:

	<p>Danger of burning!</p> <p>Surface temperatures of over 70°C can occur at the motors. If required provide touch protection!</p> <p>At hot surfaces temperature-sensitive parts as for example normal supply lines or electronic parts may not be applied or fixed.</p> <p>A thermal overload of the motors can cause the destruction of the winding, of the bearings and the demagnetizing of the rare earth magnets. Use the temperature sensor to check the temperature.</p>
---	---

Prohibition of arbitrary modifications and changes

	<p>Any kind of arbitrary modifications and changes at the electric motor is not permitted. If required, please, contact the motor manufacturer.</p> <p>It is not permitted to demount or shut down safety equipment in order to operate the electric motor.</p>
---	---

2 Operating requirements

2.1 Product description

The three-phase synchronous motors of the **DS2** series are air-cooled or water-cooled permanently excited synchronous motors. Designed for a very high power density, a very high efficiency and high dynamic the motors are ideally suited for high-end applications in the machine building industry. This is even more supported by its high overload capability. Furthermore, the robust and compact motors are to the greatest possible extent maintenance free, which is an additional benefit to the economical operation. The structure is very compact due to the use of liquid cooling and the noise emission is considerably reduced.

2.2 Scope of supply

The supply is compiled order-related.

- Damage that incurred during transit must immediately be reported to the transport company.
- Immediately after receiving the delivery compare the performance data of the delivered motor with your ordering data. If visible defects or insufficient delivery is determined then immediately contact the responsible Baumüller subsidiary or the main Baumüller company in Nuremberg.

In both cases the defect must be corrected at first before the motor can be commissioned.

2.3 Type plate

The type plate (figure 1 and figure 2) is the identifier for each electric motor. Especially, the motor number is distinctive for each electric motor – this number is essential to make a back-tracing in our company possible. Therefore the type plate always must be readable. Never remove the type plate from your motor.

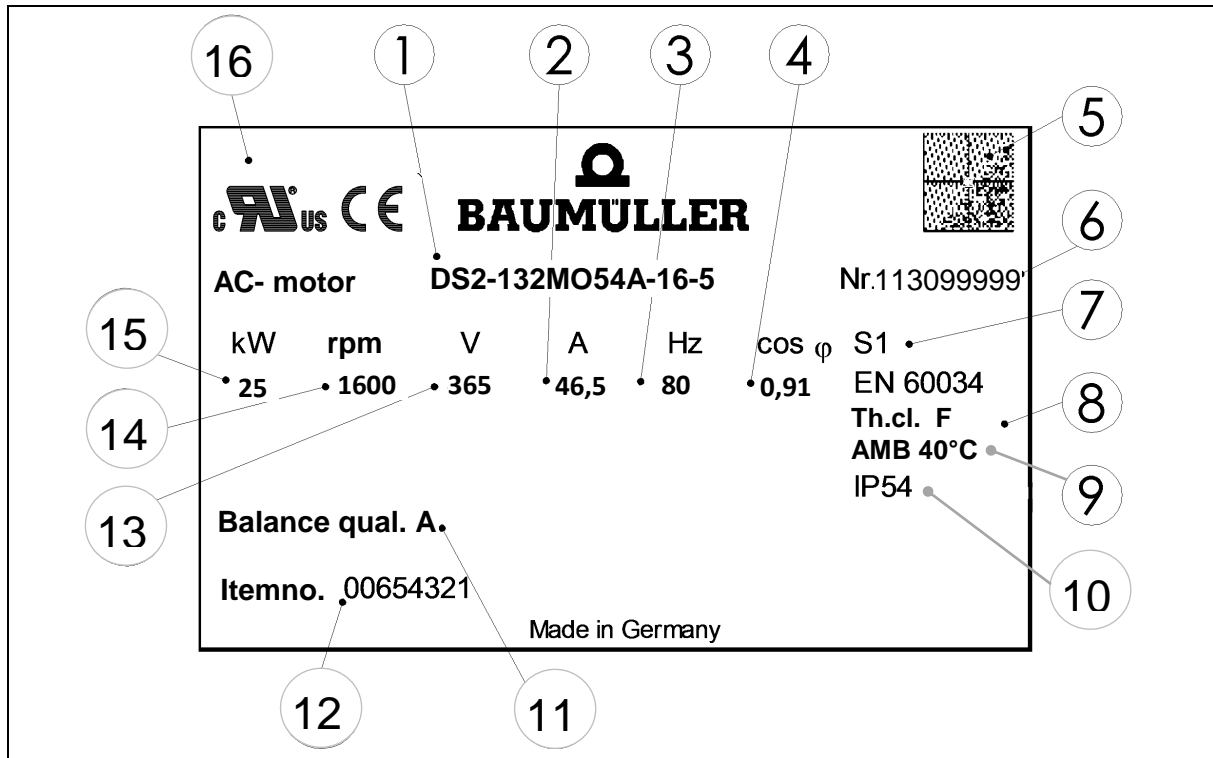

Figure 1: Type plate size 160-200

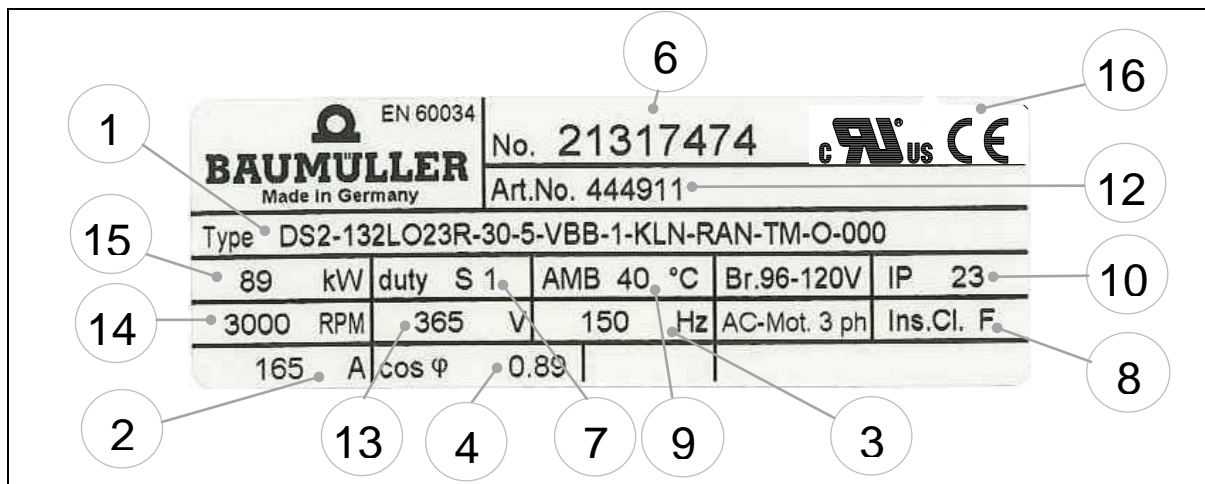



Figure 2: Type plate size 100-132

- | | | | |
|---|--------------------------|----|---------------------------|
| 1 | Motor type / designation | 9 | Environmental temperature |
| 2 | Rated current | 10 | Motor type of protection |
| 3 | Rated frequency | 11 | Quality of vibration |
| 4 | Power factor | 12 | Part number |
| 5 | 2D code | 13 | Rated voltage |
| 6 | Motor number | 14 | Rated speed |
| 7 | Motor operation mode | 15 | Rated power |
| 8 | Temperature class | 16 | Standards and approvals |

2.4 Technical data

2.4.1 Technical data in general

Size	B3	Size 100-200
	B5	Size 100-200 (size 200 water-cooled only)
	B35	Size 100-200
Connection	Main connection	U V W (terminal box)
	Encoder connection	Connector socket 12- or 17-pole, plug 9-pole for EnDat 2.2
	Temperature sensor	In the main connection
Brake		Axial ventilation: Plug 8-pole Radial ventilation or water cooling: Terminal version
Temperature sensor	KTY84-130	Linear temperature sensor to evaluate in the controller
Temperature increase	$\Delta\delta \leq 105 \text{ K}$	Insulation class F acc. to EN 60034
Environmental conditions in the company	Class 3K3/3Z12 according to DIN EN 60721-3-3, however: Temperature range 0 to 40°C	Accords to 0 to 40 °C at 5 % to 85 % rel. humidity and an absolute humidity of 1 g/m ³ to 25 g/m ³ and an altitude up to about 1400 m
Environmental conditions at long-term storage	Class 1K2/1M1 according to DIN EN 60721-3-1, however: temperature range - 15 to 60°C	Accords to - 15 to 60°C at 5 % to 85 % rel. humidity and an absolute humidity of 1 g/m ³ to 25 g/m ³ ; to avoid frost damages at temperatures lower than 3°C the cooling water must be drained.
Environmental conditions at transport	Class 2K2/2M1 according to DIN EN 60721-3-2, however: Temperature range - 15 to 60°C	entspricht - 15 bis 60°C bei 5 % bis 85 % rel. Feuchte und einer absoluten Feuchte von 1 g/m ³ bis 25 g/m ³ ; to avoid frost damages at temperatures lower than 3°C the cooling water must be drained.
Surface	Black matt	RAL 9005
Bearings	A end	Floating bearing: Ball bearing (standard); option roller bearing
	B end	Fixed bearing: Ball bearing
Service life of bearing	L _{H10} 20.000 h	Guide value, for-life grease-lubricated rolling-contact bearing
Vibration resistance		See point 3.3
Concentricity	N	Standard: Normal acc. to DIN 42955
	R	Option: Size 100-160, ball bearing only
Vibration-resistant to	radial 3 g / axial 1 g	Standard: 10 Hz to 55 Hz acc. to EN 60068-2-6
Flange	FF flange	According to IEC standard
Shaft end	Cylindrical	According to DIN 748; centering with inside thread according to DIN 332 form D Option; with featherkey according to DIN 6885
Actual speed value encoder	Resolver 2-pole	Standard: See Appendix 1
	Sincos/EnDat encoder	Option: See Appendix 1
Holding brake	Disk brakes	Option: Addition B ended as a module (size 100-160)

Approvals	Baumüller brand	Other brands on request
	CE, 	Standard
	CE	DS2-160 including an axially integrated fan

2.4.2 Technical data for air-cooled motors

Cooling method / type of protection	IC 06 / IP23	Ventilated machine with fan
	IC 416 / IP54	Ventilated machine with fan

Attention: All mentioned degrees of protection are reached only, if the plug connectors are mounted completely and the terminal box is completely closed.

Forced ventilation	Normal fan motor for radial ventilation on the B end Fan filter	Direction of air flow from B to A IC 06: Air escape laterally to the A end IC 416 Air escape axial A end Option: Flat filter or rectangle filter
	Normal fan motor for axial ventilation on the B end	Direction of air flow from A to B Direction of air flow laterally to the B side
	Axially integrated fan for axial ventilation on the B end	Direction of air flow from A to B Air escape laterally to the B end

Connection fan motor	Added-on standard motor	Terminal box standard motor
	Added-on fan motor	Connector 6-pole

Terminal box	B end	Positioning options see Separately driven fan
	A end	On request



2.4.3 Technical data for liquid-cooled motors

Cooling method / degree of protection	IC3W7 / IP54	Water-cooled machine
---------------------------------------	--------------	----------------------

Attention: All mentioned degrees of protection are reached only, if the plug connectors are mounted completely (main and control connection) and the terminal box is completely closed.

Terminal box	B end	Top
Coolant inlet temperature	10°C to 25 °C	Maximal 5 K lower than the environmental temperature
Water connections	A end	Laterally

Other characteristic values are to be found in our technical product list **DS2 100 –200** on the Internet page: www.baumueller.de in the download area in “Technical documentations”. Please, contact us for further documents.

Attention!

If the supplied electric motor doesn't correspond to the general version according to the technical list or if special agreements were stipulated, the technical deviations corresponding to this commissioning and maintenance instruction can occur. In this case, please, contact us to receive the corresponding technical additions.

2.5 Definition of performance

2.5.1 Definition of performance for air-cooled machines

The performances (torques) mentioned in the technical product list apply to the continuous operation (S1 having the nominal speed at a maximum environmental temperature of 40°C if the machines are built up beneath 1000 m above sea level. If motors are to be used within an environmental temperature of more than 40°C or at higher altitudes over 1000 m above sea level. If motors are to be used in an environmental temperature of more than 40°C or in altitudes over 1000 m above sea level, the required list performance P_1 results (list torque M_n) from the product in **Table 1** of the specified factors k_1 , k_2 and of the demanded performance P (torque M).

Environmental temperature	40°C	45°C	50°C	55°C
Correction factor k_1	1	1,06	1,13	1,22
Altitude above sea level up to	1000 m	2000 m	3000 m	4000 m
Correction factor k_2	1	1,07	1,16	1,27

Table 1: Correction factors for air-cooled motors

At environmental temperatures over 40°C and if the motors were built in encapsulated, please contact the manufacturer as it could be that mechanical measures to cool the motor must be taken into account.

If the environmental temperature sinks by about 10°C per 1000 m height growth, then no correction of the performance is required (pay attention to the minimum operating temperature).



2.5.2 Performance definition for water-cooled machines

The mentioned performances (torques) in the technical product list apply to the continuous operation S1 with rated speed as long as the demands to the cooling system for water-cooled motors are complied with!

During the operation of the DS2 motors with higher coolant inlet temperatures the reduction factors in **Table 2** must be considered:

Coolant inlet temperature	25 °C	30 °C	35 °C	40 °C	45 °C
Percentage of list performance (torque)	100 %	97 %	95 %	92 %	89 %

Table 2: Reduction factors

2.6 Transport, temporary storage

Water-cooled motors:

	<p>In order to avoid frost damage it must be ensured that there is no coolant in the motor during the transport or at a temporary storage at environmental temperatures $< 3\text{ °C}$. The coolant can be purged with compressed air.</p>
---	---

Transport:

	<p>The permitted environmental conditions that may act on the motor during the transport is to be taken of DIN EN 60721-3-2 (class 2K2/2M1). The permitted temperature range was contrary to the DIN reduced to -15 °C to $+60\text{ °C}$.</p> <p>Suitable load carrying devices are to be used as for example belt straps, single slings etc. If the motor provides lifting lugs they as well can be used for lifting purposes.</p> <p>The terminal boxes and motor connectors may not be used as transport safety or as lifting lugs.</p> <p>During transport the correspondent country-specific regulations must be complied with. Lifting devices, transport and load bearing devices must comply with the regulations.</p>
---	--

The weight of the individual electric motors is given in the technical documents of the product.

Bearing protection: (at motors with cylindrical roller bearings)

	<p>To avoid transport damages at motors with cylindrical roller bearings the rotor is blocked by means of a transport protection at the shaft end.</p> <p>This transport protection must be used for further transports again.</p> <p>If this protection cannot be used anymore due to the fitting of an output element, other measures must be made to axially fix the rotor for transport.</p>
---	---

Temporary storage:

If a motor isn't taken into operation promptly after delivery it must be stored in an internal space which is dry, low-vibrated and with little dust ($V_{\text{eff}} \leq 0,2\text{mm/s}$).

The electric motors should not be stored more than 2 years at a preferably consistent temperature and not outside the temperature range between -15 and $+60\text{ °C}$. Higher storing temperatures as those of the service temperature will cause accelerated aging of the seals and of the bearing grease and conclusively will have negative effects on the operating life before commissioning. Furthermore, direct sunlight, UV light and ozone as well cause aging of the sealing elements and should absolutely be avoided as well!

Please, consider that the warranty period is guaranteed from date of delivery. We, therefore, recommend reducing storage time to a minimum.

However, if a longer storage time cannot be avoided then comply with the environmental conditions of the DIN EN 60721-3-1 (class 1K2/1M1). Contrary to the DIN the temperature range may be expanded to -15 °C bis $+60\text{ °C}$.

2.7 Installation conditions; cooling information

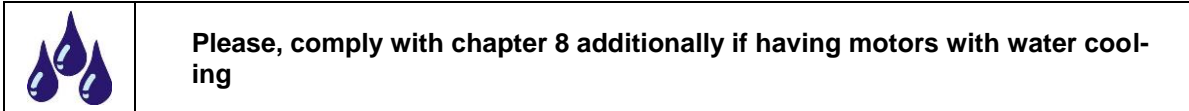

Environment:

Accordant to its degree of protection (see motor type plate) the motor can be installed in a roofed room in a dusty or humid environment as well as in normal climatical conditions.

As long as no special agreements were made the drive is applied to the following climatical using conditions:

- Environment temperature 0 °C to 40 °C
- Installation altitude ≤ 1000 m above sea level
- Relative humidity 5 % to 85 %

All the other permitted operating conditions are to be taken from the DIN EN 60721-3-3 (class 3K3/3Z12).

These climatical conditions are essentially to be considered at installation.

Aggressive, corrosive, abrasive as well as plastic-dissolving media must be kept away from the motor in general.

The motor manufacturer must be contacted if an outdoor installation is intended.

Air cooling:

Attention should be paid to the following:

- The thermal convection and the heat radiation may not be affected by the installation conditions
- The cooling air must be able to freely flow in at forced air cooling and the warm air must be able to freely flow off. The heated exit air may not be drawn in again.
- The distance to the adjacent machine parts should not fall below 100 mm.
- The housing surface as well as the ventilating paths are to be cleaned if there is a strong dirt accumulation.

Details on the required cooling volume

The following cooling volumes are required to cool the DS2 motors (**Table 3**):

Size	100	132	160	200
Air quantity at least in m ³ /min	$\geq 2,4$	$\geq 5,8$	$\geq 9,5$	$\geq 16,5$
Pressure altitude at least in Pa	≥ 180	≥ 370	≥ 640	≥ 850

Table 3: Required cooling quantity

2.8 Balancing, output elements and vibrations

	<p>Don't stress the shaft and the bearings with shocks.</p> <p>Axial forces aren't permitted during the mounting and demounting of output elements. The required measures referring to the contact protection of the output elements in general must be regarded</p> <p>If a motor is put into operation without output elements then the featherkey must be protected against being ejected..</p>
---	--

Balancing:

In the standard version the rotor is dynamically balanced with a half featherkey (accordant to EN 60034-14 / ISO 8821 / ISO 1940)

Note: Regard the identification of the balancing type at the shaft end face:

H = Balancing with half the featherkey **Standard version**
F = Balancing with the complete featherkey **Special version**

Output elements:

When mounting the output elements the accordant balancing must be considered. The output elements must be balanced complying with ISO 1940.

When fitting and removing the output elements (e.g. coupling disks, rack-wheels, pulley wheels) adequate facilities must be used.

- Use thread hole in the end of the shaft.
- During removal use spacing washers to mechanically protect the shaft.
- If required before fitting warm up the output elements (max. permitted temperature at the shaft end is 150 °C for a short time).

Attention:

- At the shaft version without featherkey the drive elements are to be fixed on the output shaft **by means of appropriate clamping sets.**
- At shaft versions with featherkey it must be considered that the **output elements are applied to the shaft shoulder.** Note: The bevel and the radius at the output element and the shaft radius towards the shoulder (accordant to DIN748-1) must be compatible.
- If the threaded hole in the shaft end is used to protect the output elements axially (e.g. pulley wheels), the tightening torques in **Table 4** may not be exceeded:

	Thread	Tightening torque in Nm
	M10	19,0
	M12	33,0
	M16	80,0
	M20	160,0

Table 4: Tightening torques using the example of a locking bolt S of a pulley wheel

Appropriate measures are to be used to protect the screws!

Vibrations:

	<p>The system's vibration response at the location caused by output elements, installation options, alignment and setup as well as influences of external vibrations can cause an increase of vibration values at the motor.</p> <p>Considering a correct functioning of the motor and a long bearing service life the permitted vibration values accordant to EN 60034-14 may not be exceeded. It may be necessary to balance the complete rotor with the drive element (according to ISO 1940).</p> <p>The limited vibration loads and accelerations after mounting are not to be exceeded, refer to chapter 3.3</p> <p>At changes compared with the normal operation – e.g. increased temperatures, noises, vibrations – the motor is to be switched off in case of doubt, the cause is to be evaluated and the manufacturer is to be contacted if required.</p>
---	---



3 Mounting

3.1 Safety notes

Before the mounting:

	<p>Never mount or take an defect electric motor into operation.</p> <p>Never install the electric motor in a defect machine.</p> <p>Make sure that the electric motor is appropriate for your machine before installing it.</p>
---	---

During the mounting:

	<p>Mount the motor to provided fastening options only.</p> <p>Avoid shocks or inadmissible shock loads during the mounting.</p> <p>Attach all covers and safety equipment. All the safety equipment must comply with the applicable regulations (e.g. EN 60204).</p> <p> Water cooling:</p> <p>In order to avoid damages of the housing screw-in glands with cylindrical internal thread may be used for the water connections (inlet / outlet), only.</p> <p>From cooling pipes tensile loads, compression loads and torsional loads may not be applied to the motor connections.</p> <p>The connection may only be executed by specialists. Thereby, the motor must be without current and voltage.</p> <p>It must be considered that the cooling liquid doesn't reach the motor terminal box when coupling and uncoupling the cooling cables.</p>
---	--

3.2 Installing, attaching

Check the following before and during mounting

- The motor must be intact (e.g. in no way the shaft seal may be damaged by sharp and pointed objects.).
- The motor may not be mounted within the danger range of other facilities.
- The intended use must be complied with (see **chapter 1.2 and 2.4**)
Observe the type plate specifications and warning and information signs
- The anticorrosive must be removed residue-free at the shaft end.
When using commercial resolvents such as acetone or cleaning solvent the shaft seal may not be wetted!
- The motor must comply with the environmental conditions and the environmental influences on-site (see **chapter 2.4**).
- The internal space in the machine must comply with the cooling type of the electric motor.
The motor must be installed to guarantee that the connection of cooling cables is possible.
- In order to connect the motor and to execute inspection and maintenance workings there must be sufficient space in the machine.
The mounting dimensions of the motor including the tolerance specifications can be taken from the technical documents or from the dimension drawing handed over.
- The motor must be able to be mounted and operated with the available connection data and the fastening options.
*When flanging to the motor a good and even contact area must be regarded. The guide fittings and contact areas must be undamaged and clean. They should be in the exact positioning to the shafts to be connected, to avoid harmful loads due to offset of the bearings, shafts and housings in the entire system. When tightening the flange screws (**at least strength class 8.8**) avoid distortions at the flange connection.*
- At a vertical assembly with the shaft end to the top assure that there is a protection against ingress of liquids onto the upper bearings.
- The permitted radial forces may not exceed the accordant performance characteristics of the technical documents of the product (if required clarify by a Baumüller subsidiary).
If there are axial forces this must be approved by the motor manufacturer.
- It must be possible to release the brake (optional) after applying the operating voltage (audible operating noise)
- The rotor must be able to turn uniformly and without chafing noise.
The brake must be released beforehand if the motor has an integrated brake.
- The version of the motor and encoder lines must comply with the technical documents of the product.
- The output elements as well as the drive elements must be protected.
- The complete cooling system must be sealed and functionally as well as protected against foreign objects that have fallen in.

3.3 Vibrations and resistance to vibrations

The vibration response of the entire system at the place of use, caused by output elements, mounting conditions, alignment and installation as well as by influences of external vibrations, can lead to an increase in the vibration values at the motor. Under certain circumstances a complete c balancing of the rotor with the output element becomes necessary.

In order to be able to guarantee perfect function and service life the specified vibration values based on DIN ISO 10816 must not be exceeded at the specified measuring points of the motor (refer to figure 1).

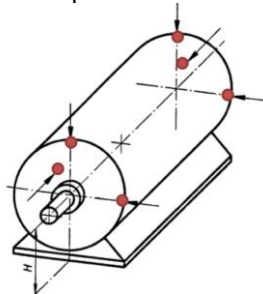

Figure 1: Measuring points for vibration measurement

The specified maximum radial and axial vibration values must be adhered to at the same time. They apply to substructures which can be described as elastic. An elastic substructure is present if the lowest natural frequency of the overall system (machine and base) in the measuring direction is at least 25% below the essential excitation frequency. All of the other substructures can be described as rigid. In case of rigid substructures, the manufacturer must be consulted.

Maximum radial vibration load:

Peak vibration acceleration	1 g	> 250 Hz
Peak vibration displacement	≤ 0.16 mm	< 6,3 Hz
Effect. vibration speed	≤ 4.5 mm/s	6.3 Hz – 250 Hz

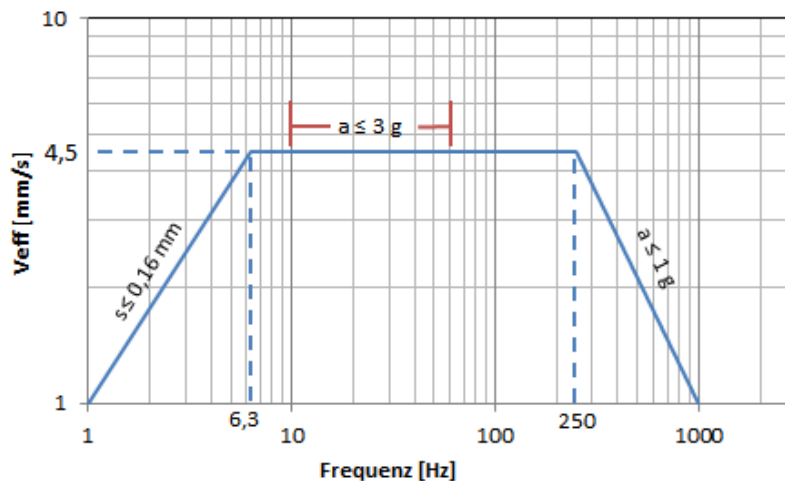

Figure 2: Permitted radial vibration load

Maximum axial vibration load:

Peak vibration acceleration	0.225 g	> 55 Hz
Peak vibration displacement	≤ 0.16 mm	< 6.3 Hz
Effect. vibration speed	≤ 4.5 mm/s	6.3 Hz – 55 Hz

Additional vibration resistance:

Vibration acceleration 3 g radial and 1g axial 10 Hz to 55 Hz

The specified vibrations are additionally endured by the motor. However, the service life of wear parts (such as bearings) can be reduced.

Shock load:

If there are increased vibration loads in the form of shocks, measurements on the installed machine are necessary.

Based on this, constructive revisions and evaluations are carried out with the company Baumüller.

To evaluate the vibration speed, the measuring equipment shall meet the requirements of ISO 2954. The vibration acceleration shall be evaluated in the time range in the frequency band from 10 Hz to 2 kHz.

If significant vibration excitations above 2 kHz are to be expected, such as meshing frequencies, the measuring range must be adapted accordingly. The permissible maximum values thereby do not change.



3.4 Electric connection

Important notes:

	<p>All works must be processed by qualified specialists, only.</p> <p>All works must be processed at the de-energized and provide a safeguard to prevent unintentional reclosing (auxiliary circuits as well).</p> <p>All works must be processed at motor standstill, only. When having three phase synchronous motors with permanent-magnet excitation voltages that are > 60 V can occur at the motor terminals at a rotating rotor.</p> <p>Comply with the regulations for works on electrical systems!</p>
---	--

Attention! It must be complied with the safety regulations for works in electrical engineering systems according to EN 50110-1:

- Disable
- Provide a safeguard to prevent unintentional reclosing
- Verification of safe isolation from supply
- Grounding and short-circuiting
- Cover or safeguard adjacent live parts

	<p>The operation of the electric motor is permissible with an accordantly configured converter. The direct connection to the three-phase system can cause the destruction of the motor.</p> <p>Pay attention to the correct phase sequence and the connection assignment!</p>
	<p>The electric connections, protective conductor connections and shield connections (when using screened cables) must be designed permanently safe!</p> <p>Never touch the contacts of the encoders and temperature sensors with your hands or with tools which are loaded electrostatically. Encoders and temperature sensors are electrostatic sensitive devices.</p>

Electric installation:

- The constructor is responsible for the proper installation of the system.
- The motor data on the type plate must be considered.
- Connection cables and connectors must be calculated correctly for the occurring voltages and current and must be suited for the installation type.
- The motor connection including its modules (brake, encoder, etc.) must be made according to the specifications of the connection diagrams (see enclosed connection diagrams and **Appendix 1**)
- To avoid electromagnetic EMC troubles of supply cables and the consequences thereof on the encoder and control systems shielded power and encoder cables are to be used. Please, observe the EMC notes of the converter manufacturer.

- For reasons of operational safety Baumüller recommends to use their preassembled connection cable connections.
- Before the connection the receptacle boxes, the connector as well as the terminal box must be checked for damage, corrosion, dirt and humidity.
- To guarantee the degree of protection the correct and tight fit of the connector screw fittings, the seals and the sealing surfaces of the connectors and of the terminal boxes must be observed. **Note!** The rotatable outlet boxes shouldn't be turned more than five times towards their connecting direction to observe the degree of protection as well.
- Plug and terminal box connections must not be exposed to mechanical stress. If required apply anti-rotation, strain and thrust reliefs as well as a bend protection.

Please, pay attention to the following at the main connection via the terminal box:

- The cable ends must be stripped so far as the isolation nearly reaches the cable lugs and terminals. . Protuding wiring ends must be avoided, absolutely.
- The cable lugs must be matched to the measurements and cross sections of the terminals and cables.
- The screw connections of the electrical connection must be tightened by the specified tightening torque. (see **Appendix 1 Table 6**)
- The degree of protection remains

Note: All inlets which are not required must be closed with metallic fastening elements. The sealing elements of the terminal box must be functional and undamaged.



4 Commissioning, operation

4.1 Safety notes

Workings at the electric motor:

	<p>Perform all workings at the electric motor only if the motor is at a standstill, free from tension and cooled off. All connections that were loosened during the workings at the motor must be fastened again before commissioning.</p> <p>Please, pay attention to the technical notes in the accordant chapters of this commissioning and maintenance instruction.</p> <p>Attention! The optional holding brake may not take over safety functions during the works at the motor (e.g. the holding of loads).</p>
---	---



Danger to life by electrical current:

 	<p>Assure that the electric motor released and without tension.</p> <p>Never loosen the connections at the motor during operation.</p> <p>Connect measuring devices in the de-energized and off circuit state, only</p> <p>Start the works at the motor connections after you assured that neither potential nor voltage is existent.</p> <p>During operation there is electrical potential at the motor terminals/motor contacts and at the motor windings. Never touch these modules / elements during the operation.</p>
--	---

Mounting and demounting of safety equipment:

	<p>The electric motor may not be operated without safety equipment.</p> <p>In order to mount or demount components and systems that are intended to monitor the safe motor operation the motor must be shutdown.</p>
---	--

Danger! Do not touch!

 	<p>Assure that the electric motor is at standstill and protected against being switched on before you touch it.</p> <p>The output shaft may only be touched if without tension and the motor is at standstill. Otherwise danger caused by the rotating rotor.</p> <p>Risk of burns! Never touch the motor housing during the rated load operation. The surface temperatures of over 70°C can arise at the motors</p>
--	--

4.2 Tests before commissioning

- The drive is undamaged and is within the range of other equipment.
- The motor was properly aligned and tightened. The screws are fastened correctly. Unused connection threads must be closed at the flange Connecting thread which are not required are to be sealed at the flange bearing end shield.
- All the associated protective equipment is to be mounted (mechanical, thermal, electrical).
- The motor connections were processed correctly.
- The ground conductor system was processed correctly and was tested for functioning.
- The cables do not touch the motor surface.
- The drive doesn't block (release brake where applicable).
- EMERGENCY OFF functions were checked
- The coolant lines were properly processed and the water cooling was tested for functioning.
- The fan is correctly connected and the functioning was checked.

4.3 Commissioning, operation

Notes regarding the functioning of the brake (where applicable):

	The brake is a holding brake including an emergency stop function. (power failure, emergency stop) Don't use the brake as a working brake.
---	---

Commissioning must be processed by qualified personnel, only.

Thereby, the commissioning instructions of the converter and of the cooling installation must be observed.

Tests during commissioning:



- Have all modules of the motor such as the encoder, the brake, the cooling and so on been tested on functioning and are all application conditions observed. Release brake as appropriate.
- Have all electrical connections and terminals been properly completed and fastened (observe connection diagrams / **Appendix 1 and enclosed connection diagrams**)
- Have all protective measures been met and is it operating correctly which excludes the touching of energized parts, hot surfaces, rotating and moving parts and modules.
- Were all output elements mounted and set complying with the specifications of the manufacturer.
- Is ensured that the maximum permitted speed n_{max} of the motor cannot be exceeded. The maximum permitted speed n_{max} is the highest short-term permissible operating speed.

Tests during operation:

- Pay attention to unusual noises.
- If scratching and scraping noises, grinding noises or the like occur shut down the drive immediately and find out the causes.
- Check the motor surface and connection lines for pollutions for example dust deposits, oil pollution, humidity, leakage etc.
- Check the maintenance intervals
- Check the air inlets and the air outlets for pollutions.

4.4 Failures

Safety notes:

	The error detection and the troubleshooting made be executed by qualified personell only.
	Don't take the protective equipment out of operation – neither in the testing operation.
	Demount the cooling lines in the unpressurized state
	The connection lines must be deenergized and in a safe state to loosen and mount them.
	Observe the five safety regulations regarding “release” (see chapter 3.4).
	Pay attention to hot surfaces!

Observe to the following at failures

- Observe the operation instruction of the machine/installation
- Observe the operation instruction of the converter
- If required contact the manufacturer of the motor or converter

Keep the following parameters ready:

Type plate data
 Type and extent of the failure
 Surrounding circumstances of the failure
 Application data (cycle of torque; speed and forces via the time, environmental conditions)

The following list could help in case of failures (**Table 5**):

Failure	Error cause	Correction
Motor doesn't start	Controller release is missing	Activate controller release
	Controller–error, encoder-error	Error listing at the converter or read the controller, correct the error
	Voltage supply is missing	Check connection and voltage supply
	Rotating field	Check phase sequence and exchange connection line if needed
	Brake doesn't release	Check control, connection and voltage supply
Irregular running	Brake defect	Repair by the manufacturer
	Shielding in the connection lines is insufficient	Check shield connection and grounding
Vibrations	Controller parameter too high	Optimize controller parameters
	Coupling elements or driven machines were incorrectly balanced	Rebalance
	Incorrect alignment of the powertrain control	Realign machine set
	Fastening screws are lose	Check screw connections and fasten them

Failure	Error cause	Correction
Running noises	Foreign particles in the motor	Repair by manufacturer
	Bearing damage	Repair by manufacturer
Motor warms up too much Motor temperature monitoring responds	Drive overload Water cooling inactive. Cooling supply insufficient - Filter is very dirty - Deposits in the cooling channels - Failures in the external cooling system Insufficient release of the brake – grinding brake	Check motor load and compare it with the type plate data Check and switch on if required Check water circuit - Check and clean if required - Check and clean if required - Refer to notes of the plant manufacturer Repair by motor manufacturer
Overpressure in the cooling system	Strongly polluted coolant Cooling channels blocked Failures in the external cooling system	Filter the coolant Check and clean if required Refer to notes of the plant manufacturer
Current input too high, motor torque too low	Notch position incorrect	Check notch position and set if required

Table 5 : Operating faults

5 Inspection and maintenance

Works at the electric motor:

	<p>Execute the works at the electric motor only if the motor is at standstill, de-energized and has cooled off. Fasten all loose connections such as screws, cables etc. after the inspection or maintenance again.</p> <p>Observe the technical notes in the accordant chapters of this commissioning and maintenance instruction in the works.</p> <p>Observe the safety notes during the maintenance works, which are the same as for the commissioning of the motor (see Chapter 4.1).</p> <p>Attention! If there is an optional holding brake it may not take up a safety function (e.g. holding of loads).</p>
---	--

5.1 Inspection

Accordant to the local degree of pollution regular cleaning must be made to ensure a permanent adequate dissipation of the heat loss. Thereby, the volume rate and the pressure ratio of the cooling system must be checked.

If a brake was optionally installed then the wear limits must be specified (e.g. maximum permitted operating air gap, limited number of emergency brakings). The current wear degree of the brake is to be checked regularly. When reaching the permitted wear limits the brake is to be exchanged (see **Chapter 5.2**).

If, optionally a shaft sealing ring is used this must be checked regularly for its proper functioning (leakage).

5.2 Maintenance

Dependent of the operating conditions (such as operation mode, temperature, speed load, mounting position) very different times of service life can be referring to the lubricants, sealing elements and bearing locations.

We recommend the following maintenance guide values at a fault-free operation:

- Change the bearing after approximately 20000 operating hours (the bearings reach a storage service life of 10 of 20000 operating hours). Exceptions must be defined separately (e.g. lubrication).
- The changing of the **shaft seal** is made after about 5.000 operating hours, if applicable and if no leakage was determined prior to that.

If a **brake** was built in optionally, it is essential to exchange it, if the wear limit was reached.

Maintenance works must be executed by Baumüller or by a specialized company that was assigned by Baumüller.

The following independent maintenance work is to be done by the operating company:

- The cleaning of the motor surfaces and of the air channels.
- The changing or cleaning of the filter mats when using dust filters

Normally, **dust filters** should be cleaned or exchanged after 100 operating hours. If the soiling is very high the maintenance intervals are to be reduced.

Dry-soiled filters can be cleaned by suction, air-cleaning or by tapping off. Moisty soiled filters can be rinsed in lukewarm water by adding commercial detergents and then be dried.

Note: When exchanging the filter mats the original replacement filters of the motor manufacturer should be used. These can be obtained at Baumüller's by specifying the motor or part number (see type plate).

Attention!

It is essential when using motors in safety-related applications to comply with the technical instruction TAM 00687 during maintenance and service.

6 Disposal

The motor must be disposed in the normal recyclable material process by complying with the national and local regulations.

Attention: The rotor of the DS2 motors contain rare-earth magnets with high magnetical energy density. See note in **Chapter 1.2**.

The encoder electronics (if available) must be disposed of correctly as electronic waste.

7 Appendix 1: Pole assignments (power and control connections)

7.1 Main connection via terminal box

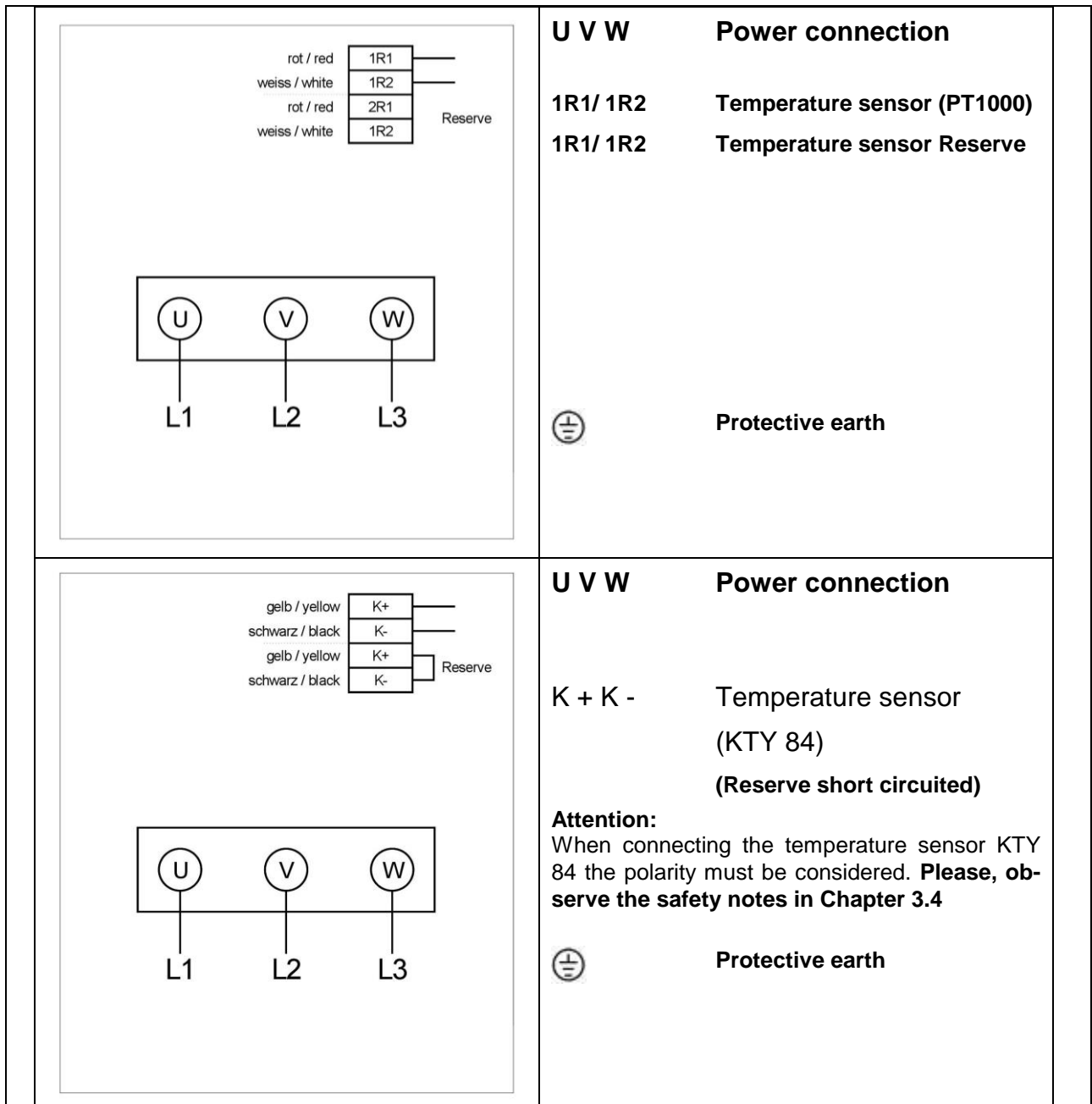

Figure 3: Main connection with terminal box

We recommend to use EMC screw connections at the fittings for the cable entries.

While tightening the clamping screw we recommend to hold up at the conductor to avoid a deformation of the mounting rail and to keep the base of the terminal free of torsional forces.

The following terminal box versions for the terminals are available including the tightening torques which are to be complied with (Table 6):

Motor size	Cable entry	Number of main connection terminals	Tightening torques of terminals in Nm
100	2 x M 25x1,5	3 x M 8	6,0
	1 x M 40x1,5 + 1 x M 25x1,5		
	1 x M 63x1,5 + 1 x M 25x1,5		
132	3 x M 25x1,5	3 x M 8	6,0
	2 x M 40x1,5 + 1 x M 25x1,5		
	2 x M 63x1,5 + 1 x M 25x1,5		
	2 x M 63x1,5 + 1 x M 25x1,5	3 x M 10	10,0
160	2 x Ø 40,5 + 1 x Ø 25,5	3 x M 6	3,0
	2 x Ø 64 + 1 x Ø 25,5	3 x M 10	10,0
	2 x Ø 76 ¹⁾ + 1 x Ø 25,5	3 x M 12	15,5
200	1 x Ø 64 + 1 x Ø 25,5	3 x M 10	10,0
	2 x Ø 64 + 1 x Ø 25,5	3 x M 10	10,0
	2 x Ø 76 ¹⁾ + 1 x Ø 25,5	3 x M 12	15,5
	6 x Ø 51 + 1 x Ø 25,5 + 2 x Ø 40,5	3 x M 16	30,0

Table 6: Terminal box versions with tightening torques for nuts

¹⁾ Cable shield led with the cable lug on the housing into the terminal box

7.2 Control connection: Resolver

	Pin	Signal
 <p>View on the contact side of the mounting box</p>	1	cos -
	2	
	3	
	4	
	5	sin -
	6	sin +
	7	
	8	cos +
	9	
	10	Ref +
	11	
	12	Ref -

Figure 4: Pole assignment resolver

7.3 Control connection : SRS / SRM 50

(absolute value encoder with hipurface interface of the company SICK / Stegmann)

	Pin	Signal
 <p>View on the contact side of the mounting box</p>	1	ref cos
	2	+ 485
	3	
	4	
	5	sin
	6	ref sin
	7	- 485
	8	cos
	9	Shield
	10	Gnd
	11	
	12	+ U

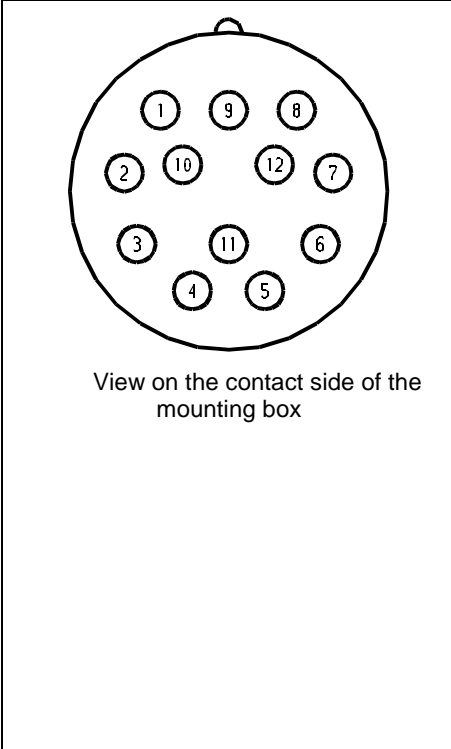
Figure 5: Pole assignment SRS / SRM 50

7.4 Control connection : ECN 1313 / EQN 1325

(absolute value encoder with Endat 2.1-interface of the company Heidenhain)

	Pin	Signal
 <p data-bbox="384 680 719 734">View on the contact side of the mounting box</p>	1	U _p
	2	
	3	
	4	0V
	5	
	6	
	7	U _p
	8	Clock
	9	Clock inv.
	10	0V
	11	
	12	B+
	13	B-
	14	Data
	15	A+
	16	A-
		17

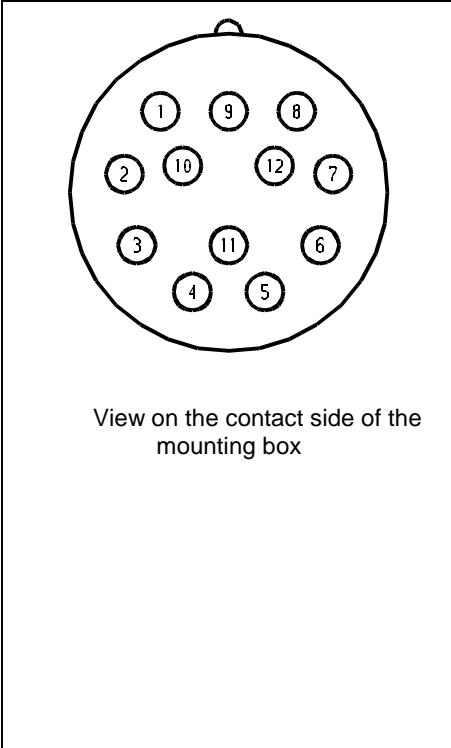
Figure 6: Pole assignment ECN 1313 / EQN 1325

7.5 Control connection : ECN 1325 / EQN 1337

(absolute value encoder with Endat 2.2-interface of the company Heidenhain)

 <p>View on the contact side of the mounting box (M23)</p>	Pin	Signal
	1	Clock
2	Clock inv.	
3	Up	
4	0 V	
5	Data	
6	Data inv.	
7	Sensor Up	
8	Sensor 0 V	
9	-	

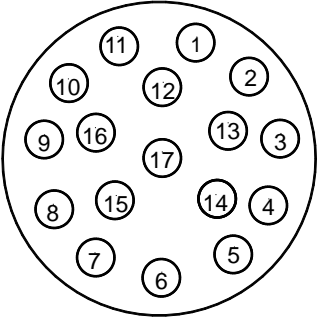
Figure 7: Pole assignment ECN 1325 / EQN 1337 (M23)

Note:

- Please, take the pole assignment from the accordingly enclosed connection diagrams or from the technical documents concerning encoder types which were not mentioned here and at an optional cable of the temperature sensor via the encoder cable.
- The encoders mentioned from **point 7.3 to 7.5** are ESD-sensitive devices.
- The specifications of the technical data were provided by the encoder manufacturer and we assume no liability for its correctness.

7.6 Fan connection / terminal markings

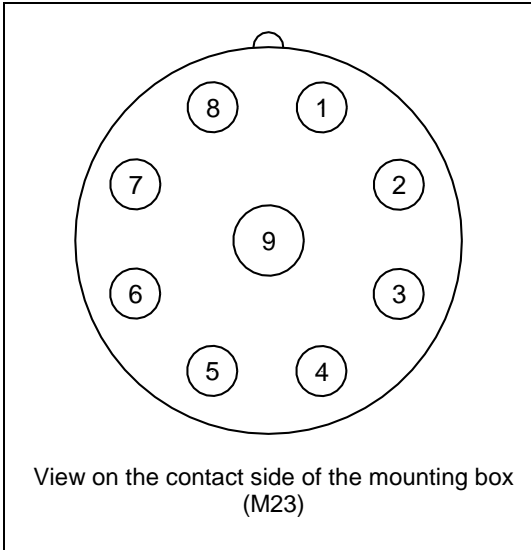
Fan connection at the standard fan motor via the terminal box	Fan connection at the installed fan motor																																														
<p>Connection diagram</p>  <p>U V W Power connection</p>	<p>Connection diagram</p>  <table border="1" data-bbox="874 577 1225 739"> <tr> <td>Pin</td> <td>1</td> <td>2</td> <td>4</td> <td>5</td> </tr> <tr> <td>Signal</td> <td>V</td> <td>W</td> <td>/</td> <td>U</td> </tr> <tr> <td>Pin</td> <td>6</td> <td>⊥</td> <td></td> <td></td> </tr> <tr> <td>Signal</td> <td>/</td> <td>⊥</td> <td></td> <td></td> </tr> </table> <p>Acceptable for field wiring</p> <p>Connection diagram: Fan-Motor 6 - pole box</p> <p>KA 207i1u 09.10.08 Be</p>	Pin	1	2	4	5	Signal	V	W	/	U	Pin	6	⊥			Signal	/	⊥																												
Pin	1	2	4	5																																											
Signal	V	W	/	U																																											
Pin	6	⊥																																													
Signal	/	⊥																																													
<p>Axially added-on standard fan</p> <table border="1" data-bbox="204 891 810 1198"> <thead> <tr> <th rowspan="2">Size</th> <th colspan="3">Rated current in A at Δ/Y:</th> </tr> <tr> <th>Standard 200-265 V 50 Hz 345-460 V 60 Hz</th> <th>265-345 V 50 Hz 460-600 V 60 Hz</th> <th>UL approved 240-420 V 50 Hz 280-480 V 60 Hz</th> </tr> </thead> <tbody> <tr> <td rowspan="2">132</td> <td>0,57</td> <td>0,45</td> <td>0,48</td> </tr> <tr> <td>0,33</td> <td>0,26</td> <td>0,28</td> </tr> <tr> <td rowspan="2">160</td> <td>1,4</td> <td>1,1</td> <td>1,07</td> </tr> <tr> <td>0,8</td> <td>0,6</td> <td>0,62</td> </tr> <tr> <td rowspan="2">200</td> <td>2,4</td> <td>2,25</td> <td>1,8</td> </tr> <tr> <td>1,4</td> <td>1,3</td> <td>1,05</td> </tr> </tbody> </table> <p>The rated currents are maximum values.</p>	Size	Rated current in A at Δ/Y:			Standard 200-265 V 50 Hz 345-460 V 60 Hz	265-345 V 50 Hz 460-600 V 60 Hz	UL approved 240-420 V 50 Hz 280-480 V 60 Hz	132	0,57	0,45	0,48	0,33	0,26	0,28	160	1,4	1,1	1,07	0,8	0,6	0,62	200	2,4	2,25	1,8	1,4	1,3	1,05	<p>Axially added-on fan motor</p> <table border="1" data-bbox="898 891 1316 1048"> <thead> <tr> <th rowspan="2">Size</th> <th colspan="2">Rated current in A at Y:</th> </tr> <tr> <th>400 V 50 Hz</th> <th>460 V 60 Hz</th> </tr> </thead> <tbody> <tr> <td>160</td> <td>0,7</td> <td>0,75</td> </tr> </tbody> </table> <p>The rated currents are maximum values</p>	Size	Rated current in A at Y:		400 V 50 Hz	460 V 60 Hz	160	0,7	0,75										
Size		Rated current in A at Δ/Y:																																													
	Standard 200-265 V 50 Hz 345-460 V 60 Hz	265-345 V 50 Hz 460-600 V 60 Hz	UL approved 240-420 V 50 Hz 280-480 V 60 Hz																																												
132	0,57	0,45	0,48																																												
	0,33	0,26	0,28																																												
160	1,4	1,1	1,07																																												
	0,8	0,6	0,62																																												
200	2,4	2,25	1,8																																												
	1,4	1,3	1,05																																												
Size	Rated current in A at Y:																																														
	400 V 50 Hz	460 V 60 Hz																																													
160	0,7	0,75																																													
<p>Radially added-on standard fan motor</p> <table border="1" data-bbox="204 1339 810 1892"> <thead> <tr> <th rowspan="2">Size</th> <th colspan="3">Rated current in A at Δ/Y:</th> </tr> <tr> <th>Standard 200-265 V 50 Hz 345-460 V 60 Hz</th> <th>265-345 V 50 Hz 460-600 V 60 Hz</th> <th>UL approved 240-420 V 50 Hz 280-480 V 60 Hz</th> </tr> </thead> <tbody> <tr> <td rowspan="2">100</td> <td>0,57</td> <td>0,45</td> <td>0,48</td> </tr> <tr> <td>0,33</td> <td>0,26</td> <td>0,28</td> </tr> <tr> <td rowspan="2">132</td> <td>1,4</td> <td>1,1</td> <td>1,07</td> </tr> <tr> <td>0,8</td> <td>0,6</td> <td>0,62</td> </tr> <tr> <td rowspan="2">160</td> <td>2,4</td> <td>2,25</td> <td>1,8</td> </tr> <tr> <td>1,4</td> <td>1,3</td> <td>1,05</td> </tr> <tr> <td rowspan="2">200</td> <td>-</td> <td>-</td> <td>3,7</td> </tr> <tr> <td></td> <td></td> <td>2,15</td> </tr> <tr> <td></td> <td>230-400 V 50 Hz 280-480 V 60 Hz</td> <td>-</td> <td>-</td> </tr> <tr> <td rowspan="2">200</td> <td>5,5</td> <td></td> <td></td> </tr> <tr> <td>3,2</td> <td></td> <td></td> </tr> </tbody> </table> <p>The rated currents are maximum values.</p>	Size	Rated current in A at Δ/Y:			Standard 200-265 V 50 Hz 345-460 V 60 Hz	265-345 V 50 Hz 460-600 V 60 Hz	UL approved 240-420 V 50 Hz 280-480 V 60 Hz	100	0,57	0,45	0,48	0,33	0,26	0,28	132	1,4	1,1	1,07	0,8	0,6	0,62	160	2,4	2,25	1,8	1,4	1,3	1,05	200	-	-	3,7			2,15		230-400 V 50 Hz 280-480 V 60 Hz	-	-	200	5,5			3,2			
Size		Rated current in A at Δ/Y:																																													
	Standard 200-265 V 50 Hz 345-460 V 60 Hz	265-345 V 50 Hz 460-600 V 60 Hz	UL approved 240-420 V 50 Hz 280-480 V 60 Hz																																												
100	0,57	0,45	0,48																																												
	0,33	0,26	0,28																																												
132	1,4	1,1	1,07																																												
	0,8	0,6	0,62																																												
160	2,4	2,25	1,8																																												
	1,4	1,3	1,05																																												
200	-	-	3,7																																												
			2,15																																												
	230-400 V 50 Hz 280-480 V 60 Hz	-	-																																												
200	5,5																																														
	3,2																																														

Table 7: Data fan connection

8 Anhang 2: Water cooling

Additionally to the preceding chapters the following must be observed at water-cooled motors (EN 60034-6; IC 3W7):

8.1 Specifications referring to the required cooling flows

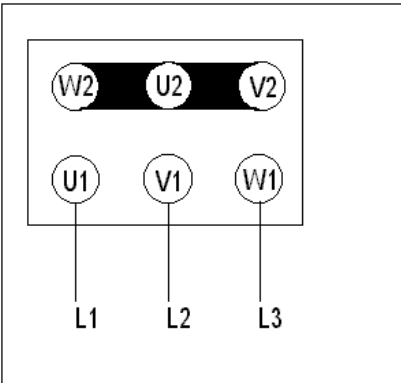
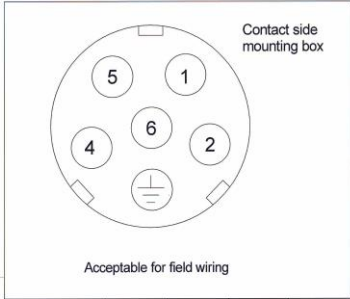
Motor type	Volume current [l/min]	Pressure drop $\pm 15\%$ [bar]	Heating [K]	Max. coolant pressure [bar]	Connection (G –inside thread)
DS2-100KO	7	0,4	4	6	2 x G 1/2" 1x forward motion 1x return motion
DS2-100MO			5		
DS2-100LO			6		
DS2-100BO			7		
DS2-132KO	9	0,25	4	6	2 x G 1/2" 1x forward motion 1x return motion
DS2-132MO			5		
DS2-132LO			6		
DS2-132BO			7		
DS2-160KO	10	0,45	5	6	4 x G 1/4" 2x forward motion 2x return motion
DS2-160MO		0,5	6		
DS2-160LO		0,55	7		
DS2-160BO		0,6	8		
DS2-200KO	13	1,3	5	6	4 x G 1/4" 2x forward motion 2x return motion
DS2-200MO		1,45	7		
DS2-200LO		1,6	8		

Table 8: Required cooling volume flows

8.2 Media-contacting materials in the motor

The following media-contacting materials are used in the motor:

Size 100-132:

Cooling system: Aluminium KTL coatet

Connections: Steel zinc-plated

Seals: NBR

Size 160-200:

Cooling system: Stainless steel

Connections: Brass

Seals: Vulcanized fibre

8.3 Motor cooling

Additions of corrosion and nucleation protections may be used in closed cooling systems performed accordingly to the coolant's characteristic complying with **Chapter 8.6**. Type and quantity is based upon the accordant recommendations of the manufacturer and of the prevailing environmental conditions.

	<p>The safety regulations of the accordant corrosion and nucleation protection manufacturer must be observed.</p> <p>Coolants from operating processes may not be used to cool the motor!</p> <p>In view of harmful deposits the filling of a closed cooling system should be made in the cooling channels or cables using filtering at all times (filtering resolution < 0,1 mm). At the open cooling system in any case a filtering must be provided.</p>
---	--

Note: The system manufacturer is responsible for the engineering of the entire cooling system.
Condensation of water must be avoided in any case.

8.4 Mounting notes

	<p>Cooling system connection:</p> <p>On the motor connections from the coolant pipes no tensile loads, thrust loads or torsional stress may be applied.</p> <p>The connection may be executed by specialists only. Thereby the motor must be currentless and without tension.</p> <p>When coupling or decoupling the coolant pipes it must be observed that no cooling liquid gets into the motor terminal box.</p>
---	--

	<p>Sealing test complying with EN 50178:</p> <p>The sealing of the cooling system must be tested before commissioning by a pressure-test with the coolant (water). The testing pressure must be twice the operating pressure. (Minimum test pressure 1 bar). The used coolant must thereby not be brought to the operating temperature. The pressure must be maintained. (Minimum testing time 10 minutes).</p>
---	--

8.5 Electrical connection

The power connection is made in the water-cooled motors compliant with the dimension drawing in the technical documentation.

8.6 Cooling water status

The cooling water must comply with the following requirements:

Conditions	Unit	Value
Permitted system pressure at maximum	bar	6
Temperature of coolant for motor	°C	10 to 25
pH-value (bei 20 °C)	---	6,5 to 9
Total hardness	mmol / l	1,43 to 2,5
Chloride - Cl	mg / l	< 200
Sulfate - SO ₄ ²⁻	mg / l	< 200
Oil	mg / l	< 1
Permissible particle size, solid bodies, particles (e.g. sand)	mm	< 0,1

Table 9: Cooling water status

As a coolant, water, which is clear and free of suspended solids and free of soiling is to be used.

8.7 Minimum coolant temperature in dependence of the environmental conditions.

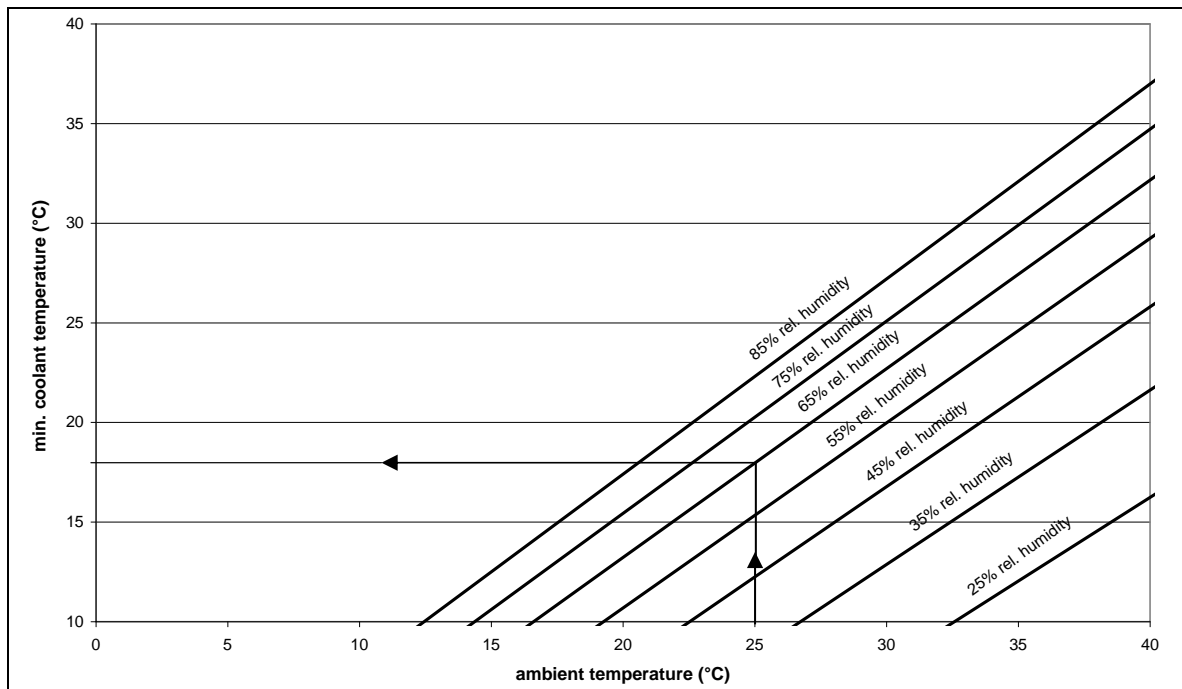

Figure 8: Evaluation of coolant temperature

The permitted temperature of the coolant is dependent of the relative humidity during the operation and the environmental temperature. For example a minimum coolant entry temperature of 18°C is permitted at an environmental temperature of 25°C and a relative humidity of 65%. The presented characteristics in the diagrams are limit characteristics. Therefore, in the example a coolant entry temperature of greater 18°C should be selected.

If the minimum permitted coolant entry temperature is fallen below, the 2-point controller of the Baumüller drive electronics must be used, to avoid condensation (see displayed function chart – **Figure 9**).

Note:

At a longer standstill of the motor the coolant supply must be interrupted (avoidance of condensation).

At a longer standstill environmental temperatures <3 °C can occur, the coolant is to be drained as a precautionary measure. (Avoidance of frost damage).

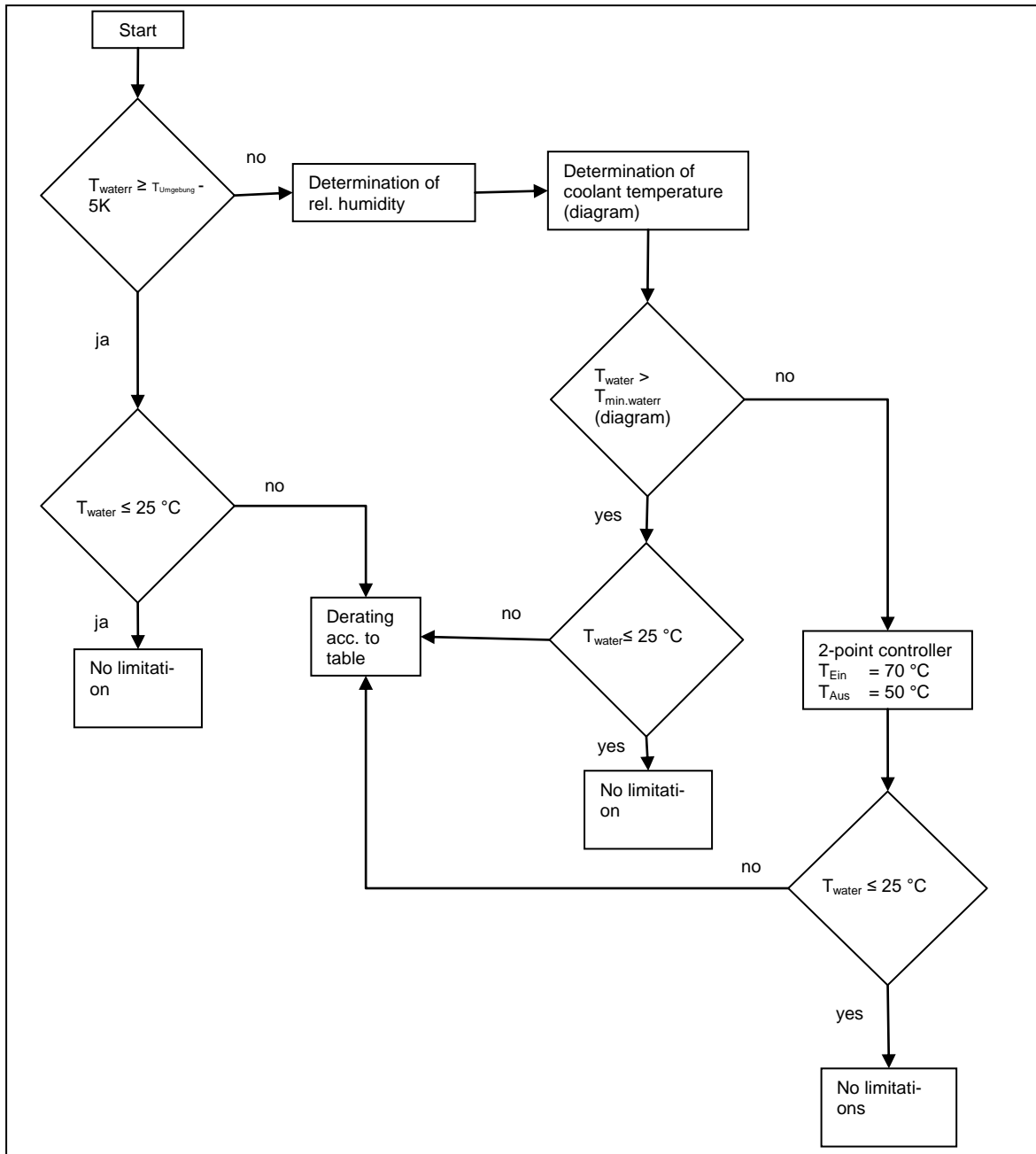

Figure 7: Function chart coolant entry temperature

8.8 Failures

Failure	Cause of failure	Correction
Overtemperature in the motor Motor temperature monitoring responses	Water cooling is not active Coolant supply insufficient - Deposits in the cooling channels - Failures in the external cooling system -	Check and switch on if required Check water circuit - Check and clean if required - Notes provided by the installation manufacturer
Overpressure in the cooling system	Coolant is heavily soiled Cooling channels are blocked up Failures in the external cooling system	Filter coolant Check and clean if required Notes provided by the installation manufacturer

Table 10: Operating failures water cooling

8.9 Inspection

The pressure ratio of the cooling system and the volume current must be checked during the regular cleaning.

Warranty and liability

All data/information in this documentation are non-binding customer information, subject to constant further development and are constantly updated by our permanent modification service. Warranty and liability claims against the company Baumüller Nürnberg GmbH are excluded if in particular one or more of the following causes have caused the damage:

- You disregarded instructions in this documentation.
- The system wasn't used for the intended use.
- The system
 - o was incorrectly mounted, connected, put into operation, operated as well as not maintained,
 - o was mounted, connected, put into operation, and operated and / or maintained by unqualified personnel,
 - o is overloaded,
 - is operated with
 - o defective safety equipment,
 - o not properly fixed or without safety equipment,
 - o not functioning safety and protective equipment.
 - Isn't operated within the specified environmental conditions.
- You modified the system without having a written approval of the company Baumüller Nürnberg.
- You disregarded the instructions referring to the maintenance in the component descriptions.
- You monitored the parts, which are subject to wear, inadequately.
- You performed a repair incorrectly.
- You combined the system incorrectly with products of other manufacturers.
- You combined the drive system with faulty and / or faulty documented products of other manufacturers.

The latest version of the "Terms and Conditions of Sale and Delivery" of the company Baumüller Nürnberg GmbH applies.

These were provided at the latest upon conclusion of contract.

Change

Compared to TAM00713 version 10/2019, the following has been corrected.

Page 25 ; table 6 : Motor size 100

1x M25x1,5+1x M25x1,5 in 1x M40x1,5+1x M25x1,5