

be in motion be in motion

**Commissioning and
Maintenance Instructions**

TAM 00616

DS 100 – 200 W

Three-phase synchronous motor
Water-cooled

Version: 10 / 2004
English

LEGAL NOTES ON DOCUMENTATION

Copyright

This documentation is only permitted to be copied by the owner for internal use. As many copies as required may be made. For other purposes, this documentation may not be copied or duplicated either in whole or in part. Utilisation and provision of the contents to third parties is not allowed. Names and company logos in this documentation may be trademarks, which, if used by third parties for their own purposes, may result in infringements of the rights of the owner.

Applicability

This documentation is part of the unit/the machine. These Commissioning and Maintenance Instructions must be available to the operator at all times and be in a readable condition.

On the sale/storage of the unit/machine, this documentation must be passed on together with the unit/machine by the owner. Following the sale of the unit/machine, this original and all copies are to be passed on to the purchaser. Following disposal or any other form of termination of utilisation, this original and all copies are to be destroyed.

With the introduction of this documentation, earlier issues of are superseded.

Please note that the details/figures/information represent **current values at the time of going to press**. These details are **not legally binding** for the purpose dimensioning, computation and calculation.

Baumüller Nürnberg GmbH reserves the right to change the technical data and the method of operation of Baumüller products in the context of the further development of the products.

No liability can be accepted concerning the correctness of the product information unless otherwise specified in the General Conditions of Sale and Delivery.

BAUMÜLLER NÜRNBERG GmbH
Motor Division
D-90482 Nuremberg

Table of contents

| | |
|--|-----------|
| 1. General Safety Instructions | 4 |
| 1.1 Safety..... | 4 |
| 1.2 Designated use..... | 5 |
| 1.3 Prohibition of unauthorised modifications and changes..... | 6 |
| 2 Operating conditions | 7 |
| 2.1 Product description | 7 |
| 2.2 Scope of supplies..... | 7 |
| 2.3 Nameplate..... | 7 |
| 2.4 Technical data | 8 |
| 2.5 Transport, intermediate storage..... | 9 |
| 2.6 Installation conditions, cooling details..... | 9 |
| 2.7 Balancing, drive elements and vibration..... | 10 |
| 3 Mounting | 11 |
| 3.1 Safety instructions..... | 11 |
| 3.2 Installation, fixing..... | 12 |
| 3.3 Electrical connections..... | 13 |
| 4 Commissioning, operation | 14 |
| 4.1 Safety instructions..... | 14 |
| 4.2 Checks prior to commissioning..... | 15 |
| 4.3 Commissioning, operation | 15 |
| 4.4 Malfunctions..... | 16 |
| 5 Inspection and maintenance | 18 |
| 5.1 Inspection..... | 18 |
| 5.2 Maintenance | 18 |
| 6 Disposal | 18 |
| 7 Appendix 1 | 19 |
| 8 Appendix 2 | 21 |

1. General Safety Instructions

1.1 Safety

This electric motor has been constructed in accordance with the relevant safety standards and underwent an operational safety check before leaving our factory.

To ensure correct commissioning and safe utilisation, please read the following:

- these Commissioning and Maintenance Instructions
- the enclosed safety and commissioning notes
- the technical documentation that accompanies the product
- the commissioning and safety notes provided by the manufacturer of the converter
- the national, local and system-specific regulations concerning your finished product.

We draw your attention to the following hazards when using the product:

- Hazards resulting from
- lifting and transport processes
 - electrical current
 - moving parts
 - hot surfaces
 - EMC disturbances
 - mechanical overloads
 - thermal overload

To avoid damages to persons and property and minimize residual risks, please read all of the safety instructions and, in particular, those that are marked with a symbol.



Danger to life through electrical shock

Non-observance can lead to death or a grave injury.



Warning concerning general dangers

Non-observance can lead to serious injury or damage to material assets.



Warning concerning dangerous situation

Non-observance can lead to damage of system or peripheral equipment.



Do not touch!

Non-observance can lead to serious injury.



Unpermitted action

Non-observance can lead to serious injury.



Warning concerning hot surface

Non-observance can lead to serious injury.



Electrostatically sensitive components

Non-observance can cause damage to the plant or the environment.

1.2 Designated use

The electric motor must only be used for its designated purpose. In this context, the electric motor must only be used for the applications described in this technical documentation under strict observance of all the notes in these Commissioning and Maintenance Instructions.

All assembly, commissioning, maintenance and operating tasks must be carried out by qualified personnel only.

Within the context of these safety instructions, qualified personnel refers to persons who are trained and authorized in the specialized area, who are authorized to set up, assemble, commission and operate devices, systems and circuits under application of the applicable safety standards (in accordance with IEC 364 / DIN VDE 0105).

Inappropriate action can cause serious damage to persons and property.

The electric motor is designed for use in industrial applications and is subject to the following standards and directives:

Standards

EN 60034-1, EN 60034-5, EN 60034-6, EN 60034-7, EN 60034-9, EN 60204-1

Low Voltage Directive 73/23/EEC

The electric motors in this series fully comply with the requirements of the Low Voltage Directive 73/23/EWG (Conformity).

Machinery Directive 98/37/EC

Electric motors and components for installation in machines in the sense of the Machinery Directive. Commissioning is not permitted until such time as the conformity of the finished product with this directive has been established (refer to EN 60204-1 "Electrical Equipment of Machines").

EMC Directive 89/336/EEC

The operation of the electric motor for its designated use must comply with the protective requirements laid down in the EMC Directive 89/336/EEC. The person setting up the system is responsible for the correct installation (e.g. spatial isolation of signal lines and power cables, screened lines and cables etc.). In the case of systems with converters, the EMC notes of the manufacturer of the converter must also be observed.

All national, local and system-specific regulations must also be observed!

The electric motor is designed for the following ambient conditions:

- Ambient temperature: 0 °C to +40 °C
- Installation height: ≤1,000 m a.m.s.l.
- Relative humidity: 10 % to 80 %

Condensation water must not be allowed to accumulate.

Measures to protect against the accumulation of condensation water during water cooling (**comp. Appendix 2**):

- Inlet temperature (coolant) = ambient temperature.
- In moderate climate zones (up to 40°C and humidity of 70%), the inlet temperature (coolant) can fall up to 5 K below the ambient temperature.
- The cooling unit must be switched off during longer standstill periods

Please take note of any deviating details specified on the nameplate or in the technical documentation. The conditions at the place of utilization must correspond to the details on the rating plate.

| | |
|---|--|
|  | <p>Utilization in hazardous areas is prohibited, unless the unit is expressly designed for this purpose (refer to additional notes). Furthermore, the area surrounding the electric motor must be free of inflammable gas mixtures and concentrations of dust. Live and hot motor parts are inflammable and may cause serious injury and damage to property.</p> <p>If, in special cases, greater requirements are placed – for utilization in non-industrial applications – (e.g. protection against contact with a child's fingers), these conditions must be by the customer met when installing the system.</p> |
|---|--|

Motor design with rare-earth magnets:

| | |
|---|--|
|  | <p>The rotors of the DST motors have rare-earth magnets with high magnetic energy densities. High forces of attraction to ferromagnetic components occur near a dismantled rotor, persons with pacemakers are in great danger, data stored on electronic data media could be destroyed. Incorrect handling can result in injury when ferromagnetic parts are attracted by the rotor.</p> |
|---|--|

Thermal hazards:

| | |
|---|--|
|  | <p>Caution! Highly inflammable!</p> <p>Temperatures of over 70°C can build up on the motor surfaces. Touch contact measures should be implemented if necessary!</p> <p>Temperature-sensitive parts, e.g. normal cables or electronic components, must not be placed on or fixed to the hot surfaces.</p> <p>Thermal overloading can destroy the winding and the bearing. A thermal sensor should be used to monitor the temperature.</p> |
|---|--|

1.3 Prohibition of unauthorised modifications and changes



For safety reasons, unauthorised modifications and changes to the electric motor are not permitted. If such modifications / changes are necessary, please contact the manufacturer.

No safety devices may be dismantled or decommissioned prior to the operation of the device.

2 Operating conditions

2.1 Product description

Electric motors of the series “**DS...W**” are permanently excited three-phase synchronous motors with rare-earth magnets. They are liquid-cooled (water-based coolant) and, due to the efficient cooling, have a high torque and power density at a high enclosure. The elimination of the fan unit significantly reduces motor noise emission.

When operating with a motor-controlled pulse converter, the speed and position of these compact motors can be optimally controlled. These drives have a high overload capacity and are therefore ideally suited for applications in mechanical engineering.

2.2 Scope of supplies

The delivery is put together on an order-related basis.

- The carrier must immediately be notified of any damage caused during transport.
- On delivery, please check that the ratings and motor type correspond with the order data. In the event of apparent defects or incomplete delivery, the appropriate Baumüller office or the Baumüller head office in Nuremberg should be notified immediately.

In both of the above cases, commissioning must not take place until the error has been rectified by a specialist.

2.3 Nameplate

The nameplate is used to identify each electric motor. The respective motor number is clearly shown on the nameplate and is essential for internal tracking procedures. It must be possible to read the nameplate at all times. Never remove the nameplate from your motor.

Nameplate data:

| | | |
|----------------------|----------|--------------------------|
| Mot. no.: | | Motor number |
| Type; | DS... | Motor type / Description |
| U: |V | Rated voltage |
| I: |A | Rated current |
| n: |rpm | Rated speed |
| P: |KW | Rated power |
| Cos φ | | Power factor |
| f : | Hz | Rated frequency |
| Insul. class: | F | Insulation material clas |
| Mode: | | Motor operation mode |
| IP: | | Motor protection type |

2.4 Technical data

| | |
|--|--|
| Designs (EN 60034-7) | IM B3, IM B5 (frame size 100 - 160) IM B3, IM B35 (frame size 200) |
| Type of protection (EN 60034-5) | IP 54 |
| Cooling method (EN 60034-6) | IC 3W7 (liquid-cooled) |
| Electrical connections (comp. Appendix 1) | |
| Main connection | Terminal box |
| Control connection | Resolver - 12-pole connector |
| Brake (optional) | Connection on brake |
| Thermal sensor | Connection in terminal box |
| Thermal motor protection (EN60034-11) | Thermal sensor KTY84 in stator winding |
| Winding insulation (EN 60034-1) | Insulation class F |
| Ambient temperature (EN 60034-1) | 0°C... +40°C (see Appendix 2 for max. inlet temperature of cooling water) |
| Installation (EN 60034-1) | ≤ 1,000 m a.m.s.l. |
| Storage | -30°C...+60°C (+ 85°C, comp. Chap. 2.5) |
| Note: To avoid frost damage, cooling water should be removed at temperatures of < 3°C! | |
| Bearing | Rolling-contact bearing with grease lubrication for life |
| Calculated bearing life | 20.000h (tentative value) |
| Vibration severity (EN 60034-14) | Level N |
| Vibration-proof (EN 60068-2-6) | Radial 3g (20Hz to 55 Hz) Axial 0.5g (20Hz to 55 Hz) |
| Holding brake | Option |
| Actual speed encoder | Standard: 2-pole Resolver |

For further technical values, please refer to the technical documentation that comes with the product DS...W.

Attention!

If the electric motor supplied is not a standard version in accordance with the technical documentation or if special arrangements were contractually agreed, the technical data may differ to the values stated in these Commissioning and Maintenance Instructions. The supplementary technical details are available on request.

2.5 Transport, intermediate storage

Transport:

| | |
|---|---|
|  | <p>Suitable load suspension material must be used, e.g. belt webbing, loop belts etc. If provided, the lifting lugs of the motor can be used for lifting.</p> <p>The terminal boxes or motor connectors must not be used as shipping braces or lifting lugs.</p> <p>The regulations in the respective countries must be adhered to during transport. Lifting devices, transport and load suspending devices must comply with the regulations.</p> |
|---|---|

The Baumüller electric motors of the “**DS...W**” series weigh up to approx. **600 kg**. Precise details relating to the weight of the respective devices can be found in the technical documentation.

The motor shaft and the connection surfaces must be protected against corrosion. The motor must be transported with motor shaft covering to prevent unnecessary damage to the shaft.

Intermediate storage:

If a motor is not to be commissioned immediately after delivery, it should be stored inside a building in a dry, dust-free and low-vibration room ($V_{\text{eff}} = 0.2\text{mm/s}$).

The electric motors can be stored for a maximum of two years at -30°C to $+60^{\circ}\text{C}$. High storage temperatures up to a max. of $+85^{\circ}\text{C}$ are permitted, but this can, however, lead to the ageing of the gaskets. Direct exposure to incident solar radiation, UV light and ozone can also lead to an ageing of the gaskets and must be avoided!

To avoid frost damage, cooling water should be removed at temperatures of $< 3^{\circ}\text{C}$!

Please note that the warranty periods commence from the date of delivery. For this reason, we recommend that storage periods be reduced to a minimum.

2.6 Installation conditions, cooling details

Surroundings:

The motor can be installed in roofed over rooms with dusty or damp ambient conditions and normal climatic conditions. The motor must not be brought into contact with aggressive, corrosive, abrasive or plastic-dissolving solutions.

Consultation with the motor manufacturer is essential in the case of outside installation.

Ambient conditions comp. **Chap. 2.4** and the technical documentation that comes with the product.

Cooling details:

| | | | | |
|----------------------------|----------|----------|----------|----------|
| Frame size | 100 | 132 | 160 | 200 |
| Connections forward motion | 1 | 1 | 1 | 2 |
| reverse motion | 1 | 1 | 1 | 2 |
| Connecting thread | G1/2" IG | G1/2" IG | G1/2" IG | G1/4" IG |
| Direction of flow | as req. | as req. | as req. | as req. |

Coolant: in accordance with Baumüller water specification (comp. **Appendix 2**)
Additives in closed cooling circuit for corrosion protection are permitted.

| | |
|---|---|
|  | <p>The safety instructions provided by the producer of the anticorrosive agent, e.g. DIN Safety Sheet, must be observed</p> <p>Cooling lubricants employed in manufacturing processes may not be used to cool the motor!</p> <p>To prevent blockages in the coolant pipes and channels, coolants used in closed or open cooling circuits must be filtered. When used in a closed cooling circuit, the coolant must be filtered before it is poured in, in open cooling circuit basically (filter fineness: 0.1 mm).</p> |
|---|---|

Please note: The system manufacturer is responsible for the planning of the cooling circuit.
Condensation water must not be allowed to accumulate (comp. **Chap. 1.2**)

2.7 Balancing, drive elements and vibration

| | |
|--|--|
|  | <p>The shaft and bearing must not be exposed to knocks.</p> <p>No axial forces are permitted when mounting or dismounting the output elements. The generally required measures to prevent contact with the output elements must be observed.</p> <p>If the motor is commissioned without the output element, the featherkey must be secured to ensure that it is not thrown out.</p> |
|--|--|

Balancing

In the standard version, the rotors are balanced dynamically with half the featherkey inserted.
(In accordance with DIN EN 60034-14 / ISO 1940)

NOTE: The balancing method is marked on the shaft end face:
H = Balancing with half featherkey - standard version
F = Balancing with full featherkey - special version

Output elements:

When assembling the output element, make sure that the correct balancing method is used. The output elements must be balanced in accordance with ISO 1940.

Suitable devices should always be used to push on or pull off the output elements (e.g. coupler disk, gear wheel or belt pulley).

- Use tapped hole at end of shaft.
- When pulling off, use spacer washer for mechanical protection of shaft.
- If necessary, heat the output element.

Caution:

- If the shaft does not have a featherkey, the output elements are fixed to the drive shaft using **appropriate clamping bushes**.
- In the case of shafts with a featherkey, **make sure that the output elements lie against the shoulder of the shaft**. Note: The chamfer or radius at the output element and the shaft radius at the shoulder (in accordance with DIN748-E) must be harmonised.

Vibration:

| | |
|---|---|
|  | <p>The site vibration response of the system, which is determined by the output elements, the mounting conditions, the alignment, the installation and the effects of external vibrations, may cause the vibration values at the motor to increase.</p> <p>In the interest of reliable motor operation and a long bearing service life, the permitted vibration values in accordance with EN 60034-14 should not be exceeded. Under certain circumstances, the rotor may need to be fully balanced with the output element (in accordance with ISO 140).</p> <p>The vibration value after assembly must not exceed the permitted rates of acceleration (comp. Chap. 2.4)</p> <p>In the event of deviations from normal operation – e.g. rise in temperature, noises, vibration – disable the motor. Identify the cause and, if necessary, contact the manufacturer.</p> |
|---|---|

3 Mounting

3.1 Safety instructions

Before mounting:

| | |
|---|---|
|  | <p>Never mount or commission a damaged electric motor.</p> <p>Never install the electric motor in a damaged machine.</p> <p>Before mounting the electric motor, make sure that it is suitable for your machine.</p> |
|---|---|

During mounting:

| | |
|---|---|
|  | <p>Only mount the motor on the fixing possibilities provided.</p> <p>The motor should not be exposed to knocks, e.g. with a hammer, or shocks when mounting.</p> <p>Make sure that all covers and safety devices are mounted. All safety devices must comply with the latest regulations (e.g. EN 60204).</p> <p>Water cooling:</p> <p>To avoid damaging the housing, only screwed sockets with a cylindrical thread may be used for the water connections (inlet and outlet).</p> <p>The coolant pipes should not exert compression-tension forces or torsional strain on the motor connections.</p> <p>The hydraulic connection must be carried out by specially trained personnel. Here, the motor must be disconnected and de-energized.</p> <p>When coupling and uncoupling the coolant pipes, make sure that coolant does not enter into the motor's terminal box.</p> |
|---|---|

3.2 Installation, fixing

Prior to and during mounting, check that

- the motor is not damaged (e.g. the shaft sealing ring should not be damaged in any way by sharp objects).
- the motor is not mounted in the danger zone of other facilities.
- the motor is used for the designated purpose. (See chapters 1.2 and 2.4) (observe nameplate details, warning labels and signs.)
- anti-corrosive agents are fully removed from the shaft ends.
When using standard solvents such as Acetone or benzine, the shaft sealing ring must not be moistened!
- the motor is designed for the ambient conditions and environmental influences on site. (See chapter 2.4)
- the compartment in the machine is suitable for the cooling method employed by the electric motor. (See chapter 2.6)
The motor must be installed in such a way that the coolant lines can subsequently be connected.
- the motor can be mounted and operated with the connection data and fixing possibilities provided.
The mounting dimensions of the motor and the tolerance details are provided in the technical documentation.
When mounting the flanges on the motor, make sure that the flange surface rests well and evenly. The supports and bearing surface must be clean and undamaged. They must be precisely aligned with the connecting shafts to prevent the bearing, shafts and housing being exposed to damaging loads through misalignment. When tightening the flange fixing screws, (min. property class 8.8) make sure that the flange connection is not twisted.
- no liquid can penetrate the upper bearing when installing vertically with the shaft end facing upwards.
- the permitted radial forces in accordance with the operating characteristics in the technical documentation are not exceeded. If necessary, contact Baumüller.
The motor manufacturer must always be contacted in the case of axial forces.
- the brake (optional) can be released after feeding the operating voltage (audible creaking sound).
- the rotor rotates smoothly without making a scraping sound.
If the motor is equipped with a brake, the brake should be released previously.
- the design of the motor and encoder cables complies with the details in the technical documentation.
- the output and input elements are secured.
- the complete cooling circuit is leak proof and fully functional



Leak test:

The tightness of the coolant circuit must be checked before commissioning by means of a pressure test with the coolant (water) in accordance with VDE 0160 (05/88) at twice the working pressure but not, however, under 1 bar. The coolant should not be brought to operating temperature. The pressure must be maintained until the tightness of the entire circuit has been checked. The test should be carried out for at least 10 minutes.



3.3 Electrical connections

Important notes:

| | |
|---|--|
|  | <p>All work must be carried out by specially trained personnel.</p> <p>Work must only be carried out when the system has been de-energized and secured against unintentional restarting (also auxiliary circuits).</p> <p>Work may only be carried out once the machine has come to a standstill. In the case of three-phase synchronous motors with permanent-magnet excitation, a voltage of > 60 V can occur at the motor terminals when the rotor is turning.</p> <p>Regulations for working in electrical plants must be adhered to!</p> |
|---|--|

The safety regulations for work in electrotechnical plants in accordance with EN 50110-1 (DIN VDE 0105-100) must be observed:

- Disconnect the system
- Secure against unintentional restarting
- Verify safe isolation from supply
- Earth and short
- • Safeguard or cover adjacent live parts

| | |
|---|---|
|  | <p>The electric motor must be operated via a correspondingly designed converter. A direct connection to the three-phase mains can destroy the motor.</p> <p>Ensure that the phase sequence and the pin assignment are correct!</p> <p>Electrical connections, protective conductor connections and screening connections (when using screened cables) must be permanently secure!</p> |
|  | <p>Never touch the contacts of the encoder or thermal sensor with your hands or with tools that are electrostatically charged. The encoder and the thermal sensor are electrostatically sensitive components.</p> |

Electrical installation:

- The supplier of the system is responsible for the correct electrical installation.
- The motor data on the nameplate must be observed.
- Connection cables and plug connections must be checked for any occurring voltages and current intensity and must be suitable for the method of installation employed.
- The motor and the modules (brake, encoder) must be connected in accordance with the details in the wiring diagrams (comp. enclosed wiring diagrams / **Appendix 1**).
- Screened power and encoder cables must be used to protect against electromagnetic EMC interference from motor cables and their effect on the encoder and control system. Please refer to the EMC notes provided by the supplier of the converter.
- To enhance operational safety, we recommend that the ready-made connection cables from Baumüller be used.
- Prior to connection, the female connectors, connectors and terminal box must be checked for damage, corrosion, dirt and dampness.
- Make sure that the screwed connections are correct and tight. Check gaskets and faces of connectors and terminal boxes to guarantee protection type.
- Connectors and terminal box connections must not be exposed to mechanical stress. If necessary, provide strain, shearing, twist and antikink relief.

When the power cable is connected via the terminal box, make sure that

- the insulation is not over stripped, i.e. that the insulation extends right up to the cable lugs or terminals. The ends of the cables must not protrude.
- the cable lugs that are used are suitable for the dimensions and cross-sections of the terminals and cables.
- the screwed electrical connections are tightened in accordance with the specified tightening torque. (comp. **Appendix 1** and technical documentation on the product)
- the protection type is maintained.

Note: All lead-ins that are not used must be closed off with the sealing caps. The sealing elements must be fully functional and undamaged when closing the terminal box.



4 Commissioning, operation

4.1 Safety instructions

Working on the electric motor:

| | |
|---|--|
|  | <p>Work must not be carried out on the electric motor until the motor had come to a standstill and is de-energized. All connections, such as screw connections, that were loosened must be tightened again prior to commissioning.</p> <p>When carrying out work on the motor, please observe the technical instructions and notes in the respective chapters in these Commissioning and Manitenance Instructions.</p> |
|---|--|



Danger to life through electrical shock:

| | |
|--|---|
|   | <p>Make sure that the motor is disconnected and de-energized.</p> <p>Never disconnect the motor connections while in operation.</p> <p>Only connect measuring device when motor is disconnected from power supply and de-energized.</p> <p>Only commence work on the motor connections when you are sure that the motor is de-energized and that there is no electric potential.</p> <p>When in operation, electric potential can be found at the motor terminals/contacts and at the motor windings. Never touch these modules/elements while the motor is in operation.</p> |
|--|---|

Dismantling the safety devices:

| | |
|---|--|
|  | <p>The electric motor must not be commissioned without first mounting the safety devices.</p> <p>When dismantling safety equipment during commissioning, ensure that the machine is taken out of commission.</p> <p>Remount the safety devices immediately after completing commissioning.</p> |
|---|--|

Danger on contact:

| | |
|---|---|
|  | Make sure that the electric motor has come to a standstill and is secured against accidental restarting before you touch it. |
|  | Danger of burns! Never touch the motor housing when motor is running at rated load. Surface temperatures can rise up to 70°C. |

4.2 Checks prior to commissioning

- The drive is undamaged and is not located within the danger zone of other equipment
- The motor is correctly aligned and fixed. All screwed connections are correctly tightened.
- All the appropriate safety devices (mechanical, thermal and electrical) are mounted.
- The motor connections have been carried out correctly.
- The protective conductor system is correct and its functionality has been checked.
- The lines and cables do not come into contact with the motor surface.
- The drive does not block (release brake, if applicable).
- Emergency OFF functions have been checked.
- The coolant pipes have been properly corrected and the functionality of the cooling circuit has been tested.

4.3 Commissioning, operation

Note on the brake functions (is brake is fitted):

| | |
|---|---|
|  | The brake is a holding brake with an emergency STOP function. (power cut, emergency stop) (see technical documentation for permissible data) |
| | The brake must not be used as a working brake. |

Commissioning must be carried out exclusively by qualified personnel

Please refer to the commissioning instructions for the converter and the cooling system.

Checks during commissioning



- Release brake, if applicable.
- Has the functionality of all motor modules such as the brake, encoder, cooling system been checked and are the utilization conditions being adhered to?
- Have all electrical connections been carried out and fixed as required by the regulations. (Refer to wiring diagrams / Appendix 1)
- Have all protection measures that eliminate the possibility of contact with live parts, hot surfaces, rotating and moving parts been observed and are these measures fully functional.
- Have all output elements been mounted and set in accordance with the manufacturer's instructions.
- Are measures in place to ensure that the max. permitted speed n_{max} of the motor cannot be exceeded. The max. permitted speed n_{max} is the highest permitted operating speed for short-time duty.

Checks during operation

- Watch out for unusual noises.
- If scraping, scratching or grinding noises occur, stop the motor immediately and locate the cause.
- Check the motor surface and connection cables for dirt, e.g. layers of dust, oil deposits, dampness and leaks etc.
- Check the maintenance intervals.

4.4 Malfunctions

Safety instructions:

| | |
|---|---|
|  | Troubleshooting and error recovery may only be carried out by qualified personnel. Do not disconnect any of the safety devices – even during test operations Only disconnect coolant pipes when depressurized |
|  | Only disconnect and connect electrical connection cables when in de-energized and protected condition Observe the 5 safety rules for “Disconnecting” (comp. Section 3.3). |
|  | Beware of hot surfaces! |

In the event of a malfunction

- refer to the operating instructions of the machine/system
- refer to the operating instructions for the converter
- If necessary, contact the manufacturer of the motor or converter

Have the following parameters ready:

nameplate data
type and scope of malfunction
circumstances leading up to the malfunction
application data (torque cycle, speed and forces over time; ambient conditions)

The following selection possible causes can be helpful in the fault correction process:

| Fault | Cause | Recovery |
|----------------------|--|--|
| Motor does not start | No controller enable Controller error, encoder error Brake does not release Brake defect No power supply Rotating field | Activate controller enable Read out error list at converter or controller, rectify error Check connections and power supply Repair by manufacturer Check connections and power supply Check phase sequence, if necessary, replace connecting cables |
| Uneven running | Insufficient screening on connecting cables Controller parameters too high | Check screening connection and grounding Optimise controller parameters |

| Fault | Cause | Recovery |
|--|---|---|
| Vibrations | <p>Coupling element or work machine poorly balanced</p> <p>Inadequate alignment of the drive train</p> <p>Fixing screws loose</p> | <p>Rebalance</p> <p>Realign machine set</p> <p>Check and tighten screwed connections</p> |
| Running noises | <p>Foreign matter in motor</p> <p>Damaged bearing</p> | <p>Repair by motor manufacturer</p> <p>Repair by motor manufacturer</p> |
| <p>Temperature rise in motor</p> <p>Motor temperature monitoring unit responds</p> | <p>Drive overloaded</p> <p>Brake does not release fully - scraping brake</p> <p>Water cooling not active.</p> <p>Coolant supply inadequate</p> <ul style="list-style-type: none"> - filter urgently requires cleaning - deposits in cooling channels - disturbances in external cooling system | <p>Check motor load and compare with nameplate</p> <p>Repair by motor manufacturer</p> <p>Check and, if necessary, switch on</p> <p>Check water circuit</p> <ul style="list-style-type: none"> - check and, if necessary, clean - check and, if necessary, clean - follow system supplier's instructions |
| Excess pressure in cooling system | <p>Coolant impure</p> <p>Cooling channels blocked</p> <p>Disturbances in the external cooling system</p> | <p>Filter coolant</p> <p>Check and, if necessary, clean</p> <p>Follow system supplier's instructions</p> |
| Current consumption too high, motor torque too low | Indexing angle incorrect | Check indexing angle and adjust if necessary |

5 Inspection and maintenance

Working on the electric motor:

| | |
|---|---|
|  | <p>Work must not be carried out on the electric motor until the motor has come to a standstill, is de-energized, depressurised and has cooled. All connections, such as screw connections, that were loosened must be tightened again after the inspection or maintenance work.</p> <p>When carrying out work on the motor, please observe the technical instructions and notes in the respective chapters in these Commissioning and Maintenance Instructions.</p> <p>When carrying out maintenance work, observe all safety instructions which also apply for the commissioning of the motor (comp. Section 4.1)</p> <p>Attention: the optional holding brake does not have a securing function when work is being carried out on the motor (e.g. holding loads)!</p> |
|---|---|

5.1 Inspection

Depending on the pollution severity on site, cleaning will have to be carried out regularly to guarantee the continuous dissipation of heat loss. The flow rate and the pressure ratio of the cooling system must be checked.

If equipped with the optional brake, certain abrasion limits are specified (e.g. max. permitted ventilation slot, limited emergency braking). The degree of abrasion must be checked on a regular basis. The brake must be replaced on reaching the permitted abrasion limit (comp. Section 5.2)

If equipped with the optional shaft sealing ring, this must be checked regularly to ensure that it is functioning correctly (leaks).

5.2 Maintenance

Depending on the operating conditions, (e.g. mode, temperature, speed and load), the service life of the bearings and sealing elements can differ greatly.

In the case of troublefree operation, we generally recommend the following maintenance procedures:

- replacement of the bearings after 20,000 running hours (The bearings are designed for a calculated service life of 20,000 running hours)
- replacement of the shaft sealing ring, if provided, and if no leaking is detected in the course of previous inspections, after approx. 5,000 running hours.

If equipped with the optional brake, this must be replaced when the specified abrasion limits have been reached.

Maintenance work must be carried out by Baumüller or a specialist company that is commissioned by Baumüller.

6 Disposal

The motor must be disposed off in accordance with the national and local regulations within the framework of the normal recycling process.

The encoder electronics (if provided) must be disposed of in the proper manner as electronic scrap.

7 Appendix 1

Terminal marking / Main connection:

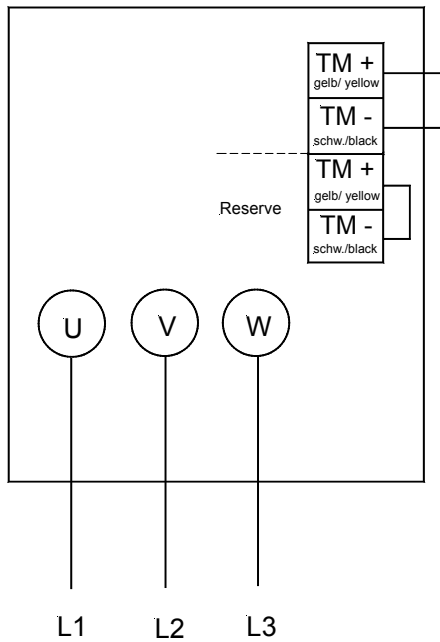

U V W -----Power connection

TM + TM - -----Thermal sensor

Caution:

If using the thermal sensor KTY 84, attention will have to be paid to the polarity during connection.

Connection assignment / Main connection

The cable inlets of the terminal boxes and the main connection terminals are listed below together with the permitted tightening torque.

We recommend EMC screwed fittings for the cable inlets.

It is recommended when tightening the terminal screw to support against the conductor to prevent mounting rail deformation and to keep the terminal base free of torsional forces.

| Motor frame size | Cable gland | Number of main connection terminal | Tightening torque for terminals [Nm] |
|------------------|----------------------|------------------------------------|--------------------------------------|
| 100 | 1 x M 40 + 1 x M 25 | 3x pluggable | - |
| 132 | 2 x M 63 + 1 x M 25 | 3x M 10 | 10 |
| 160 | 2 x M 63 + 1 x M 25 | 3 x M 10 | 10 |
| 200 | 2 x M 63 + 1 x M 25 | 3 x M 12 | 15,5 |
| | 2 x M 75* + 1 x M 25 | 3 x M 16 | 30 |

* terminal box screening led into terminal in terminal box.

Composition: terminal box designs

Other cable glands and connection terminals are only available on request.

Terminal marking / Resolver connection:

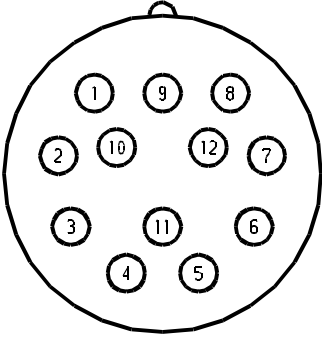
| | | |
|---|----|-------|
|  | 1 | cos - |
| | 2 | |
| | 3 | |
| | 4 | |
| | 5 | sin - |
| | 6 | sin + |
| | 7 | |
| | 8 | cos + |
| | 9 | |
| | 10 | Ref + |
| | 11 | |
| | 12 | Ref - |

View to contact side of female connector

Pin assignment / Resolver

Other encoder types:

Pin assignment corresponds to enclosed wiring diagram or technical documentation.

8 Appendix 2

In accordance with Baumüller water specifications / as on 2004/12

Requirements for an open (and closed) cooling circuit

| Conditions | Unit | Value |
|---|------|------------------------|
| Max. permitted system pressure | Bar | 6 |
| Temperature of coolant ¹⁾ - for motor | ° C | 10 ¹⁾ to 35 |
| Max. temperature rise | K | 13 |
| pH-value (at 20° C) | --- | 6.5 to 9 |
| Overall hardness | °dH | 8 to 14 |
| Chloride - Cl- | mg/l | < 200 |
| Sulphate - SO ₄ ²⁻ | mg/l | < 200 |
| Oil | mg/l | < 1 |
| Permitted grain size solid foreign bodies or particles (e.g. sand) | mm | < 0.1 |

- 1) Condensation water must not be allowed to accumulate:
 Inlet temperature (coolant) = ambient temperature (e.g. temperature control).
 In moderate climate zones (up to 40°C and humidity of 70%), the inlet temperature (coolant) can fall up to 5 K below the ambient temperature.

The cooling unit must be switched off during longer standstill periods

The coolant used should be clear, clean water that is free of suspended matter.

Details relating to the amounts of coolant required

The following cooling amounts are required to cool the motors:

| DS frame size | 100 | 132 | 160 | 200 |
|-----------------------------------|------------|------------|-----------|------------|
| Flow rate [l/min] (min.) | 7 (4,5) | 9 (6.5) | 10 (7) | 13 (11) |
| Pressure drop [bar] | 0.29±10% | 0.33±10% | 1.05±10% | 1.7±10% |
| Temperature rise [K] (max.) | 6 (10) | 7 (10) | 8 (11) | 11 (13) |
| Max. coolant pressure [bar] | 6 | 6 | 6 | 6 |

- 1) provisional details

Warranty and liability

All the details in this documentation are unbinding customer information and subject to ongoing change and will be continuously updated by our permanent editing staff. Warranty and liability claims against Baumüller Nürnberg GmbH are excluded if, in particular, the damage is caused by one or more of the following:

- You have not followed the instructions in this documentation.
- You have not used the system for the purpose intended.
- You have
 - mounted, installed, commissioned, operated the system incorrectly or have not carried out the required maintenance
 - permitted the system to be mounted, installed, operated and/or maintained by unqualified or insufficiently qualified personnel,
 - overloaded the system,
 - operated the unit with
 - faulty safety devices,
 - safety devices that were incorrectly fitted or not fitted
 - safety devices or protective devices not in proper working order,
 - not operated the system in the stipulated ambient conditions.
- You have modified the system without the written approval of Baumüller Nürnberg GmbH.
- You have not observed the instructions concerning maintenance in the component descriptions.
- You have not monitored parts subject to wear sufficiently.
- You have made a repair incorrectly.
- You have combined the system with the products from other manufacturers in an improper manner.
- You have combined the drive system with faulty and/or incorrectly documented products from another manufacturer.

The "General Terms and Conditions of Sale" Version 1.1 of 15 February 2002 or the latest version drawn up by Baumüller Nürnberg GmbH always apply.

These are available to you, at latest, on the conclusion of the contract.

Drive Center National

Darmstadt

Baumüller Griesheim GmbH & Co. KG
Waldstraße 1 • D-64347 Griesheim
Tel +49- (0)6155-8430-00 • Fax +49- (0)6155-8430-20

Düsseldorf

Baumüller Nürnberg GmbH
Jacob-Kaiser-Str. 7 • D-47877 Willich-Münchheide
Tel +49- (0)2154-487-0 • Fax +49- (0)2154-487-59

Dresden

Baumüller Kamenz GmbH
Nordstraße 57 • D-01917 Kamenz
Tel +49- (0)3578-3406-0 • Fax +49- (0)3578-3406-50

Hannover

Baumüller Nürnberg GmbH
Bohlenweg 10 • D-30853 Langenhagen
Tel +49-(0)511-771968-0 • Fax +49-(0)511-771968-77

Nürnberg / Bayern

Baumüller Nürnberg GmbH
Ostendstr. 80-90 • D-90482 Nürnberg
Tel +49- (0)911-5432-501 • Fax +49- (0)911-5432-510

Stuttgart

Baumüller Griesheim GmbH & Co. KG
Hahnweidstr. 21 • D-73230 Kirchheim / Teck
Tel +49- (0)7021-48557-10 • Fax +49-(0)7021-48557-77

Drive Center International

Australia / Sydney

Baumüller Australia Pty. Ltd.
Unit 4, 476 Gardeners Road
Alexandria NSW 2015, Australia
Tel +61 2 8338-0386 • Fax +61 2 8338-0389

Australia / Melbourne

Baumüller Australia Pty. Ltd.
45 Jarrah Drive • Braeside Vic. 3195, Australia
Tel +61 3 9580-9522 • Fax +61 3 9587-3886

China / Hong Kong

Baumüller Australia Pty. Ltd.
13H, Block 4, Carado Garden,
Tai Wai • N.T., Hong Kong
Tel/ Fax +852 2695-9755 Handy +852 9194-1582

England

Baumüller (UK) Ltd.
14 Redlands Centre • GB-Coulsdon, Surrey CR5 2HT
Tel +44 (0)208-763 2990 • Fax +44(0)208-76329-59

France

Baumüller France S.à.r.l.
Zone de la Malnoue
39, Avenue de l'Europe • F- 77184 Emerainville
Tel +33 1 6461-6622 • Fax +33 1 6461-6006

India

Baumüller KAT India Pvt. Ltd.
Dattaprasad Apartment • Flat No. 7, 3Rd Floor,
B/7, 1206, APTE Road • IND- 411 004 Pune
Tel +91 20 5513311 • Fax +91 20 5513388

Italy

Baumüller Italia s.r.l.,
Viale Italia, 12 • I-20094 Corsico (Mi),
Tel +39 02 45100-181 • Fax +39 02 45100-426

Netherlands

Baumüller Benelux B.V.
Platinastraat 141 • NL-2718 SR Zoetermeer
Tel +31(0)79-3614-290 • Fax +31(0)79-3614-339

Austria

Baumüller Austria Ges.mbh
Im Bäckerfeld 17 • A-4060 Leonding
Tel +43 (0)732 674414-0 • Fax +43 (0)732 674414-32

Switzerland

Baumüller Suisse S.A.
Rue des Usines 22 • CH-2000 Neuchâtel
Tel +41 (0)32 7301-260 • Fax +41 (0)32 7301-351

Slovenia

Baumüller Dravinja d.o.o.
Delavska cesta 10 • SI-3210 Slovenske- Konjice
Tel +386 3-75723-00 • Fax +386 3-75723-32/33

Spain

Baumüller Ibérica S.A.
Ausias Marc, 13 1º 2ª • E- 08010 Barcelona
Tel +34 (0)93 34 26 926 • Fax +34 (0)93 27 01 321

Turkey

**BAUMÜLLER MOTOR KONTROL SISTEM
SAN. VE TIC. LTD. STI**
Colak Ismail Sok., No: 31/1 • TR-81070 Istanbul-Suadiye
Tel +90 (0)216 372-2485 • Fax +90 (0)216 372-7570

USA

Baumüller Hartford Inc.
117 West Dudley Town Road • USA-Bloomfield,
CT 06002
Tel +1 860-243 0232 • Fax +1 860-286 3080

USA

Baumüller Chicago Corp.
405 Algonquin Rd. • USA-Mount Prospect, Ill 60056
Tel +1 847 956-7392 • Fax +1 847 956-7925

Dealers International

Brazil

NC SERVICE INDÚSTRIA E COMÉRCIO LTDA.
Av. Juruá, 150, - Barueri - SP • BR- 06455 - 010
Tel +55 (0)11 4195-0502 • Fax +55 (0)11 4195-2479

Iran

PAK GOSTAR Co.
502, 5th Floor, BORJ-E SEFID, PASDARAN Ave
TEHRAN - IRAN
Tel +98 21 2553868-70 • Fax + +98 21 2547703

Japan

NUSCO CO Ltd.
6-17-8 Nagayama, Tama, Tokyo • J- 206-0025
Tel +81 (0)423 73-1621 • Fax +81 (0)423 73-1821

Korea

BOMAC SYSTEMS
712 Yucheon Factophia • 196 Anyang-7 dong, Mananku,
Anyangsi, • Kyungkido 430-017, Korea
Tel +82 31 467-2030, • Fax +82 31 467-2033

Russia, Kazakhstan

Elektroprivod J.-s.
st. Sadovaja- Spaskaja
h. 1/2, b.2 • Moscow ,107078
Tel +7 (0)95 2082-160 • Fax +7 (0)95 2082-623

Poland

MECTEC POLSKA
Ul. Mickiewicza 19 • PL-60833 Poznań
Tel. / Fax +48 (0)61-8470553

Sweden

OCTAB Industrietechnik AB
Maskingatan 8B • SE-195 60 Märsta
Tel +46 (8) 591 150-00 • Fax +46 (8) 591 150-01

Spain

Ofisistelec, S.L.
Poligono Industrial Virgen de los Dolores
E-46113 Moncada (Valencia)
Tel +34 96 144-5055 • Fax +34 96 144-5311

Czech Rep.

ATEM CNC- TECHNIK spol.s.r.o.
V domove 4 • CZ- 130 00 Praha 3
Tel u. Fax +420 222587698

Hungary

MELTRON KFT.
Gyömroi ut. 128. • H-1103 Budapest
Tel/ Fax +36 1 264 - 9482

USA

Industrial Drives Design, Inc.
668 Flinn Avenue Unit 28 • USA- Moorpark
CA 93021
Tel +1 805 378-1170 • Fax +1 805 378-1171

Venezuela, Columbia, Ecuador

Nimbus International C.A.
C.C. Parque Tuy, Local P-18
YV-Ocumare del Tuy 1209
Tel +58(0)39-251347 • Fax +58(0)39-257149

Production

Motors

Baumüller Nürnberg GmbH
Ostendstraße 80- 90 • D-90482 Nürnberg
Tel +49- (0)911-5432-0 • Fax +49- (0)911-5432-130

Baumüller Nürnberg GmbH

Werk Kitzingen
Floßhafenstraße 2 • D-97318 Kitzingen
Tel +49- (0)9321-70080 • Fax +49- (0)9321-700888

Baumüller Brno s.r.o

Skalice nad Svitavou 72
CZ- 67901 Skalice nad Svitavou,
Tel +420 516-499 111 • Fax +420 516-499 117

Baumüller Kamenz GmbH

Nordstraße 57 • D-01917 Kamenz
Tel +49- (0)3578 3406-0 • Fax +49- (0)3578 3406-50

Small motors

Baumüller Nürnberg GmbH

Werk Bad Gandersheim
Flugplatzweg 2 • D-37581 Bad Gandersheim
Tel +49- (0)5382 9805-0 • Fax 49- (0)5382 9805-55

Electronics

Baumüller Nürnberg Electronic GmbH & Co.
Ostendstraße 80- 90 • D-90482 Nürnberg
Tel +49- (0)911-5432-293 • Fax +49- (0)911-5432-328

Sheet metal forming

Baumüller Dravinja d.o.o.

Delavska cesta 10 • SI-3210 Slovenske- Konjice
Tel +386 3-75723-00 • Fax +386 3-75723-32/33

System engineering

Baumüller Anlagen-Systemtechnik GmbH & Co. KG

Ostendstraße 84 • D-90482 Nürnberg
Tel +49- (0)911-54408-0 • Fax +49- (0)911-54408-749

Services

Baumüller Reparaturwerk GmbH & Co KG

Andernacher Straße 19 • D-90411 Nürnberg
Tel +49- (0)911-9552-0 • Fax+49- (0)911-9552-999

Munich

Baumüller München GmbH

Meglingerstraße 58 • D-81477 München
Tel +49- (0)89-748898-10 • Fax +49- (0)89-748898-75