



**Commissioning  
and Maintenance Instructions**

**be in motion be in motion**



**TAM 00682**

**DSC 045 - 100**

Three-phase synchronous motor

**Version: 07/ 2012**

**English**



## LEGAL NOTES ON DOCUMENTATION

### *Copyright*

This documentation may only be copied, as many times as required, by the owner for internal use. For other purposes, this documentation may not be copied or duplicated either in whole or in part. Utilization by and provision of the contents to third parties is not permitted. Names and company logos used in this documentation may be trademarks, whose use by third parties for their own purposes may infringe the rights of the owner.

### *Applicability*

This documentation is part of the unit/the machine. These Commissioning and Maintenance Instructions must be available to the operator at all times and be in a readable condition.

If the unit/machine is sold or put into storage, the owner must pass on this documentation together with the unit/machine. Following the sale of the unit/machine, this original and all copies are to be passed on to the purchaser. Following disposal or any other form of termination of utilization, this original and all copies are to be destroyed.

With the introduction of this documentation, corresponding documentation with earlier issue dates is superseded.

Please note that all data/figures/information represent **current data at the time of going to press**. These details are **not legally binding** for the purposes of dimensioning, computation, or calculation.

Baumüller Nürnberg GmbH reserves the right to change the technical data and the method of operation of Baumüller products in the context of the further development of the products.

No liability can be accepted concerning the correctness of this documentation unless otherwise specified in the General Conditions of Sale and Delivery.

BAUMÜLLER NÜRNBERG GmbH

Motors division

90482 Nürnberg, Germany

[www. baumueller.de](http://www.baumueller.de)

## Table of contents

<b>1</b>	<b>General safety instructions</b> .....	<b>4</b>
1.1	Safety.....	4
1.2	Designated purpose.....	5
1.3	Prohibition of unauthorized modifications and changes.....	6
<b>2</b>	<b>Operating conditions</b> .....	<b>6</b>
2.1	Product description.....	6
2.2	Items supplied.....	6
2.3	Nameplate.....	7
2.4	Technical data.....	8
2.5	Transport, intermediate storage.....	9
2.6	Installation conditions, cooling details.....	10
2.7	Balancing, output elements, vibration.....	11
<b>3</b>	<b>Mounting</b> .....	<b>13</b>
3.1	Safety instructions.....	13
3.2	Installation, fixing.....	13
<b>4</b>	<b>Electrical connections</b> .....	<b>14</b>
<b>5</b>	<b>Commissioning, operation</b> .....	<b>15</b>
5.1	Safety instructions.....	15
5.2	Checks prior to commissioning.....	16
5.3	Commissioning, operation.....	16
5.4	Malfunctions in operation.....	17
<b>6</b>	<b>Inspection and maintenance</b> .....	<b>18</b>
6.1	Inspection.....	18
6.2	Maintenance.....	19
<b>7</b>	<b>Disposal</b> .....	<b>19</b>
<b>8</b>	<b>Annex 1: pole assignment (main connection and control port)</b> .....	<b>20</b>
8.1	Main connection via plug.....	20
8.2	Main connection via the terminal box (Standard design acc. to catalogue).....	20
8.3	Main connection via the terminal box (customer specific design acc. to EN 60034; non UL-approved).....	21
8.4	Main and control connection via combination-mounting-box (customer specific design).....	22
8.5	Fan connection.....	23
8.6	Control port: Resolver.....	23
8.7	Control port: SRS / SRM 50.....	24
8.8	Control port: SEK / SEL 52.....	24
8.9	Control port: ECN 1313 / EQN 1325.....	25
8.10	Control port: ECN 1325 / EQN 1337 (M23) (encoder with EnDat 2.2-port from Heidenhain companies).....	25
<b>9</b>	<b>Appendix 2: water-cooled machines</b> .....	<b>26</b>
9.1	Definitions of power ratings for water-cooled machines.....	26
9.2	Motorcooling.....	26
9.3	Instructions for installation.....	27
9.4	Electrical connections.....	27
9.5	Specifications for required coolant volume flows.....	27
9.6	Coolant consistency.....	28
9.7	Min. coolant temperature against ambient temperature and humidity.....	28
9.8	Malfunctions in operation.....	30
9.9	Inspection.....	30

# 1 General safety instructions

## 1.1 Safety

This electric motor has been constructed in accordance with the relevant safety standards and underwent an operational safety check before leaving our factory.

To ensure correct commissioning and safe utilization, please read the following:

- These Commissioning and Maintenance Instructions and if applicable the enclosed supplementary parts
- The enclosed safety and commissioning notes
- The technical documentation that accompanies the product
- The commissioning and safety notes provided by the manufacturer of the converter
- The national, local, and system-specific regulations concerning your finished product
- The technical instruction of TAM 00697 during the use in safety relevant applications

We draw your attention to the following hazards when using the product:

- Hazards resulting from
- Lifting and transport
  - Electrical power
  - Moving parts
  - Hot surfaces
  - EMC interference
  - Mechanical overload
  - Thermal overload

To avoid damage to persons and property and to minimize residual risks, please read all of the safety instructions and, in particular, those that are marked with a symbol.



### **Risk of fatality due to electric shock**

Failure to observe can lead to fatal or serious injuries.



### **Warning about general dangers**

Failure to observe can lead to serious injury or damage to property.



### **Warning about a dangerous situation**

Failure to observe can lead to damage to the system or peripheral equipment.



### **Touching prohibited**

Failure to observe can lead to serious injury.



### **Improper handling prohibited**

Failure to observe can lead to serious injury.



### **Warning about a hot surface**

Failure to observe can lead to serious injury.



### **Electrostatically sensitive components**

Failure to observe can lead to damage to the system or peripheral equipment.

## 1.2 Designated purpose

The electric motor must only be used for its designated purpose. In this context, the electric motor must only be used for the applications described in the technical documentation under strict observance of all the notes in these Commissioning and Maintenance Instructions.

All assembly, commissioning, maintenance, and operating tasks must be carried out by qualified personnel only.

Within the context of these safety instructions, qualified personnel refers to persons who are trained and authorized in the specialized area, who are authorized to set up, assemble, commission, and operate units, systems, and circuits under application of the applicable safety standards (EN 50110-1).

Inappropriate conduct can result in serious **injury** and **damage to property**.

The **electric motor** is designed for **use** in **industrial applications** and is subject to a number of **standards** and **directives**, including the following:

### Standards

EN 60034-1, EN 60034-5, EN 60034-6, EN 60034-7, EN 60034-9, EN 60034-11, EN 60034-14  
EN 60204-1

### Voltage Directive EC

The electric motors in this series fully comply with the requirements of the Low Voltage Directive EC (conformity).

### EMC Directive EC

The operation of the electric motor in accordance with its designated use must comply with the safety requirements in the EMC Directive EC. The proper installation (e. g. separation of signal lines and power cables, screened lines and cables etc.) is the responsibility of the erector of the installation and the system provider. During converter operation the EMC information of the converter-, encoder- and brake-manufacturer must be observed.

**All national, local, and system-specific regulations must also be observed!**

The electric motor is designed for the following **ambient conditions**:

- Ambient temperature: 0 °C to +40 °C
- Altitude: ≤ 1000 m above sea level
- Relative humidity: 5 % to 85 %

Please take note of any deviating details specified on the nameplate or in the technical documentation. The conditions at the place of utilization must correspond to the details on the rating plate.



Utilization in areas with potentially explosive atmospheres is **prohibited** unless the unit is expressly designed for this purpose (refer to additional notes). Furthermore, the area surrounding the electric motor must be free of inflammable gas mixtures and hazardous concentrations of dust.

Live and hot motor parts are inflammable and may cause serious injury and damage to property.

If, in special cases (for utilization in non-industrial applications), more stringent requirements are in place, e. g., protection against contact with a child's fingers, these conditions must be met by the customer when installing the system.

### Motor design with rare-earth magnets:

	<p>Please be aware of the following risks in the vicinity of a retracted or exposed rotor with a strong magnetic field:</p> <ul style="list-style-type: none"><li>• People with electronic or metallic implants (e. g. cardiac pacemakers, hearing aids, plates or pins) are at risk, if the distance between the implant and the magnetic pole is less than 0.5 m.</li><li>• Due to the strong attraction forces exerted on ferromagnetic parts there is a risk of:<ul style="list-style-type: none"><li>○ Crushing injuries</li><li>○ Damage to measuring and assembly tools, credit cards, watches etc.</li><li>○ Contamination of the rotor assembly due to attracting metal debris or powder.</li></ul></li></ul>
-----------------------------------------------------------------------------------	------------------------------------------------------------------------------------------------------------------------------------------------------------------------------------------------------------------------------------------------------------------------------------------------------------------------------------------------------------------------------------------------------------------------------------------------------------------------------------------------------------------------------------------------------------------------------------------------------------------------------------------------------------------------------------------------------------------------

### Thermal hazard:

	<p>Caution, risk of burns!</p> <p>The <b>surface temperatures</b> on the motors may <b>70° C</b>. If necessary, fit guards!</p> <p>Temperature-sensitive parts, e.g., normal cables or electronic components, must not be placed on or fixed to the hot surfaces.</p> <p>Thermal overloading can destroy the winding and the bearing and lead to the demagnetization of the rare-earth magnets. A thermal sensor should be used to monitor the temperature.</p>
-----------------------------------------------------------------------------------	-----------------------------------------------------------------------------------------------------------------------------------------------------------------------------------------------------------------------------------------------------------------------------------------------------------------------------------------------------------------------------------------------------------------------------------------------------------------

### 1.3 Prohibition of unauthorized modifications and changes



For safety reasons, unauthorized modifications and changes to the electric motor are not permitted. If such modifications/changes are necessary, please contact the motor manufacturer.

No safety devices may be dismantled or decommissioned when operating the electric motor.

## 2 Operating conditions

### 2.1 Product description

With its new DSC 45-100 series, Baumüller is making the torque motor servo-ready.

In developing this series, the focus was on improving ratings in order to achieve a higher torque density while also drastically reducing the volume of the unit. The typical servo speed range of up to 4,000 rpm is, however, still covered. The new DSCs are up to 30 % more compact than conventional servo motors.

The motors of the DSC 45-100 series feature a smooth housing surface to protect against soiling. These motors are particularly easy to mount and offer a high protection type.

### 2.2 Items supplied

The delivery is put together on an order-specific basis.

- The carrier must be notified immediately of any damage caused during transport.
- On delivery, please check that the ratings and type of the motor supplied correspond with the order data. In the event of apparent defects or incomplete delivery, the appropriate Baumüller office or the Baumüller head office in Nuremberg should be notified immediately.

In both of the above cases, commissioning must not take place until the error has been rectified by a specialist.

## 2.3 Nameplate

The nameplate is used to identify each electric motor. The unique motor number is clearly shown on each nameplate and is essential for internal tracking procedures. It must be possible to read the nameplate at all times. Never remove the nameplate from your motor.

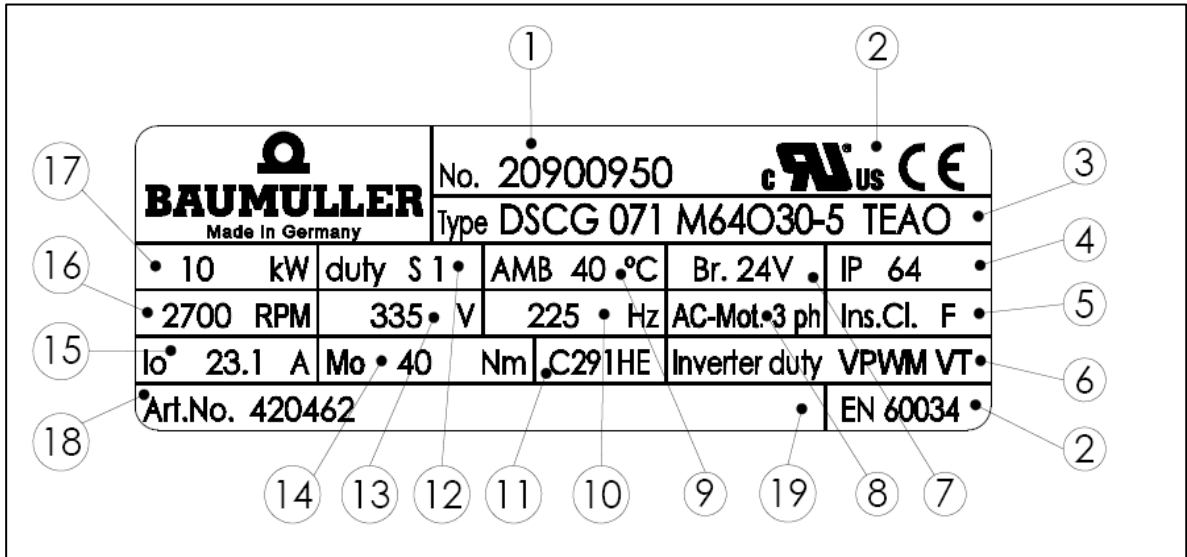

Figure 1: Nameplate

- |                                                |                                                                 |
|------------------------------------------------|-----------------------------------------------------------------|
| 1 → Motor number                               | 10 → Rated frequency                                            |
| 2 → Standards and approbation                  | 11 → Isolation system UL                                        |
| 3 → Motor type / designation                   | 12 → Motor operating type                                       |
| 4 → Motor protection class                     | 13 → Rated voltage $U_N$                                        |
| 5 → Heat category (class of insulation VDE)    | 14 → Standstill torque $M_o$                                    |
| 6 → Motor is powered with converter            | 15 → Standstill current $I_o$                                   |
| 7 → (optional) Supply voltage of the brakes DC | 16 → Rated speed $n_N$                                          |
| 8 → Motor type: 3-phase motor                  | 17 → Rated output $P_N$                                         |
| 9 → Permitted ambient temperature              | 18 → Article number                                             |
|                                                | 19 → Kind of balancing ( <b>only for motor size 45 and 56</b> ) |

## 2.4 Technical data

Built class (EN 60034-7)	IM B5 installation position horizontal IM V1 installation position vertical, shaft end downwards IM V3 installation position vertical, shaft end upwards
<b>Note:</b> On installation positions IM V3 in connection with protective class IP 64, the shaft gland must be protected against ingress of water and dirt.	
Safety class (EN 60034-5)	<b>with consideration of the shaft gland</b> IP 64 Standard: without shaft seal ring IP 65 Option: with shaft seal ring <b>without the consideration of the shaft gland</b> IP 67 for self-cooling versions (IC 410 and IC3W7); not for motors with terminal box IP 65 for surface cooled versions (IC 416) IP 65 for model with terminal box
<b>Caution:</b> The listed safety classes are only met when the plug connection is completely installed (main and control connection) and fully closed terminal box.	
Cooling process (EN 60034-6)	IC 410 Standard: completely enclosed motor design self-cooling <b>without fan</b> IC 416 Option: from shaft height 56 completely enclosed motor surface cooled <b>with fan</b> air flow direction from NDE to DE  IC 3W7 Option from shaft height 71 completely enclosed motor water cooled Cooling circuit connections towards NDE (non-drive end)
Electrical connections ( <b>refer to annex1</b> ) via angled (3 x 90°) rotating built-in boxes	
<b>Caution:</b> In the event of idling currents $I_0 > 36$ A the mains connection is via terminal boxes	
Main connection	8-pole standard: U V W + temperature sensor Option: brake
Control connection	12-pole standard: Resolver 12 / 17-pole Option: absolute encoder Option: Encoder + thermal sensor 12-pole Option: Hiperface-port 17-pole Option: Endat 2.1 9-pole Option: Endat 2.2
fan (optional)	6-pole
Thermal motor protection (EN 60034-11)	temperature sensor KTY84 in the stator winding
Winding insulation (EN 60034-1)	Heat category F ( $\Delta\theta = 105$ K)
Ambient temperature	0 °C... +40 °C (standard)
Altitude of site (EN 60034-1)	≤ 1.000 m above sea level (standard)



Rolling-contact bearings with long-term grease lubrication:	Standard: Ball bearing Option (from shaft height 56): Roller bearing (DE-side)
Calculated bearing use duration	20.000 h (guide value)
Strength of vibration (EN 60034-14)	standard: level A on request: level B (only for ball bearings)
True running (DIN 42955)	Standard: N on request: R (reduced)
Shake proof (EN 60068-2-6)	radial: 3 g (10 Hz to 100 Hz) axial: 0.5 g (10 Hz to 100 Hz)
Holding brake	Option
Rotation speed list value indicator	Standard: 2-pole resolver (high-quality version upon request) Option: absolute encoder with Hiperface-port Option: absolute encoder with EnDat-port

For further technical data, refer to our technical product list online at: [www.baumueller.com](http://www.baumueller.com) under Download and Technical documentation. If necessary, you can request the corresponding documentation.

**Attention!**

If the electric motor supplied is not a standard type as per the technical list or if special contractual arrangements have been made, there may technical differences to the information contained in these Commissioning and Maintenance Instructions. In this case, request the relevant technical supplements.

**2.5 Transport, intermediate storage**

**Water-cooled motors:**

	<p>To avoid frost damage it must be ensured that there is no coolant in the motor during the transport or intermediate storage at ambient temperatures &lt; 3 °C.</p>
-------------------------------------------------------------------------------------	-----------------------------------------------------------------------------------------------------------------------------------------------------------------------

**Transport:**

	<p>The permitted environmental conditions which affect the motor during the transport must be taken from DIN EN 60721-3-2 (class 2K2/2M1). Contrary to the DIN, a reduced temperature range of – 15 °C to + 60 °C is permitted.</p> <p>Suitable load suspension material must be used, e. g. belt webbing, loop belts, etc. If provided, the lifting lugs on the motor can be used for lifting.</p> <p>The terminal boxes and motor connectors must not be used for securing the motor for transport or as lifting eyes.</p> <p>The regulations of the respective countries must be adhered to during transport. Lifting devices and transport and lifting tackle must comply with the relevant regulations.</p>
-------------------------------------------------------------------------------------	------------------------------------------------------------------------------------------------------------------------------------------------------------------------------------------------------------------------------------------------------------------------------------------------------------------------------------------------------------------------------------------------------------------------------------------------------------------------------------------------------------------------------------------------------------------------------------------------------------------------------------------------------------------------------------------------------------------

For information on weight of the single motors, please refer to the technical documentation that accompanies the product.

The motor shaft and the connection surfaces must be protected against corrosion. The motor may only be transported with a shaft protection cover; damage to the motor shaft must be avoided.

**Bearing safety** (applies only for motors with cylinder roller bearings)

	<p>On motors with cylinder roller bearings, the runner must be blocked at the end of the shaft in order to prevent damage during transit.</p> <p>The transport safety <b>must</b> be reused for further transports.</p> <p>If this lock can no longer be used due to mounting of a drive element, other suitable means must be employed for axial fixing of the rotor for transport</p>
-----------------------------------------------------------------------------------	-----------------------------------------------------------------------------------------------------------------------------------------------------------------------------------------------------------------------------------------------------------------------------------------------------------------------------------------------------------------------------------------

**Intermediate storage:**

If a motor is not to be commissioned immediately after delivery, it should be stored inside a building in a dry, dust-free, and low-vibration room ( $V_{rms} \leq 0.2$  mm/s).

The electric motors should be stored at as uniform a temperature as possible, not outside of the temperature range -15 to +60 °C, for no more than two years. Elevated storage temperatures within the framework of the working temperature accelerate the rate at which seals and bearing grease deteriorate and therefore have a negative impact on the service life even before the unit has been commissioned. Direct exposure to incident solar radiation, UV light and ozone also lead to an ageing of the gaskets and must be avoided!

Please note that the warranty periods commence from the date of delivery. For this reason, we recommend that storage periods be kept to a minimum.

Should nevertheless a longer storage be necessary, the environmental conditions acc. to DIN EN 60721-3-1 (class 1K2/1M1) have to be observed. Contrary to the DIN, an expanded temperature range of - 15 °C to + 60 °C is permitted.

**2.6 Installation conditions, cooling details**

	<p><b>For motors with water-cooling please take Section 9 into account in addition.</b></p>
-------------------------------------------------------------------------------------	---------------------------------------------------------------------------------------------

**Surroundings:**

The motor can be installed in roofed rooms in dusty or damp environment and under normal climatic conditions.

Unless alternative arrangements have been made, the motor is designed by default for the following climatic conditions:

- Ambient temperature 0 °C to 40 °C
- Installation height  $\leq 1000$  m above sea level
- Relative humidity 5 % to 85 %

All other allowed application conditions have to correspond to DIN EN 60721-3-3 (class 3K3/3Z12).

It is absolutely imperative to comply with these climatic conditions when installing the unit.

Aggressive, corrosive, abrasive and plastic-dissolving solutions should be kept well away from the motor and the air that is used to cool it.

Consultation with the motor manufacturer is essential in the case of installation outdoors.

### Air cooling:

Please also see **Section 2.4** and the technical documentation that accompanies the product.

Cooling method IC 410 – Self-cooling **without** a fan.

Cooling method IC 416 – Surface cooling **with** a fan.

The following must be observed:

- The installation conditions must not impair thermal convection and radiation.
- The cooling air used for forced ventilation must be able to flow in freely and the hot air must be able to flow out freely. The hot exhaust air must not be sucked back in.
- A clearance of at least 100 mm must be observed in relation to neighboring machine parts.
- If installed in very dirty locations, the housing surface and airways must be cleaned regularly.

### flange connection:

By connecting the motor to the mounting surface, a part of the motor loss performance is lead away via the flange.

The dimensions of the mounting surface based on their axis height are listed in the following table 1. This information provides minimum values for the safe heat dissipation via the motor flange surfaces.

Axis height	Steel plate, width x height x thickness in mm	Mounting surface in m <sup>2</sup>
45	250 x 250 x 10	0.06
56 – 100	450 x 400 x 30	0.18

*Table 1: Mounting surfaces*

The heat dissipation conditions approve on larger mounting surfaces. An insulated mounting of the motors is not permitted.

## 2.7 Balancing, output elements, vibration

	<p>Do not subject the shaft or bearings to impacts.</p> <p>On mounting and dismounting output elements, it is not permitted for any axial forces to be applied to the motor.</p> <p>The generally applicable measures for the protection of output elements against physical contact are to be followed.</p> <p>If a motor without output elements is commissioned, measures must be put in place to ensure the key is not flung out.</p>
-------------------------------------------------------------------------------------	-------------------------------------------------------------------------------------------------------------------------------------------------------------------------------------------------------------------------------------------------------------------------------------------------------------------------------------------------------------------------------------------------------------------------------------------

### Balancing

On an ideal design with fitted key, the runners are dynamically balanced with half fitted keys. (acc. to EN 60034-14 / ISO 8821 / ISO 1940)

**NOTE:** Observe the type of balancing as identified on the shaft end face and on the nameplate:

H = Balancing with half key	(standard design)
F = Balancing with full key	(special design)
N = Balancing without key	(special design)

### Output elements:

On mounting the output element, pay attention to the related type of balancing. The output elements must themselves be balanced in accordance with ISO 1940.

Suitable jigs are always to be used for fitting or removing output elements (e.g., clutch disk, gear, pulley).

- Use the threaded hole in the end of the shaft.
- When pulling, use intermediate washers to provide the shaft with mechanical protection.
- When hoisting heat up the drive elements if required (max. permissible temperature at shaft end 150°C).

### Attention!

- On shaft versions without a key, the output elements are to be fastened to the output shaft **with the aid of suitable clamping sets**.
- On shaft versions with a key, it must be ensured that **the output elements rest on the shaft shoulder**. Note: The chamfer or radius on the output element and the shaft radius on the shoulder must be matched.
- Is the tapped hole in the end of the shaft used for axial securing of output elements (e. g. belt pulley), the maximum tightening torque acc. to following table 2 must not be exceeded.

thread	tightening torque in Nm
M5	2,2
M8	10,0
M10	19,0
M12	33,0

Table 2: Tightening torque for safety screw S of a belt pulley

**appropriate measures for securing screw must be applied**

### Vibration:

	<p>The site vibration response of the system, which is determined by the output elements, the mounting conditions, the alignment, the installation, and the effects of external vibrations, may cause the vibration values at the motor to increase.</p> <p>In the interest of reliable motor operation and a long bearing service life, the permitted vibration values in accordance with EN 60034-14 should not be exceeded. Under certain circumstances, the rotor may need to be fully balanced with the output element (in accordance with ISO 1940).</p> <p>The vibration value after assembly must not exceed the permitted rates of acceleration (see <b>Sect. 2.4</b> Technical data).</p> <p>In case of deviations from the normal operation - e. g. increased temperatures, noise, vibration - disable the motor. Identify the cause and, if necessary, contact the manufacturer.</p>
-------------------------------------------------------------------------------------	--------------------------------------------------------------------------------------------------------------------------------------------------------------------------------------------------------------------------------------------------------------------------------------------------------------------------------------------------------------------------------------------------------------------------------------------------------------------------------------------------------------------------------------------------------------------------------------------------------------------------------------------------------------------------------------------------------------------------------------------------------------------------------------------------------------------------------------------------------------------------------------------------

### 3 Mounting

#### 3.1 Safety instructions

##### Before mounting:

	<p>Never mount or commission a damaged electric motor. Never install the electric motor in a damaged machine. Before mounting the electric motor, make sure it is suitable for your machine.</p>
-----------------------------------------------------------------------------------	----------------------------------------------------------------------------------------------------------------------------------------------------------------------------------------------------------

##### During mounting:

	<p>Only mount the motor using the fastening features provided. The motor should not be exposed to knocks, e. g., with a hammer, or shocks when mounting. Make sure that all covers and safety devices are mounted. All safety devices must comply with the latest regulations (e g. EN 60204). <b>Air cooling:</b> Protective guards have to be fitted to the air inlets and outlets, if there is a risk of foreign bodies falling into the fan during operation.</p>
-----------------------------------------------------------------------------------	---------------------------------------------------------------------------------------------------------------------------------------------------------------------------------------------------------------------------------------------------------------------------------------------------------------------------------------------------------------------------------------------------------------------------------------------------------------------------------------

#### 3.2 Installation, fixing

##### Prior to and during mounting, check that

- The motor is not damaged (e. g., the shaft sealing ring must not have sustained any damage at all from sharp or pointed objects).
- The motor is not mounted in the danger zone of other equipment.
- The motor is used for the designated purpose (see **Sect. 1.2, Sect. 2.4**).  
*(Observe nameplate details, warning labels, and signs.)*
- Anti-corrosion agents have been fully removed from the shaft ends.  
*If a common solvent such as acetone or a cleaning solvent is used, it must not be allowed to wet the shaft sealing ring.*
- The motor is designed for the ambient conditions and environmental influences on site (see **Sect 2.4**).
- The compartment in the machine is suitable for the cooling method employed for the electric motor.  
*The motor is to be installed in such a way that heat can be adequately dissipated via the housing surface and via the motor flange surface (refer to **Sect. 2.6**)*
- The motor can be mounted and operated with the fastening features and connection data provided.  
*The mounting dimensions of the motor and the tolerance details are provided in the technical documentation that accompanies the product. When mounting the flanges on the motor, make sure that the flange surface rests well and evenly. The supports and bearing surfaces must be clean and undamaged. They must be precisely aligned with the connecting shafts to prevent the bearings, shafts, and housing being exposed to damaging loads through misalignment throughout the entire system. When tightening the flange fixing screws (**min. property class 8.8**), make sure that the flange connection is not distorted.*
- No liquid can penetrate the upper bearing when installing vertically with the shaft end facing upwards.
- The permitted radial forces according to the operating characteristics in the technical documentation that accompanies the product are not exceeded (if necessary, contact Baumüller for clarification).  
*The motor manufacturer must always be contacted if axial forces occur.*
- The brake (optional) can be ventilated after the operational voltage has been applied (audible operating noise).

- The rotor rotates smoothly without a scraping sound.  
*On motors with a brake fitted, release the brake beforehand.*
- the design of the motor and encoder cables – and of the fan cable (if available), complies with the details in the technical documentation that accompanies the product.
- The output and input elements are secured.
- the complete cooling circuit is leak proof and fully functional and protected against any foreign objects falling into it.



## 4 Electrical connections

### Important notes:

	<p>All work must be carried out by specially trained personnel.</p> <p>Work must only be carried out when the system has been de-energized and secured against unintentional restarting (including auxiliary circuits).</p> <p>Work must only be carried out once the motor has come to a standstill. <i>In the case of three-phase synchronous motors with permanent-magnet excitation, a voltage of &gt; 60 V can occur at the motor contacts when the rotor is turning.</i></p> <p>Regulations for working in electrical plants must be observed!</p>
-----------------------------------------------------------------------------------	--------------------------------------------------------------------------------------------------------------------------------------------------------------------------------------------------------------------------------------------------------------------------------------------------------------------------------------------------------------------------------------------------------------------------------------------------------------------------------------------------------------------------------------------------------------

**Attention!** The safety regulations for work in electrotechnical systems must be observed according to EN 50110-1:

- Isolate
- Secure against unintentional restarting
- Verify safe isolation from the supply
- Earth and short
- Safeguard or cover adjacent live parts

	<p>The electric motor must be operated via a correspondingly designed converter. A direct connection to the three-phase mains can destroy the motor.</p> <p>Ensure that the phase sequence and the pin assignment are correct!</p> <p>Electrical connections, protective conductor connections, and screen connections (when using screened cables) must be permanently secure!</p>
	<p>Never touch the contacts of the encoder or thermal sensors with your hands or with tools that are electrostatically charged. The encoder and the thermal sensors are electrostatically sensitive components.</p>

### Electrical installation:

- The person setting up the system is responsible for correct electrical installation.
- The motor data on the nameplate must be observed.
- Connection cables and connectors must be correctly rated for the voltages and currents and must be suitable for the method of installation employed.
- The motor and its modules (brake, encoder, fan, etc.) must be connected in accordance with the details in the wiring diagrams (see **enclosed wiring diagrams** and **Section 8**).
- Screened power and encoder cables must be used to protect against electromagnetic EMC interference from motor cables and their effects on the encoder and control systems. Please refer to the EMC notes provided by the supplier of the converter.
- In the interest of ensuring operational safety, we recommend that you use connecting cables assembled by Baumüller (see Technical Product List).
- Before connection, the plugs, sockets and the terminal boxes must be checked for damage, corrosion, dirt and dampness.

- In order to ensure the appropriate type of protection is provided, make sure that the screwed connections, gaskets, and sealing surfaces of the connectors are seated correctly and are tight.  
**Note!** Also, to maintain the safety class, the rotating connecting boxes should not be modified by more than 5 times in the connecting direction by turning.
- Connectors must not be exposed to mechanical stress. If necessary, provide strain, shearing, twist, and anti-kink relief

**In case of connection using a terminal box it is to be ensured**

- the insulation is not over stripped, i. e. that the insulation extends right up to the cable lugs or terminals. The ends of the cables must not protrude.
- the cable lugs that are used are suitable for the dimensions and cross-sections of the terminals and cables.
- the screwed electrical connections are tightened in accordance with the specified tightening torque (comp. **Section 8.3 table 5**).
- the protection type is maintained.  
**Note:** All lead-ins that are not used must be closed off with the sealing caps. The sealing elements must be fully functional and undamaged when closing the terminal box.



**5 Commissioning, operation**

**5.1 Safety instructions**

**Working on the electric motor:**

	<p>Work must not be carried out on the electric motor until the motor has come to a standstill, is electrically isolated, and has cooled down. All connections, such as screw connections, that were loosened when working on the motor must be tightened again prior to commissioning.</p> <p>When carrying out work on the motor, please observe the technical instructions and notes in the respective sections in these Commissioning and Maintenance Instructions.</p> <p><b>Attention:</b> if the optional holding brake is fitted, this brake must not perform a safety function during work on the motor (e. g., retaining loads)!</p>
-------------------------------------------------------------------------------------	------------------------------------------------------------------------------------------------------------------------------------------------------------------------------------------------------------------------------------------------------------------------------------------------------------------------------------------------------------------------------------------------------------------------------------------------------------------------------------------------------------------------------------------------------------------------------------------------------------------------------------------------



**Risk of fatality due to electric shock:**

	<p>Make sure that the motor is disconnected and electrically isolated.</p> <p>Never disconnect the motor connections during operation.</p> <p>Only connect measuring instruments when the motor is disconnected from the power supply and electrically isolated.</p>
	<p>Only commence work on the motor connections when you are sure the motor is electrically isolated and there is no potential.</p> <p>When in operation, electric potential can be found at the motor contacts and at the motor windings. Never touch these modules/elements while the motor is in operation.</p>

**Installing and uninstalling safety devices:**

	<p>The electric motor must not be operated without installed safety devices.</p> <p>The motor must be put out of operation when installing and dismantling components and systems which are provided for monitoring the motor for safe operation</p>
-------------------------------------------------------------------------------------	------------------------------------------------------------------------------------------------------------------------------------------------------------------------------------------------------------------------------------------------------

### Danger on physical contact:

	Make sure that the electric motor has come to a standstill and is secured against unintentional restarting before you touch it.
	Only touch the output shaft when it is electrically isolated and the motor has come to a standstill. Otherwise there is a risk due to the rotating rotor. <b>Danger of burns!</b> Never touch the motor housing when the motor is running at rated load. The surface temperatures on the motors may exceed <b>70 °C</b>

## 5.2 Checks prior to commissioning

- The drive is undamaged and is not located within the danger zone of other equipment.
- The motor is correctly aligned and fastened. All screwed connections are correctly tightened.
- All the appropriate safety devices (mechanical, thermal, and electrical) are mounted.
- The motor connections have been made correctly.
- The cables are not in contact with the surface of the motor.
- The protective conductor system is correct and its functionality has been checked.
- The drive is not blocked (release brake, if present).
- Emergency stop functions have been checked.
- Fan is connected properly and its function has been checked.

## 5.3 Commissioning, operation

### Note on brake function (if present):

	The brake is designed as a holding brake with an emergency stop function. (power failure, emergency stop) It must not be used as a working brake.
-------------------------------------------------------------------------------------	---------------------------------------------------------------------------------------------------------------------------------------------------------

Commissioning must be carried out exclusively by qualified personnel.

Please refer to the commissioning instructions for the converter.

### Checks during commissioning:

- Release the brake, if necessary.
- Has the functionality of all motor modules such as the brake, encoder, fan, etc., been checked and are the conditions of use met?
- Have all electrical connections been made correctly and tightened (**observe wiring diagrams, see Section 8 and respectively the enclosed wiring diagrams**)?
- Have all protection measures that eliminate the possibility of contact with live parts, hot surfaces, and rotating and moving parts and modules been observed and are these measures fully functional?
- Have all output elements been mounted and adjusted in accordance with the manufacturer's instructions?
- Are measures in place to ensure that the maximum permitted speed  $n_{max}$  of the motor cannot be exceeded? The maximum permitted speed  $n_{max}$  is the highest permitted operating speed for short-time duty.

### Checks during operation:



- Listen out for unusual noises.
- If scraping, scratching, grinding, or other similar noises occur, stop the drive immediately and locate the cause.



- Check the motor surface and connection cables for dirt, e. g., layers of dust, oil deposits, dampness, etc.
- Check the maintenance intervals.
- Check air inlet and outlet ports for fouling.

## 5.4 Malfunctions in operation

### Safety instructions:

	Troubleshooting and rectification must only be performed by qualified personnel. Do not disconnect any of the safety devices – even during test runs.
	Only disconnect and connect connection cables when they are electrically isolated and secured. Observe the 5 safety rules for "Isolation" (see <b>Sect. 4</b> ).
	Beware of hot surfaces!

In case of malfunctions in operation always

- Refer to the operating instructions for the machine/system.
- Refer to the operating instructions for the converter.
- If necessary, contact the manufacturer of the motor or converter.

### Have the following information ready:

- nameplate data
- type and scope of malfunction
- circumstances leading up to the malfunction
- application data (torque cycle, speed and forces over time; ambient conditions)

The following selection of possible causes can be helpful in the fault rectification process:

Malfunction	Cause	Remedy
Motor does not start	No controller enable Controller fault, encoder fault  Brake does not release  Faulty brake  No power supply  Rotating field	Activate controller enable Read out fault list at converter or controller; rectify fault  Check control, connections, and power supply  Repairs carried out by manufacturer  Check connections and power supply  Check phase sequence. If necessary, replace the connection cables
Uneven running	Insufficient screening on connecting cables Controller parameters too high	Check screening connection and grounding Optimize controller parameters

Malfunction	Cause	Remedy
Vibrations	Coupling element or driven machine poorly balanced Inadequate alignment of the drive train Fixing screws loose	Rebalance Realign machine set Check and tighten screwed connections
Running noises	Foreign matter in motor Damaged bearing	Repairs carried out by motor manufacturer Repairs carried out by motor manufacturer
Temperature rise in the motor Motor temperature monitoring unit trips	Drive overload Motor surface/air ducts soiled Cramped installation conditions Brake does not release sufficiently: grinding brake	Check motor load and compare with nameplate Clean motor surface/air ducts Check motor has been mounted in accordance with <b>Sect. 2.6</b> and <b>3</b> Repairs carried out by motor manufacturer
Current consumption too high, motor torque too low	Indexing angle incorrect	Check indexing angle and adjust if necessary

Table 3: Malfunctions

## 6 Inspection and maintenance

### Working on the electric motor:

	<p>Work must not be carried out on the electric motor until the motor has come to a standstill, is electrically isolated, and has cooled down. All connections, such as screw connections, that were loosened when working on the motor must be tightened again after the inspection and maintenance work.</p> <p>When carrying out work on the motor, please observe the technical instructions and notes in the respective sections in these Commissioning and Maintenance Instructions.</p> <p>When carrying out maintenance work, observe all safety instructions which also apply to the commissioning of the motor (see <b>Sect. 5.1</b>).</p> <p><b>Attention:</b> if the optional holding brake is fitted, this brake must not perform a safety function during work on the motor (e. g. retaining loads)!</p>
-------------------------------------------------------------------------------------	------------------------------------------------------------------------------------------------------------------------------------------------------------------------------------------------------------------------------------------------------------------------------------------------------------------------------------------------------------------------------------------------------------------------------------------------------------------------------------------------------------------------------------------------------------------------------------------------------------------------------------------------------------------------------------------------------------------------------------------------------------------------------------------------------------------------

### 6.1 Inspection

Depending on the severity of soiling on site, cleaning will have to be carried out regularly to guarantee the continuous adequate dissipation of heat.

If an optional brake is fitted, wear limits are specified (e. g., maximum permissible operating air gap, maximum number of emergency braking operations). The actual degree of wear on the brake must be checked at regular intervals. If the permissible wear limits are reached, the brake must be replaced (see **Sect. 6.2**).

If an optional shaft sealing ring is used, it must be checked at regular intervals to ensure it is functioning correctly (leakage).

## 6.2 Maintenance

The service life of the bearings and sealing elements can differ greatly depending on the operating conditions (e.g., operating mode, temperature, speed, and load).

In the case of trouble-free operation, we generally recommend the following maintenance procedures:

- Replacement of the **bearings** after 20.000 running hours (the bearings are designed for a calculated service life of 20.000 running hours)
- Replacement of the **shaft sealing ring** after approximately 5.000 running hours, if present and if no leaks have been detected during previous inspections

If an optional **brake** is fitted, it is essential that it is replaced when its wear limits are reached.

Maintenance work must be carried out by Baumüller or a specialist company commissioned by Baumüller.

### Caution!

**It is imperative, on motors that are used for safety related applications, to heed the technical instructions of TAM 00697 during service and maintenance work.**

## 7 Disposal

The motor must be disposed of in accordance with the relevant national and local regulations within the framework of the normal recycling process.

The encoder electronics (if provided) must be disposed of in the proper manner as electronic scrap.

## 8 Annex 1: pole assignment (main connection and control port)

### 8.1 Main connection via plug

The standstill current  $I_0$  of the motor determines the connector size of the built-in box.

Size 1:  $I_0$  to 20 A;

Size 1.5:  $I_0$  to 36 A

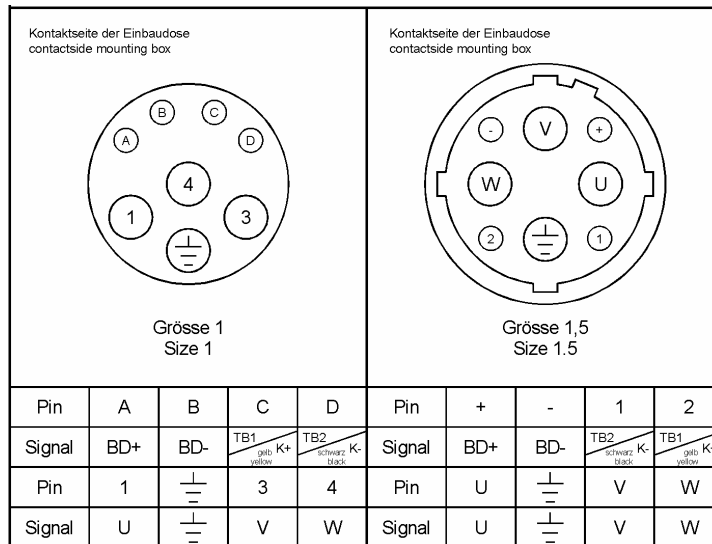

Figure 2: Main connection with thermal sensor and brake

**Note:** If the **thermal sensor** is routed via the encoder channel, signals **K+** and **K-** are omitted from the wiring diagrams above.

### 8.2 Main connection via the terminal box (Standard design acc. to catalogue)

Use during standstill current  $I_0 > 36$  A.

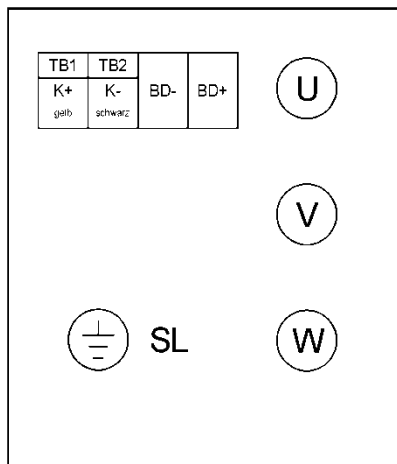

Figure 3: pole assignment with thermal sensor and brake

**Table 4** shows the cable leads of the terminal boxes and the main connector pin assignment together with the permissible torque specification.

On the connections for the cable leads we recommend the use of EMC connectors.

When tightening the terminal screws, it is recommended to hold against the conductor, to keep the terminal board free from torsion forces.

Terminal box size	Cable leads	Number of main connection terminals	Torques for terminals in Nm
□ 156	1 x M40 + 1 x M25	3 x M6	3.0
□ 196	1 x M50 + 1 x M25	3 x M8	6.0

Table 4: Terminal box versions

### 8.3 Main connection via the terminal box (customer specific design acc. to EN 60034; non UL-approved)

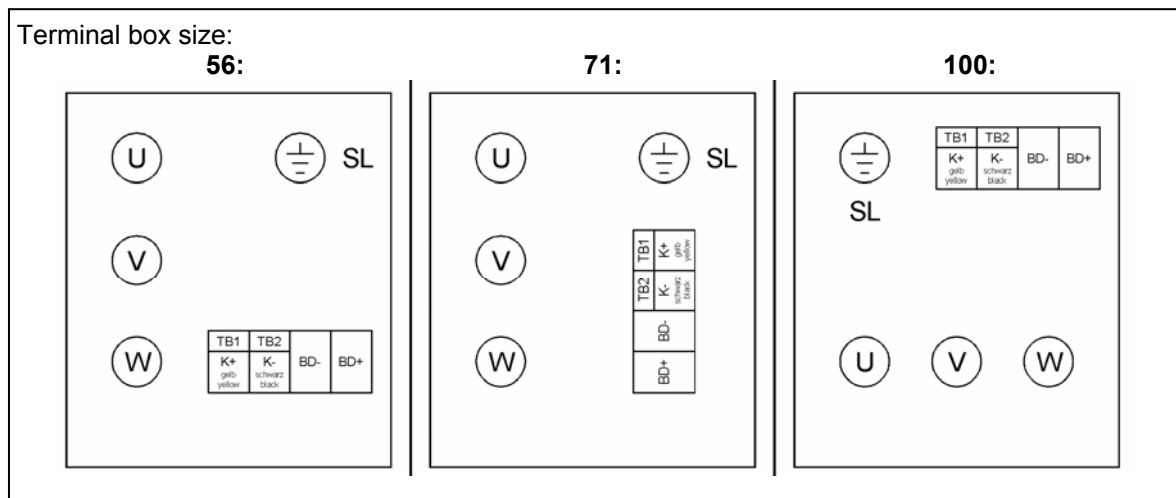

Figure 4: pole assignment special variant

**Table 5** shows the cable leads of the terminal boxes and the main connector pin assignment together with the permissible torque specification.

On the connections for the cable leads we recommend the use of EMC connectors.

When tightening the terminal screws, it is recommended to hold against the conductor, to keep the terminal board free from torsion forces.

Terminal box size	Cable leads	Number of main connection terminals	Torques for terminals in Nm
56	1 x M20 + 1 x M16	3 x M4	1,2
	1 x M25 + 1 x M16	3 x M4	1,2
71	1 x M20 + 1 x M16	3 x M6	3,0
	1 x M25 + 1 x M16	3 x M6	3,0
100	1 x M40 + 1 x M16	3 x M8	6,0

Table 5: Terminal box versions

#### 8.4 Main and control connection via combination-mounting-box (customer specific design)

This combination- mounting-box is generally mounted on the end plate on NDE-side. The box is 90 °angulated and contrary to the standard design of the motors not turnable.

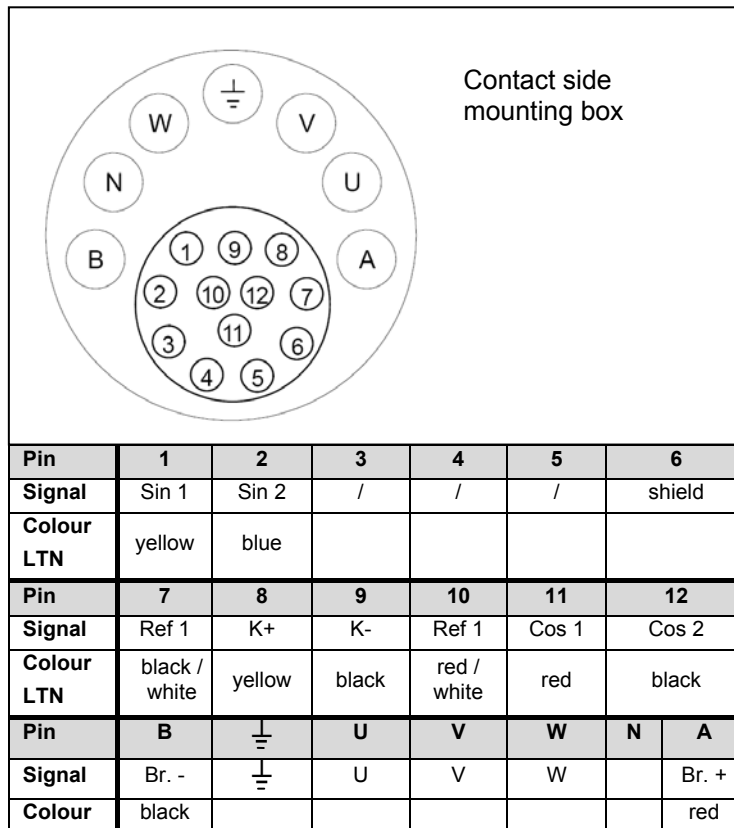

Figure 5: pole assignment of the combination-mounting-box

**Outside section:** Pin „B to A“ shows the pole assignment for the power terminal and PE-brake.

**Inside section:** Pin „1 to 12“ shows the pole assignment for resolver and thermal sensor.

## 8.5 Fan connection

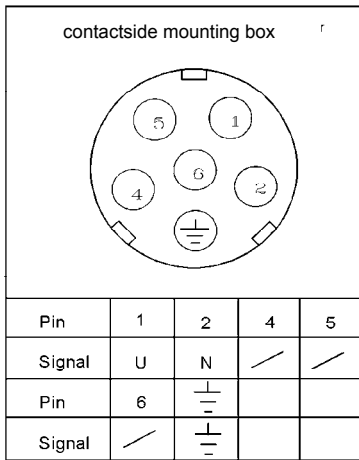

Figure 6: pole assignment of the fan

## 8.6 Control port: Resolver

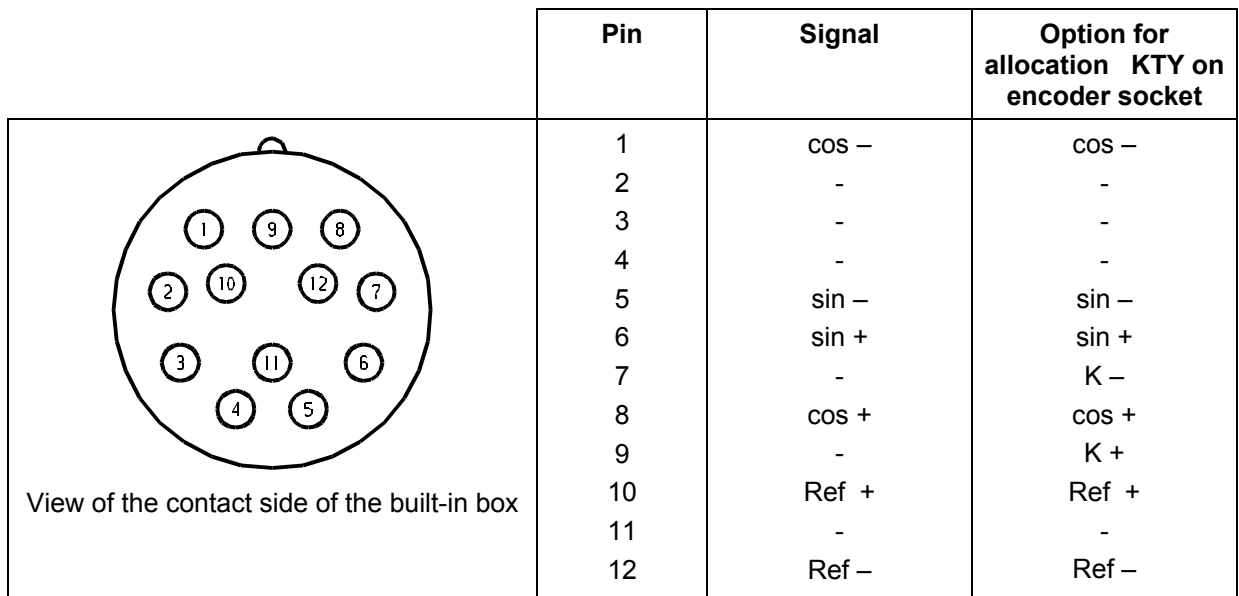

Figure 7: pole assignment resolver

### 8.7 Control port: SRS / SRM 50

(encoder with Hiperface-port from SICK / Stegmann companies)

	Pin	Signal	Option for allocation KTY on encoder socket
 <p>View of the contact side of the built-in box</p>	1	ref cos	ref cos
	2	+ 485	+ 485
	3	-	K +
	4	-	K -
	5	sin	sin
	6	ref sin	ref sin
	7	- 485	- 485
	8	cos	cos
	9	-	-
	10	Gnd	Gnd
	11	-	-
	12	+ U	+ U

Figure 8: pole assignment SRS / SRM 50

### 8.8 Control port: SEK / SEL 52

(encoder with Hiperface-port from SICK / Stegmann companies)

	Pin	Signal	Option for allocation KTY on encoder socket
 <p>View of the contact side of the built-in box</p>	1	ref cos	ref cos
	2	+ 485	+ 485
	3	-	K +
	4	-	K -
	5	sin	sin
	6	ref sin	ref sin
	7	- 485	- 485
	8	cos	cos
	9	-	-
	10	Gnd	Gnd
	11	-	-
	12	+ U	+ U

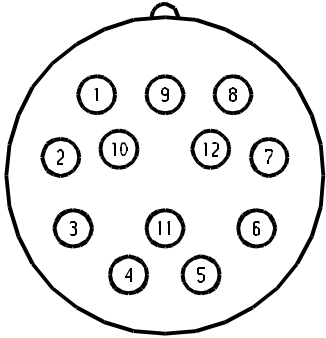
Figure 9: pole assignment SEK/ SEL 52



### 8.9 Control port: ECN 1313 / EQN 1325

(encoder with EnDat 2.1-port from Heidenhain companies)

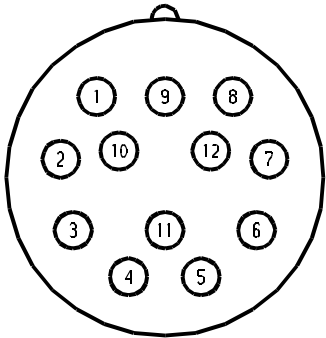
	Pin	Signal	Option for allocation KTY on encoder socket
 <p>View of the contact side of the built-in box</p>	1	U <sub>p</sub>	U <sub>p</sub>
	2	-	-
	3	-	-
	4	0 V	0 V
	5	-	K +
	6	-	K -
	7	U <sub>p</sub>	U <sub>p</sub>
	8	Clock	Clock
	9	Clock inv.	Clock inv.
	10	0 V	0 V
	11	-	-
	12	B +	B +
	13	B -	B -
	14	Data	Data
	15	A +	A +
	16	A -	A -
	17	Data inv.	Data inv.

Figure 10: pole assignment ECN 1313 / EQN 1325

### 8.10 Control port: ECN 1325 / EQN 1337 (M23)

(encoder with EnDat 2.2-port from Heidenhain companies)

	Pin	Signal
 <p>View of the contact side of the built-in box (M23)</p>	1	Clock
	2	Clock inv.
	3	U <sub>p</sub>
	4	0 V
	5	Data
	6	Data inv.
	7	Sensor Up
	8	Sensor 0 V
	9	-

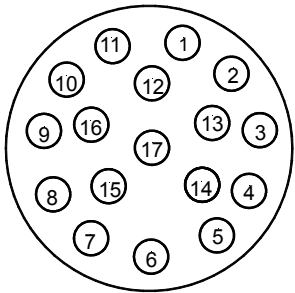
Figure 11: pole assignment ECN 1325 / EQN 1337 (M23)

**Note:**

- For other encoder types and optional lead for the temperature sensor via the encoder cable, see the enclosed wiring diagram or technical documentation for the pin assignment
- The encoder of **Section 8.7** to **8.10** are components susceptible to ESD.

## 9 Appendix 2: water-cooled machines

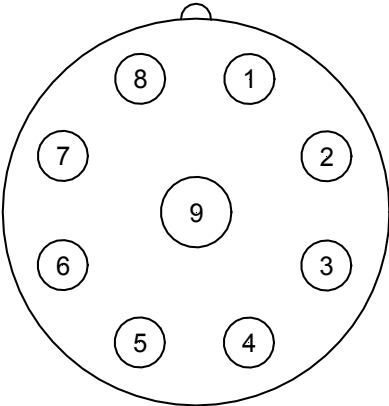
In addition to the previous chapters for water-cooled motors (EN 60034-6; IC 3W7) the following must be considered complementary:

### 9.1 Definitions of power ratings for water-cooled machines

The power ratings (torques) that appear in the list apply to permanent operation S1 at nominal speed, provided the cooling circuit requirements for water-cooled motors are met!

The reduction factors included in the table below must be considered when operating these motors with higher coolant inlet temperatures:

Coolant inlet temperature	25 °C	30 °C	35 °C	40 °C	45 °C
Percentage of list performance (torque)	100 %	97 %	95 %	92 %	89 %

Table 6: Reduction factors

### 9.2 Motorcooling

The cooling system for these water-cooled motors is in stainless steel.

The two water connections (inlet and outlet) on the NDE are supplied as standard with a stainless steel tube Ø8 x 1 without extra termination systems.

The coolant (in accordance with the coolant properties specified in **Section 9.6**) is permitted to contain corrosion inhibitors and anti-bacterial additives. The type and volume of these additives is based on the respective manufacturer's recommendations and the prevailing ambient conditions.

	<p>The safety regulations for the product from the manufacturer of the corrosion inhibitors and anti-bacterial additives must be observed.</p> <p>Cooling lubricants employed in the manufacturing process are not allowed to be used to cool the motor!</p> <p>To prevent blockages and deposits in the coolant pipes and channels, coolants used in closed or open cooling circuits must be filtered. When used in a closed cooling circuit, the coolant must be filtered before it is poured in, in open cooling circuit basically (filter fineness: &lt; 0.1 mm).</p>
-------------------------------------------------------------------------------------	---------------------------------------------------------------------------------------------------------------------------------------------------------------------------------------------------------------------------------------------------------------------------------------------------------------------------------------------------------------------------------------------------------------------------------------------------------------------------------------------------------------------------------------------------------------------------

Note: The system manufacturer is responsible for the planning of the cooling circuit. Condensed water must not be allowed to accumulate.

### 9.3 Instructions for installation

Coolant is supplied and discharged via smooth stainless steel tubes Ø8 x 1 on the NDE of the motors.

A suitable connection to the external cooling circuit can be made for example using John Guest quick connect fittings type SM 040808 S (Ø 8 to Ø 8). Any other connector approved for connecting to smooth stainless steel tubes and capable of withstanding the operating and testing conditions may also be used.

	<p><b>Cooling circuit connection:</b></p> <p>The coolant pipes should not exert compression-tension forces or torsional strain on the motor connections.</p> <p>The connection must be made by specially trained personnel. During this process the motor must be disconnected and electrically isolated.</p> <p>When coupling and uncoupling the coolant pipes, make sure that coolant does not enter the motor's terminal box.</p>
-----------------------------------------------------------------------------------	--------------------------------------------------------------------------------------------------------------------------------------------------------------------------------------------------------------------------------------------------------------------------------------------------------------------------------------------------------------------------------------------------------------------------------------

	<p><b>Leak test acc. to EN 50178:</b></p> <p>The cooling system is to be checked for leaks before commissioning by pressure testing with coolant (water). The test pressure must be twice the operating pressure (minimum test pressure 1 bar). The coolant used does not have to be brought to operating temperature for this purpose. Pressure must be maintained until all areas have been tested for leaks (minimum test duration 10 minutes).</p>
-----------------------------------------------------------------------------------	--------------------------------------------------------------------------------------------------------------------------------------------------------------------------------------------------------------------------------------------------------------------------------------------------------------------------------------------------------------------------------------------------------------------------------------------------------

### 9.4 Electrical connections

The standard power connection for water-cooled motors has to be carried out according to the dimensional drawings of the technical documentation.

### 9.5 Specifications for required coolant volume flows

Motortype	Volume flow in l / min	Pressure decrease ± 15 % in bar	Heating in K	Max. coolant pressure in bar	Connection(2x) in mm
DSC071K64W	5	0,33	3	6	stainless steel tube Ø8 x 1
DSC071S64W	5	0,4	5	6	stainless steel tube Ø8 x 1
DSC071M64W	5	0,5	6	6	stainless steel tube Ø8 x 1
DSC100K64W	5	0,34	3	6	stainless steel tube Ø8 x 1
DSC100S64W	5	0,4	5	6	stainless steel tube Ø8 x 1
DSC100M64W	5	0,46	7	6	stainless steel tube Ø8 x 1

Table 7: coolant volume flows

## 9.6 Coolant consistency

The coolant must satisfy the following specifications:

Conditions	Unit	Value
Maximum permissible system pressure	bar	6
Temperature of coolant- for motor	°C	10 to 25
pH value (at 20 °C)	---	6.5 to 9
Overall hardness	mmol / l	1.43 to 2.5
Chloride - Cl-	mg / l	< 200
Sulfate - SO <sub>4</sub> <sup>2-</sup>	mg / l	< 200
Oil	mg / l	< 1
Permissible particle size of solid foreign objects, particles (e.g., sand)	mm	< 0.1

**Table 8: Coolant consistency**

Clean water that is free of dirt and suspended matter must be used as a coolant.

## 9.7 Min. coolant temperature against ambient temperature and humidity

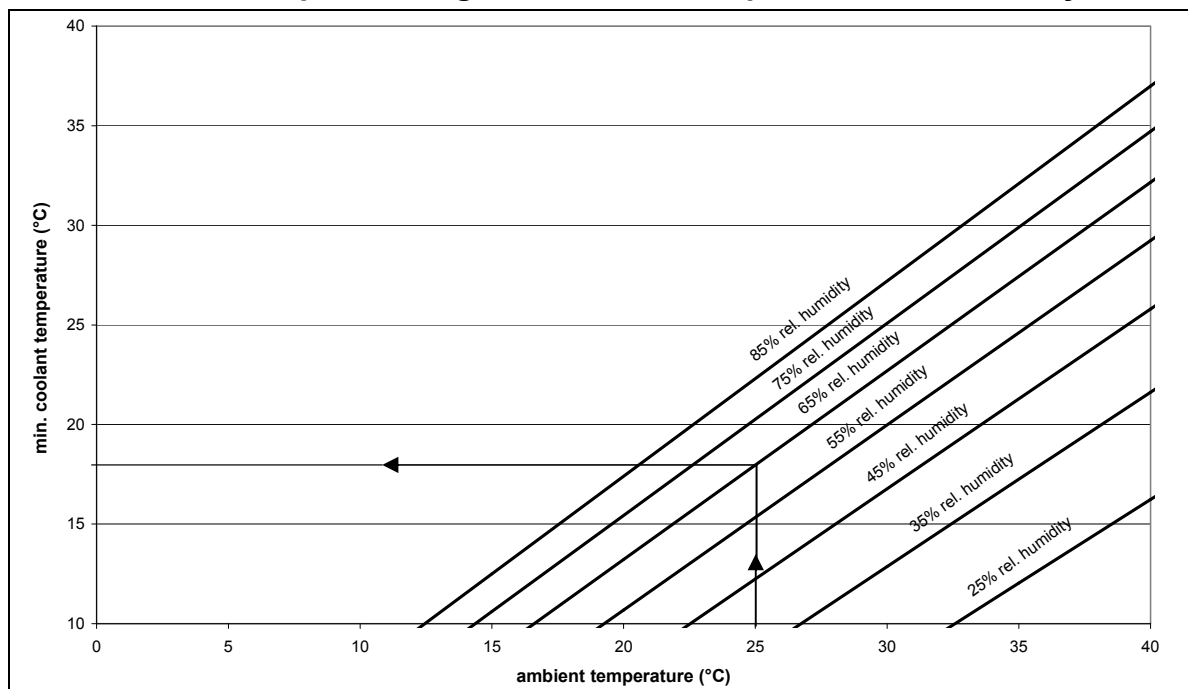

**Figure 12: Determination of the coolant temperature**

The allowed coolant temperature depends on relative humidity and ambient temperature. For example with an ambient temperature of 25 °C and a relative humidity of 65 % the minimum coolant temperature is 18 °C. Because these are limiting values on practical side a coolant temperature greater than 18 °C should be used.

If this minimum coolant temperature will be under run the two- point controller of Baumüller drive must be used to avoid condensation (see **figure 13** on next page).

**Note:**

For standstill of motor for longer time the cooling must be stopped.(to avoid condensation).  
If ambient temperatures of  $< 3\text{ }^{\circ}\text{C}$  may occur during a longer motor standstill, coolant should be discharged as a precaution (to prevent frost damage).

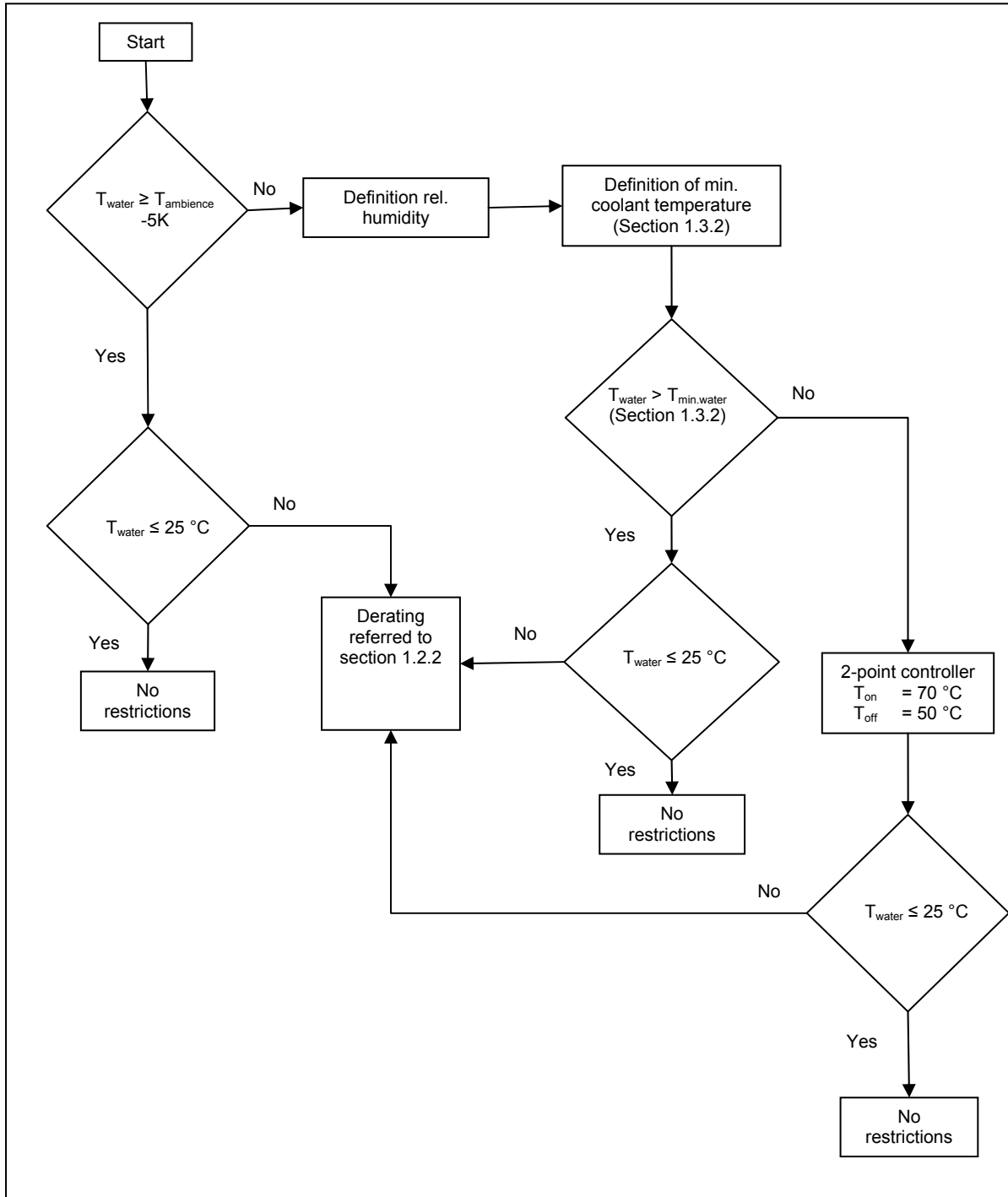

Figure 13: Flow chart coolant temperature

## 9.8 Malfunctions in operation

Malfunction	Cause	Remedy
Temperature rise in the motor Motor temperature monitoring unit trips	Water cooling not active.  Coolant supply inadequate - Deposits in the cooling channels - Faults in the external cooling system	Check and switch on if necessary  Check water circuit - Check, and clean if necessary - Follow plant supplier's instructions
Overpressure in the cooling system	Heavily soiled coolant Cooling channels blocked  Malfunctions in the external cooling system	Filter coolant Check and, if necessary, clean Follow plant supplier's instructions

*Table 9: Malfunctions water cooling*

## 9.9 Inspection

During regular cleaning the flow rate and the pressure ratio of the cooling system must be checked

### *Warranty and liability*

All the details in this documentation are non-binding customer information and subject to ongoing change and will be constantly updated by our editing staff. Warranty and liability claims against Baumüller Nürnberg GmbH are excluded if, in particular, damage is caused by one or more of the following:

- You have not followed the instructions in this documentation.
- You have not used the system for the purpose intended.
- You have
  - mounted, installed, commissioned, operated the system incorrectly or have not carried out the required maintenance
  - permitted the system to be mounted, installed, operated and/or maintained by unqualified or insufficiently qualified personnel,
  - overloaded the system,
  - operated the unit with
    - faulty safety devices,
    - safety devices that were incorrectly fitted or not fitted
    - safety devices or protective devices not in proper working order
  - not operated the system in the stipulated ambient conditions.
- You have modified the system without the written approval of Baumüller Nürnberg GmbH.
- You have not observed the instructions concerning maintenance contained in the component descriptions.
- You have not monitored parts that are subject to wear sufficiently.
- You have performed a repair incorrectly.
- You have combined the system with products from other manufacturers in an improper manner.
- You have combined the drive system with faulty and/or incorrectly documented products from another manufacturer.

The "General sales and delivery conditions" of the respective newest version from Baumüller Nürnberg GmbH apply in principle.

These will be made available to you at the latest on conclusion of the contract.